

REVISIONS				
ZONE	REV	DESCRIPTION	DATE	APPROVED
	A	ORIGINAL RELEASE		

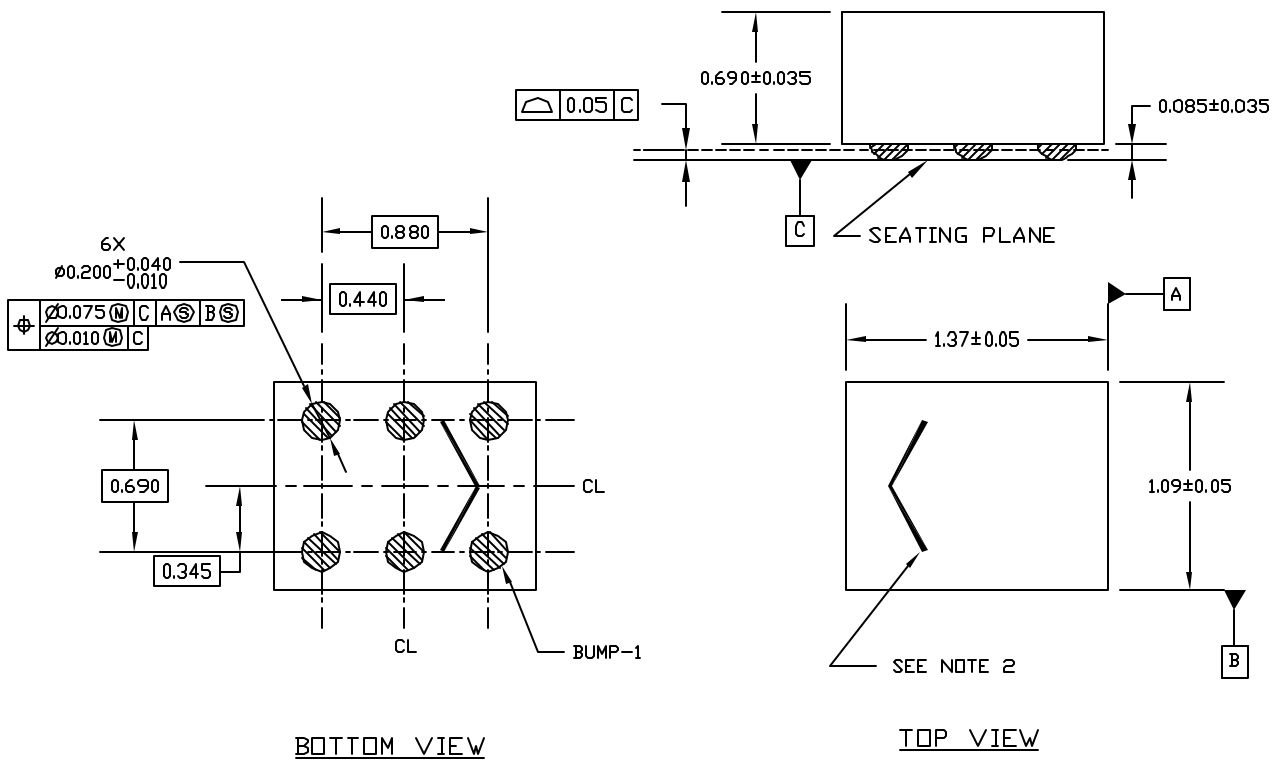

BOTTOM VIEW

TOP VIEW

PACKAGE OUTLINE

SIGNATURE		DATE					
QA APVD:							
ENGR MGR:		DS2417X FLIP CHIP PACKAGE, 0.44 MM PITCH PACKAGE CODE: BF611-1					
ENGR BY:							
CHECK BY:		SIZE	FSCM NO.	DWG NO.	REV		
S. CHINNUSAMY 11/2006		A		56-G7018-001	A		
DRAWN BY:		SCALE			SHEET		
B. MCCARTY 6/15/1999		NONE			1 / 2		

NOTES:

1. DIMENSIONS: MM [INCH]
2. LASER MARK
3. LANDING PAD NOT DEFINED BY SOLDER MASK; FOR PAD CONNECTIONS, SEE TABLE 1

TABLE 1. LAND PAD CONNECTIONS AND CENTER COORDINATES						
NUMBER	NAME	MILLIMETERS		INCHES		
		X	Y	X	Y	
1	VSS	-0.440	-0.345	-0.0173	-0.0136	
2	I _O	0.000	-0.345	0.0000	-0.0136	
3	INT\	0.440	-0.345	0.0173	-0.0136	
4	VDD	0.440	0.345	0.0173	0.0136	
5	X1	0.000	0.345	0.0000	0.0136	
6	X2	-0.440	0.345	-0.0173	0.0136	

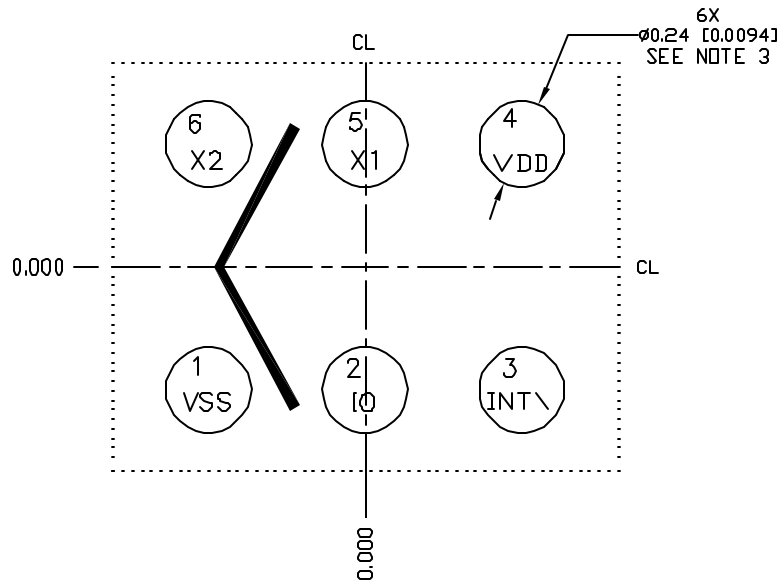

TOP VIEW
PADS NUMBERED COUNTERCLOCKWISE
IN THIS VIEW

RECOMMENDED SUBSTRATE
LAND PATTERN

SIZE A	FSCM NO.	DWG NO. 56-G7018-001	REV A
SCALE NONE	SHEET 2 / 2		