

REVISIONS			
LTR.	DESCRIPTION	DATE	APPROVED
A	NEW DRAWING	08/06	

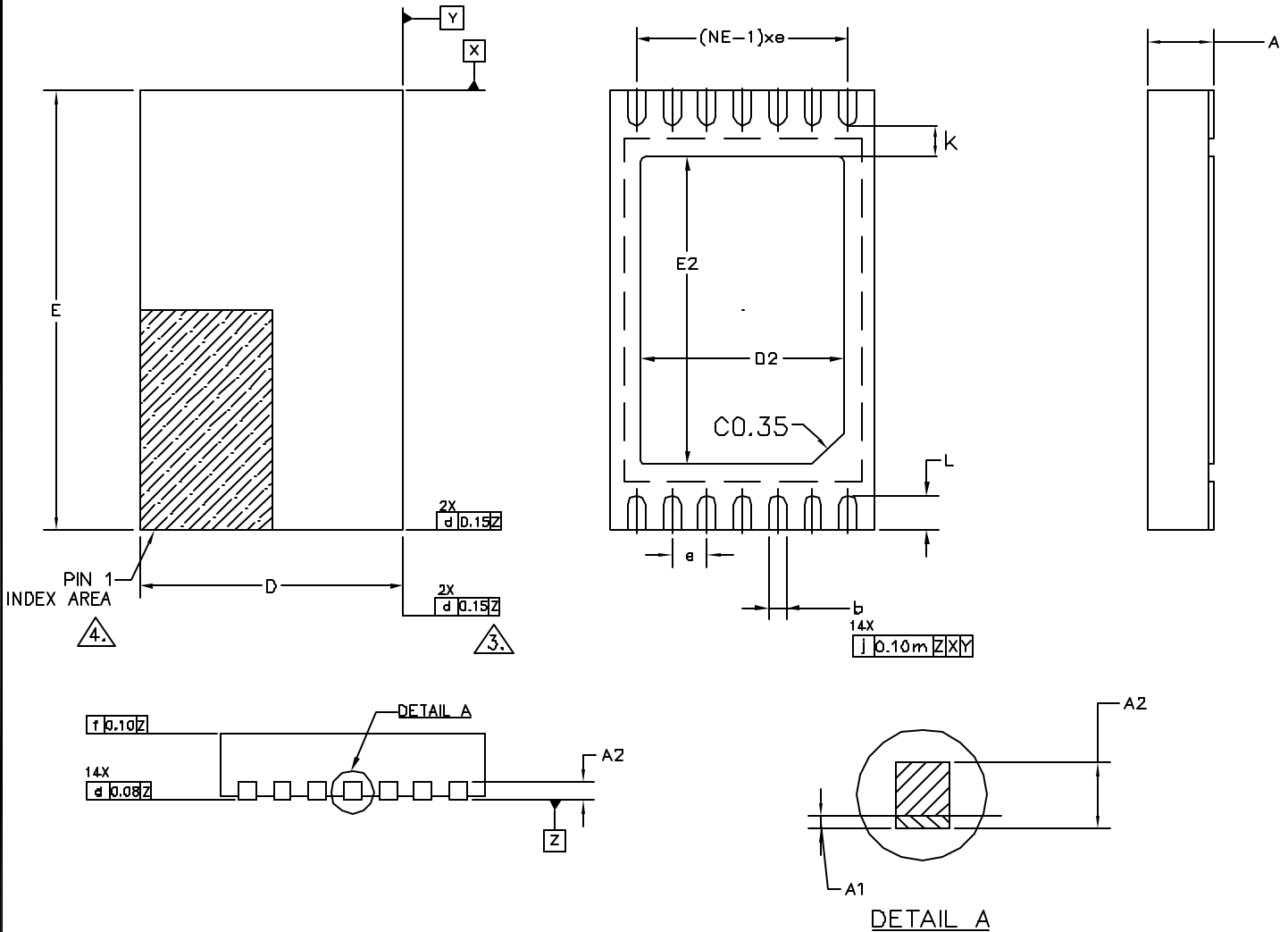

NOTES:

1. DIMENSIONING AND TOLERANCES PER ASME Y14.5M-1994.
2. ALL DIMENSION ARE IN MM. ANGLES IN DEGREES.
3. BILATERAL TOLERANCE ZONE IS APPLIED TO EACH SIDE OF THE PACKAGE BODY.
4. A1 CORNER MUST BE IDENTIFIED BY INK/LASER MARK ON TOP PACKAGE, AND CHAMFERED PAD ON BOTTOM PACKAGE
5. COPLANARITY APPLIES TO THE EXPOSED PAD AS WELL AS THE TERMINALS. COPLANARITY SHALL NOT EXCEED 0.08 mm.
6. WARPAGE SHALL NOT EXCEED 0.10 mm.
7. REFER JEDEC MO-229.

SYM	14 LEAD		
	MIN	NOM	MAX
A	0.70	0.75	0.80
E	4.90	5.00	5.10
D	2.90	3.00	3.10
A1	0.10 MAX		
L	0.195	0.203	0.261
k	0.35 MIN		
A2	0.20 REF		
e	0.40 TYP.		
E2	3.40	3.50	3.60
D2	2.20	2.30	2.40
b	0.15	0.20	0.25
NE	7		

SIGNATURE		DATE					
DOC. CONTROL:							
ENGR. MGR:				TITLE			
MFG. ENGR:				PACKAGE OUTLINE, 14 LEAD TDFN			
CHECKED BY: S. CHINNUSAMY		08/06		SIZE		PART NO.	
DRAWN BY: JFD		08/06		A		56-G0010-001	
				SCALE		SHEET	
				N/A		1 of 1	
						REV. A	