

DIM	INCHES		MILLIMETERS	
	MIN	MAX	MIN	MAX
A	0.110	0.134	2.79	3.40
A1	0.010	---	0.25	---
A2	0.100	0.120	2.55	3.05
B	0.009	0.015	0.22	0.38
D	0.904	0.923	22.95	23.45
E	0.667	0.687	16.95	17.45
E1	0.547	0.555	13.90	14.10
E3	0.486	REF	12.35	REF
e	0.0256	BSC	0.65	BSC
D1	0.783	0.791	19.90	20.10
D3	0.742	REF	18.85	REF
L	0.026	0.037	0.65	0.95
ZD	0.023	REF	0.58	REF
ZE	0.033	REF	0.83	REF
$\alpha$	0°	7°	0°	7°

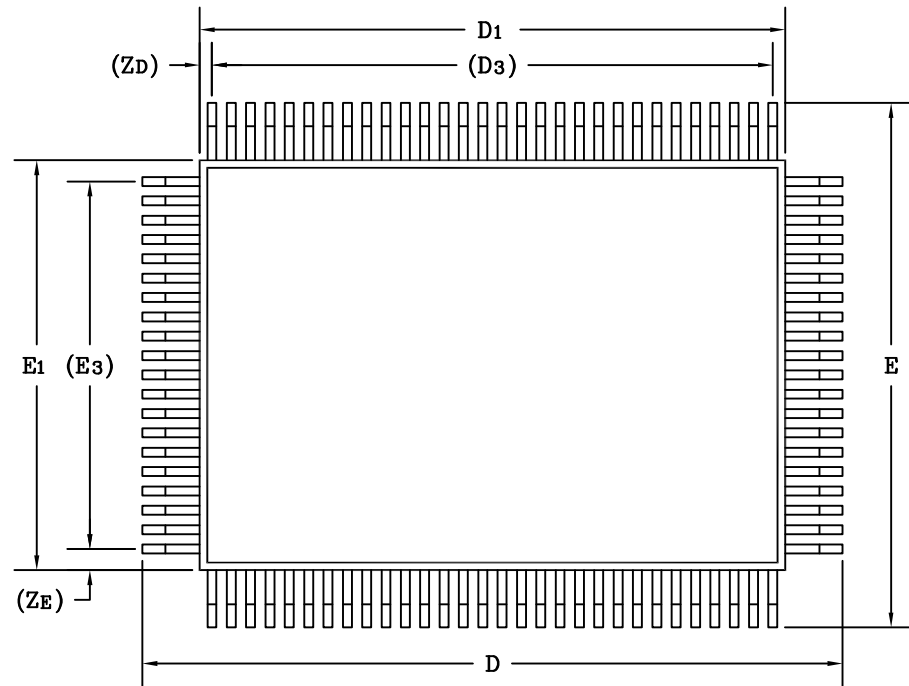

**DETAIL "A"**

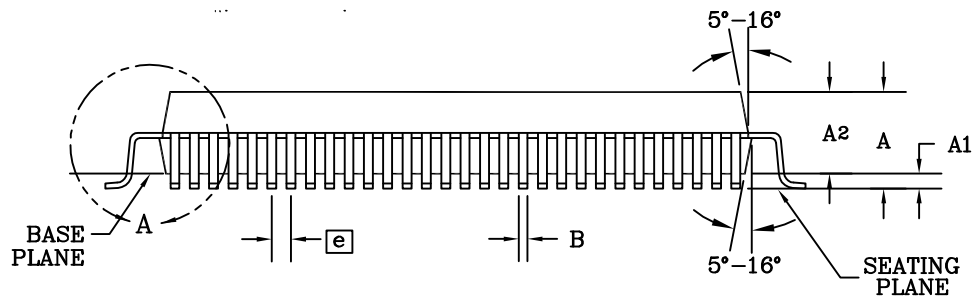
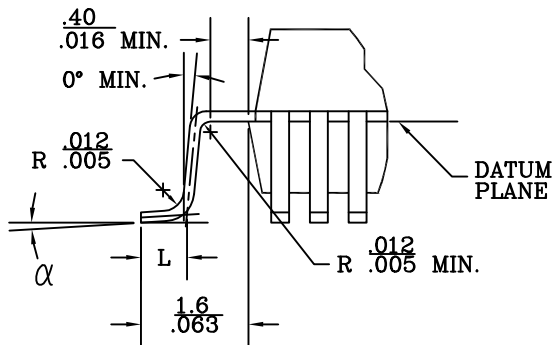

**NOTES:**

1. D1 & E1 DO NOT INCLUDE MOLD FLASH.
2. MOLD FLASH OR PROTRUSIONS NOT TO EXCEED .254mm(.010").
3. CONTROLLING DIMENSION: MILLIMETER.
4. MEETS JEDEC MO-108-CC-1.

<b>MAXIM</b>			
PROPRIETARY INFORMATION			
TITLE: <b>100L MQFP PACKAGE OUTLINE</b>			
APPROVAL	DOCUMENT CONTROL NO. 21-7003	REV A	1/1