



**DOCUMENT TITLE:
MARKETING OUTLINE DRAWING, 20MM X 20MM X 1.4MM, 144L EXPOSED PAD
LQFP**

DOC ID # 21-0300 NEW REV: A

ECN#: HQ EFFECTIVE DATE: 06/20/08

ORIGINATOR: JEFF WALKER

MOST RECENT CHANGES

FROM	TO
DALLAS DOCUMENT CONTROL SYSTEM DOC 56-G6037-002, REV A. LOGO-DALLAS/MAXIM	INITIAL RELEASE INTO MAXIM DOCUMENT CONTROL LOGO-MAXIM

REVISIONS			
LTR.	DESCRIPTION	DATE	APPROVED
A			

SEE DETAIL "A"
(PAGE 2)

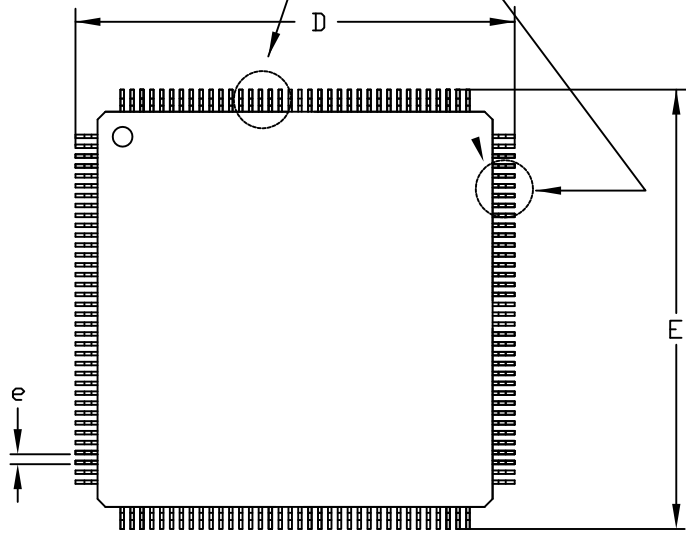

TOP VIEW

SEE DETAIL "C"

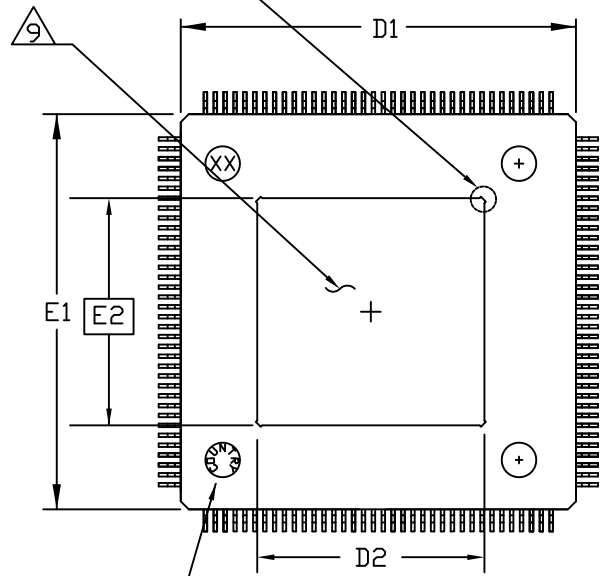

BOTTOM VIEW

C00 (ePAD)

SYMBOL	TQFP PACKAGE VARIATION ALL DIMENSIONS IN MILLIMETERS	
	MIN.	MAX.
	144L, 20x20x1.4	
A	\approx	1.60
A ₁	0.05	0.15
A ₂	1.35	1.45
D	21.80	22.20
D ₁	19.80	20.20
D ₂	9.95	11.52
E	21.80	22.20
E ₁	19.80	20.20
E ₂	9.95	11.52
L	0.45	0.75
M	0.11	\approx
N	144	
e	0.50 BSC	
b	0.17	0.27
b ₁	0.17	0.23

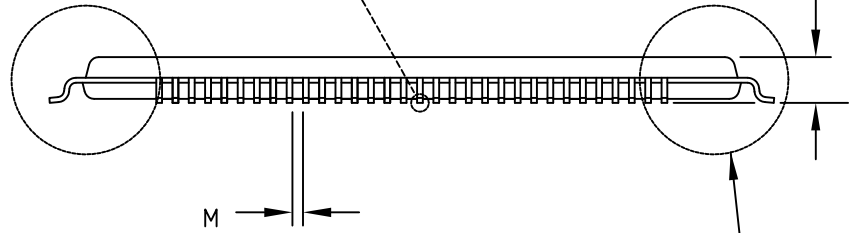
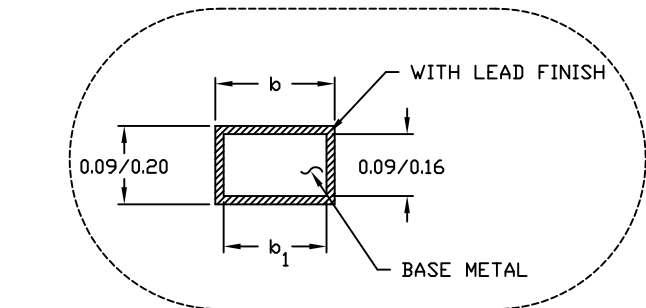

SIDE VIEW

SEE DETAIL "B"



SIGNATURE		DATE		MARKETING OUTLINE DRAWING 20MM X 20MM X 1.4MM, 144L EXPOSED PAD LQFP							
DOC. CONTROL:								SIZE	FSCM NO.	PART NO.	REV.
ENGR. MGR:								A		21-0300	A
MFG. ENGR:				SCALE N/A				SHEET 1 of 2			
CHECKED BY: TWM		10/05									
DRAWN BY: JFD		10/05									

ODD LEAD SIDES

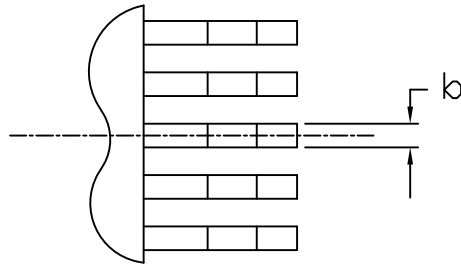

EVEN LEAD SIDES

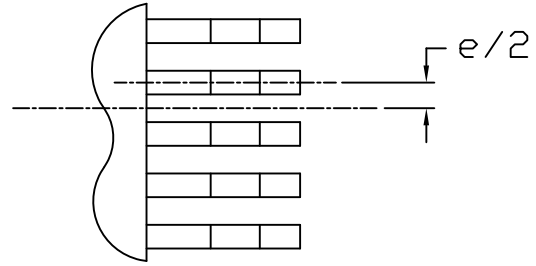

DETAIL "A"

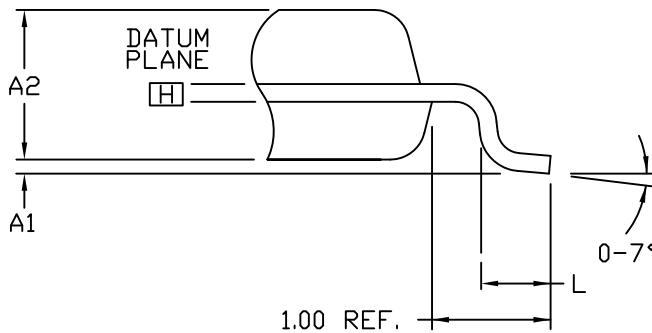

DETAIL "B"

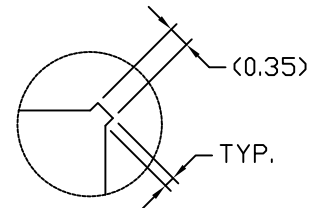

DETAIL "C"
(EXPOSED PAD CORNER DETAIL)

NOTES:

1. ALL DIMENSIONING AND TOLERANCING CONFORM TO ANSI Y14.5-1982.
2. DATUM PLANE [H] LOCATED AT MOLD PARTING LINE AND COINCIDENT WITH LEAD, WHERE LEAD EXITS PLASTIC BODY AT BOTTOM OF PARTING LINE.
3. DIMENSIONS D1 AND E1 DO NOT INCLUDE MOLD PROTRUSION. ALLOWABLE MOLD PROTRUSION IS 0.254 MM ON D1 AND E1 DIMENSIONS.
4. THE TOP OF PACKAGE IS SMALLER THAN THE BOTTOM OF PACKAGE BY 0.15 MILLIMETERS.
5. DIMENSION b DOES NOT INCLUDE DAMBAR PROTRUSION. ALLOWABLE DAMBAR PROTRUSION SHALL BE 0.08mm TOTAL IN EXCESS OF THE b DIMENSION AT MAXIMUM MATERIAL CONDITION.
6. CONTROLLING DIMENSION: MILLIMETER.
7. THIS OUTLINE CONFORMS TO JEDEC PUBLICATION 95 REGISTRATION MS-026.
8. LEADS SHALL BE COPLANAR WITHIN 0.08 MM.
9. THE EXPOSED PAD IS COINCIDENT WITH THE TOP OR BOTTOM SIDE OF THE PACKAGE AND NOT ALLOWED TO PROTRUDE BEYOND THAT SURFACE.

SIGNATURE		DATE		MAXIM			
DOC. CONTROL:				TITLE MARKETING OUTLINE DRAWING			
ENGR. MGR:				20MM X 20MM X 1.4MM, 144L EXPOSED PAD LQFP			
MFG. ENGR:				SIZE	FSCM NO.	PART NO.	REV.
CHECKED BY:	TWM	10/05	A			21-0300	A
DRAWN BY:	JFD	10/05		SCALE	N/A	SHEET	2 of 2

REVISION HISTORY

REV	CHANGES MADE	DATE	INIT.
A	ECN# HQ-08-XXXX. INITIAL RELEASE INTO MAXIM DOCUMENT CONTROL. LOGO-MAXIM	06/20/08	JW



TITLE: MARKETING OUTLINE DRAWING, 20MM X 20MM X 1.4MM,
144L EXPOSED PAD LQFP

DOCUMENT I.D.
21-0300

REVISION
A

PAGE
3