

Real-Time Clocks

Product Guide



Learn More

	Page
Accurate Timekeeping	2
High-ESR Crystals	4
I ² C Interface	5
SPI/3-Wire Interface	6

Page

Parallel Interface	8
Serial Selector Guide	10
Parallel Selector Guide	11

Unprecedented Timekeeping Accuracy from < $\pm 5\text{ppm}$ down to < $\pm 2\text{ppm}$

Maxim's accurate RTCs maintain precise time across a broad temperature range. A variety of products with the newest technology innovations are available, such as a MEMs-based accurate RTC that provides enhanced reliability and ruggedness as well as less susceptibility to aging, EMI, and vibration. This RTC provides low-current operation and accuracy comparable to crystal-based solutions.

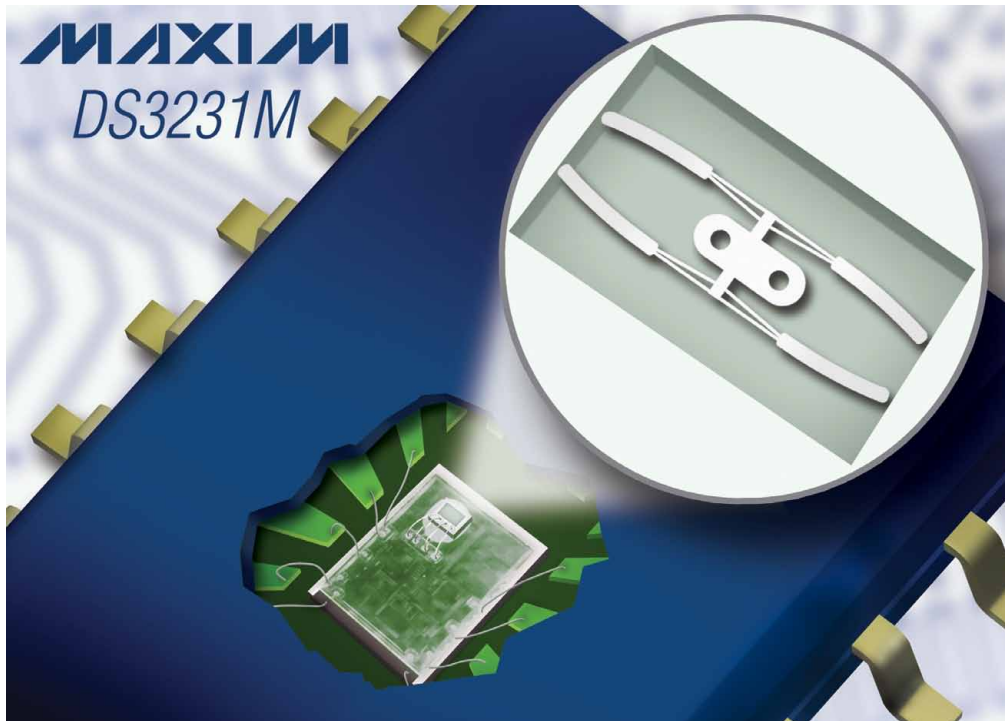

Accurate RTCs

Part	Accuracy (sec/day)	Frequency Output (kHz)	Operating Voltage (V)	Interface	User Memory (Bytes)	Resonator Type
DS3231M	± 0.432	32.768	2.3 to 5.5	I ² C	—	MEMs
DS3231S	± 0.3				—	
DS3232					236	
DS3234				SPI™	256	
DS32B35	I ² C			2K		
DS32C35				8K		

SPI is a trademark of Motorola, Inc.

Unprecedented Timekeeping Accuracy (cont.)

Maxim's accurate timekeeping products are designed to provide improved performance over a standard tuning-fork crystal. By nature, crystals have frequency variations due to changes in ambient temperature. Over the -40°C to +85°C temperature range, the frequency of a crystal can deviate by 100s of parts per million. This results in time inaccuracies of hours per year. In contrast, Maxim's accurate RTCs provide accuracies as good as 2 minutes per year.

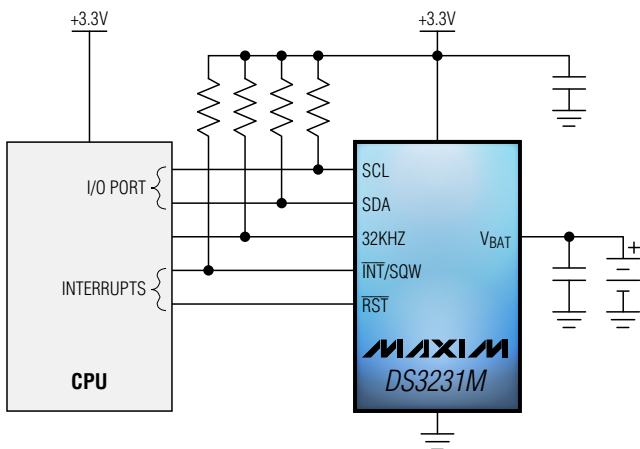
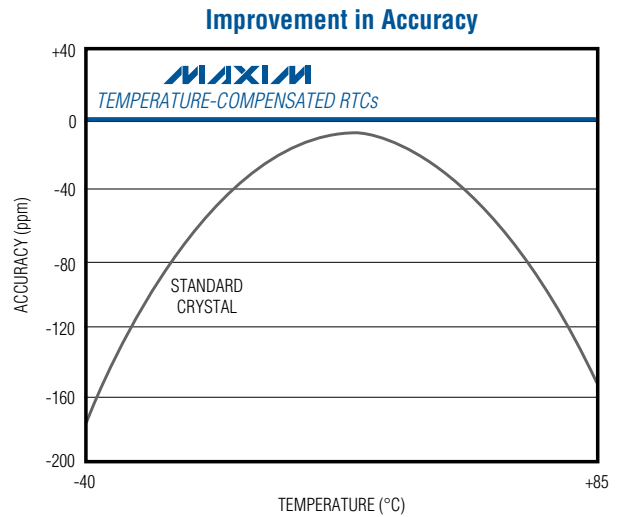

With six devices to choose from, users needing accurate timekeeping are provided a variety of interface options, memory options, and package sizes ranging from the 300 mil, 20-pin SO down to the tiny 150 mil, 8-pin SO (DS3231MZ+). Each device is individually calibrated across its specified temperature range and guaranteed accurate to datasheet specifications. All devices are designed to support battery-backed operation and operate in low-current modes when supplied power through the V_{BAT} terminal. They are also RoHS compatible, and the DS3231M device is fully RoHS compliant.

Applications that include utility meters, fleet management, security, access control, and automobiles are finding accurate timekeeping essential to the operation of the end equipment. Whether accurate timekeeping is used for billing purposes, time stamping of critical event transactions, or aiding in satellite capture for GPS applications, accurate RTCs provide the most suitable and cost-effective method for implementing accuracy in end equipment.



Metering



Fleet Management



Computing and Servers



Automotive



Security and Access Control

High-ESR RTCs Allow Use of Surface-Mount Crystals for Overall Timekeeping Footprint Reduction

Today’s surface-mount 32.768kHz crystals offer a reduced footprint for timekeeping designs, but have a high equivalent series resistance (ESR). Most of the real-time clocks on the market require an ESR of less than 50kΩ, which prevents the designer from taking advantage of these small crystals. However, Maxim’s newer RTCs are capable of driving crystals with an ESR up to 100kΩ (the highest drive level in the industry), thus allowing the use of these small crystals for an overall reduction in timekeeping design size.

DS1343*/DS1344*

Extremely Low Standby Current Extends Backup Supply Life

- Low timekeeping current of 250nA (typ)
- Compatible with crystal ESR up to 100kΩ
 - Versions available to support either 6pf or 12.5pf crystals
- Burst mode for reading/writing successive addresses in clock/RAM
- Supports SPI modes 1 and 3
- Maintains time down to 1.15V (typ)
- Two time-of-day alarms with two interrupt outputs
- 96-byte battery-backed SRAM for data storage
- 20-pin TSSOP or 14-pin TDFN package

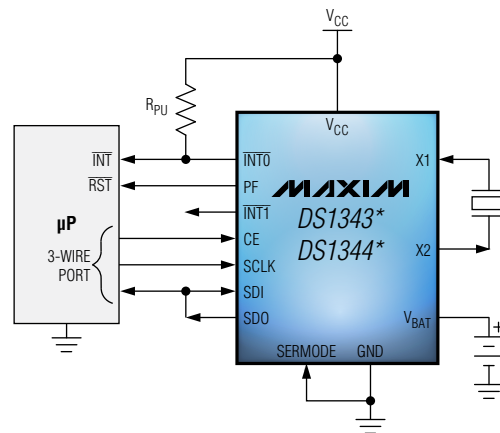

NOTE: SHOWN IN 3-WIRE I/O CONFIGURATION.

RTCs for Driving Higher ESR Crystals

Part	Interface	Voltage (V)	Calendar Format	Clock Format	SRAM (Bytes)	Power Switching	Trickle Charger	Interrupts	Square Wave	Other Features
DS1340	I ² C	1.8, 3.0, 3.3, 5.0	YY-MM-DD	HH:MM:SS	—	✓	✓	2 alarms	—	Calibration
DS1341	I ² C	1.8 to 5.5			—				Prog	Sync input
DS1342	I ² C				—				—	Burst-mode data transfer
DS1343*	SPI or 3-wire	1.8, 3.0, 3.3, 5.0			96	✓	✓		—	
DS1344*			—							

*Future product—contact factory for availability.

I²C Interface RTCs Provide Lowest Cost Timekeeping and System Flexibility

Maxim's I²C single-supply RTCs are the lowest cost timekeeping option due to their simple, small circuit and reduced pin count. Those with power switching maintain time monitoring during system power off by offering automatic transition to a backup power supply when the main power source is no longer available.

DS1341/DS1342

Compatible with High-ESR Crystals While Offering Lowest Possible Current to Extend Battery Life

- Compatible with crystal ESR up to 100kΩ
- Low, 220nA timekeeping current
- Maintains time down to 1.15V (typ)
- Optional sync to external clock source
- 3mm x 3mm, 8-pin μSOP

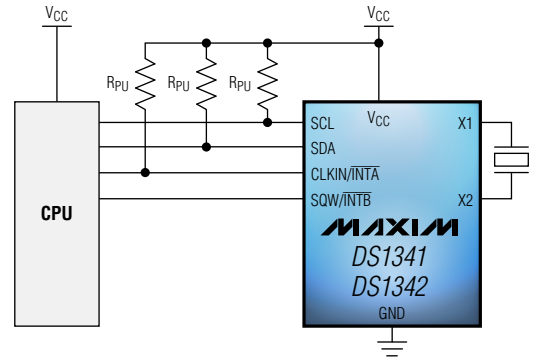

DS1339

Multiple Programmable Features Provide System Flexibility

- Programmable square-wave output, trickle-charge capability, and two time-of-day alarms
- Oscillator stop flag
- Surface-mount 16-pin SOIC with an integrated crystal (DS1339C) or 8-pin μSOP (DS1339U)

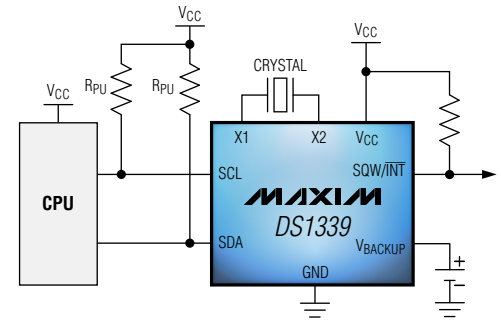

RTCs with I²C Interface

Part	Full Operating Voltage (V)	Timekeeping Voltage (V)	Power Switching	Calendar Format	Clock Format	Interrupt	Square Wave	Other Features			
DS1307	5.0	2.0 to 5.5	✓	YY-MM-DD	HH:MM:SS	—	Prog	—			
DS1337	1.8 to 5.5	1.3 to 5.5				2 alarms		Osc stop flag			
DS1338	1.8, 2.0, 3.3, 5.0		✓			—		—			
DS1339	2.0, 3.0, 3.3, 5.0		✓			2 alarms	Osc stop flag				
DS1340	1.8, 2.0, 3.3, 5.0		✓			—	Calibration				
DS1341/42	1.8 to 5.5					2 alarms	Ext sync				
DS1374	1.8, 2.0, 3.3, 5.0		✓			Binary counter		Watchdog/alarm	Prog	μP reset	
DS1388	3.0, 3.3, 5.0		✓			YY-MM-DD	HH:MM:SS:hh				
DS1371	1.7 to 5.5						Binary counter		Watchdog/alarm**	Prog**	Osc stop flag
DS1372	2.4 to 5.5										Serial number
DS1629	2.2 to 5.5		2.2 to 5.5		YY-MM-DD	HH:MM:SS:hh	1 alarm	—	Temp sensor		
DS1672	2.0, 3.0, 3.3	1.3 to 3.63	✓	Binary counter		—	—	μP reset			
DS1678	5.0	2.6 to 5.5	✓	Binary counter		1 alarm	—	Event logger			
DS3231/32	3.3	2.3 to 5.5	✓	YY-MM-DD	HH:MM:SS	2 alarms	Prog	Temp sensor, μP reset			
DS32B35			✓					2KB FRAM			
DS32C35			✓					8KB FRAM			

**Single output configurable as an interrupt or square wave.

SPI/3-Wire Interface RTCs Provide Fast Data Communications in a Small Package

Maxim’s SPI and 3-wire interface RTCs offer clock rates up to 4MHz for faster data communications, while still providing the advantages of a pin count as low as 10 pins and small packages down to 9mm².

DS1390/DS1391/DS1394

Industry’s Most Highly Integrated SPI RTCs with Trickle Charger Have the Smallest Footprint in Their Class

- 3mm x 3mm, 10-pin μ SOP
- Output pin configurable as interrupt or square wave (DS1390/DS1394)
- One time-of-day alarm
- Power-fail detect-and-switch circuitry
- Reset output/debounced input (DS1391)
- Supports SPI modes 1 and 3 (DS1390/DS1391)
- Supports SPI modes 0 and 2 (DS1394)
- SCLK frequency of 4MHz at 3.0V and 3.3V, 1MHz at 1.8V
- Three operating voltage ranges: 1.8V \pm 5%, 3.0V \pm 10%, and 2.97V to 5.5V

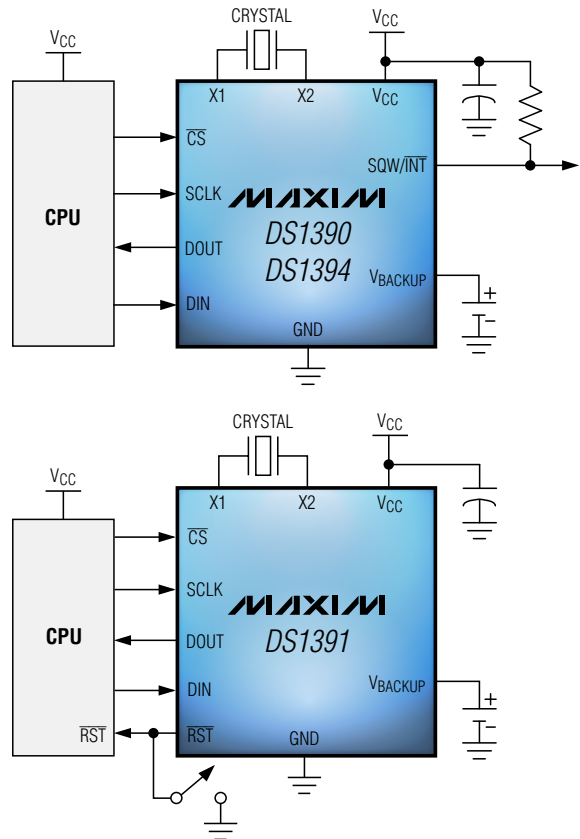

RTCs with SPI Interface

Part	Voltage (V)	Calendar Format	Clock Format	NV Memory (Bytes)	Interrupts	Square Wave	Trickle Charger	Other Features
DS1305	2.0 to 5.5	YY-MM-DD	HH:MM:SS	96	2 alarms	—	✓	Power-fail output
DS1306						1Hz, 32kHz		Burst-mode data transfer
DS1343*	1.8, 3.0, 3.3, 5.0					—		Power-fail output
DS1344*						—		—
DS1390	1.8, 3.0, 3.3, 5.0		HH:MM:SS:hh	—	1 alarm**	Prog**		—
DS1391				—	1 alarm	—		μ P reset
DS1394				—	1 alarm**	Prog**		—
DS3234	3.3		HH:MM:SS	—	256	2 alarms		Prog

*Future product—contact factory for availability.

**Single output configurable as an interrupt or square wave.

SPI/3-Wire Interface RTCs (cont.)

Data In and Data Out in a Single I/O Pin Frees a Package Pin for Other Functions

Many timekeeping applications require the use of either the square wave or interrupt function. If only one pin is available, the designer must choose which function to invoke. However, the 3-wire interface frees one of the SPI interface pins, thus allowing both the square wave and interrupt functions to be available at the same time.

DS1392/DS1393

Smallest 3-Wire RTCs with Trickle Charger Have Industry's Broadest Feature Set

- Separate SQW and INT outputs (DS1392)
- Output pin configurable as interrupt or square wave (DS1393)
 - Programmable SQW frequency of 32.768kHz, 8.192kHz, 4.096kHz, or 1Hz
- One time-of-day alarm
- Power-fail detect-and-switch circuitry
- Reset output/debounced input (DS1393)
- Three operating voltage ranges: 1.8V \pm 5%, 3.0V \pm 10%, and 2.97V to 5.5V
- 3mm x 3mm, 10-pin μ SOP

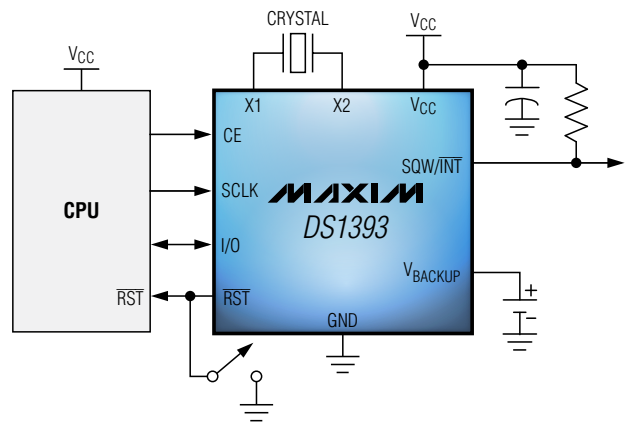
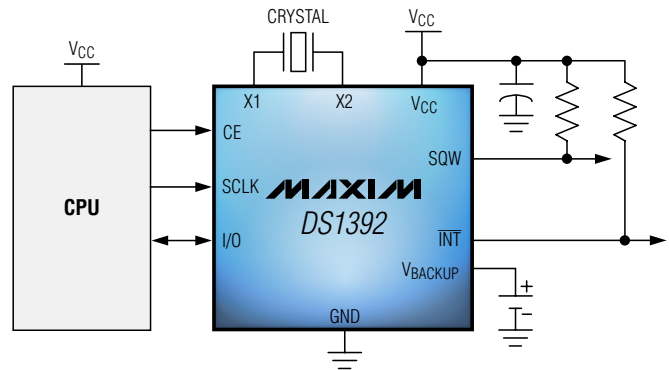

RTCs with 3-Wire Interface

Part	Voltage (V)	Calendar Format	Clock Format	NV Memory (Bytes)	Interrupts	Square Wave	Trickle Charger	Other Features		
DS1302	2.0 to 5.5	YY-MM-DD	HH:MM:SS	31	—	—	✓	Burst-mode data transfer		
DS1305				—	—	Power-fail output				
DS1306				1Hz, 32kHz	Burst-mode data transfer					
DS1343*	1.8, 3.0, 3.3, 5.0		—	96	2 alarms	—		Power-fail output		
DS1344*			—			—				
DS1392			Prog			—				
DS1393	—		—	—	—	1 alarm**		Prog**	μ P reset	
DS1670	3.3		HH:MM:SS	—	—	Watchdog, alarm		—	—	μ P reset, NV SRAM control, ADC
DS1673	3.0, 5.0			—				—		
DS1677	5.0	—		—			μ P reset, NV SRAM control, ADC, PFI/PFO			

*Future product—contact factory for availability.

**Single output configurable as an interrupt or square wave.

Parallel Interface RTCs Allow the Fastest Data Transfer

The byte-wide, or parallel, interface allows RTCs the fastest data transfer with access times below 100ns. This makes parallel interface RTCs a good choice for systems that must quickly time-stamp events or share an interface with standard SRAM memory.

DS1500/DS1501/DS1511

Support System Power-On from Date/Day/Time Alarm or Key Closure/Modem-Detect Signal

- Programmable watchdog timer and RTC alarm
- Accuracy of better than 1min/month at +25°C (DS1511)
- 3.3V or 5.0V operation
- Day-of-week/date alarm register
- Precision power-on reset
- Battery-voltage-level indicator flag
- 256 bytes battery-backed SRAM
- IC with external battery and crystal (DS1500/DS1501) or stand-alone encapsulated DIP module with embedded battery and crystal (DS1511)
- Auxiliary battery input

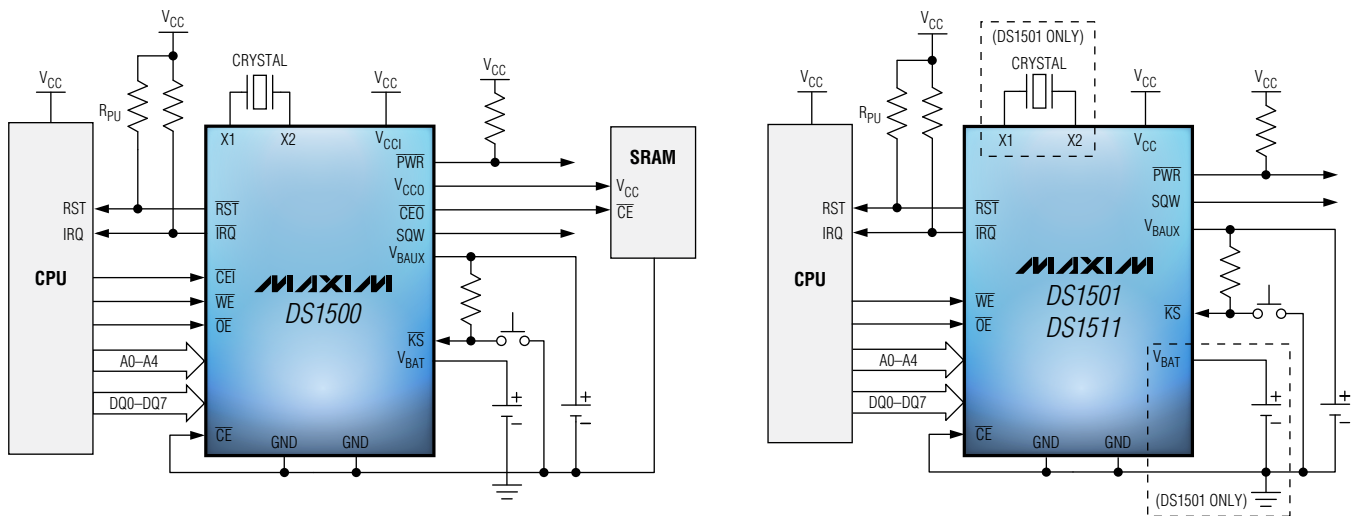

RTCs with Standard Parallel Interface and Power Switching

Part	Voltage (V)	Clock Format	User SRAM (Bytes)	Power Switching	Interrupts	Square Wave	NV SRAM Control	Other Features			
DS1318	3.3	Binary counter	—		Alarm, periodic	Prog		Event timer			
DS1500	3.3, 5.0	HH:MM:SS	256	✓	Watchdog, alarm, periodic	32kHz	✓	μP reset, wakeup			
DS1501/11											
DS1553									8K	μP reset, low-battery flag	
DS1554									32K		
DS1556									128K		
DS1557									512K		
DS1558									—		✓
DS1742									2K		Low-battery flag
DS1743									8K		
DS1744									32K		
DS1746									128K		
DS1747	512K										
DS3065WP	3.3		1M		Watchdog, alarm	—		μP reset, low-battery flag			

Phantom Interface RTCs Need No Dedicated Address Space, Regardless of Memory Size

The phantom interface allows the RTC to communicate serially across the D0 line of a standard parallel interface bus. The term “phantom” comes from the fact that the RTC is invisible until a unique 64-bit pattern is recognized. Thus, there is no requirement for a dedicated address space for the RTC, and the same firmware can access the RTC regardless of the system memory block size.

DS1315

Nonvolatile Memory Controller Contains All Support Circuitry for Converting CMOS RAM to NV Memory

- No address space required to communicate with RTC
- Provides NV controller functions for battery-backup SRAM
- Supports redundant battery attachment for high-reliability applications
- Full 10% V_{CC} operating range
- 3.3V or 5.0V operation
- 16-pin SO, 20-pin TSSOP, or 16-pin PDIP

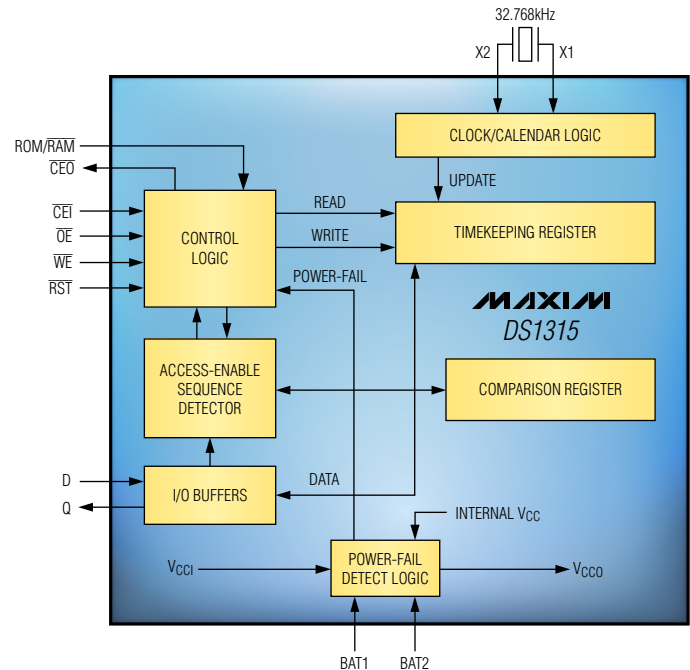

RTCs with Phantom Parallel Interface

Part	Voltage (V)	Calendar Format	Clock Format	User SRAM (Bytes)	NV SRAM Control	DIP Module	PowerCap	BGA Module
DS1315	3.3, 5.0	YY-MM-DD	HH:MM:SS:hh	—	✓			
DS1243	5.0			8K				
DS1244	3.3, 5.0			32K	✓	✓		
DS1248				128K				
DS1251				512K				
DS1254	3.3			2M			✓	

Serial Selector Guide

	Part	Voltage (V)	Clock Format	SRAM/EEPROM/FRAM (Bytes)	Power Switching	Trickle Charger	Interrupts	Square Wave	Other Features
2-Wire or I ² C	DS1307	5.0	HH:MM:SS	S: 56	✓		—	Prog	—
	DS1337	1.8 to 5.5		—			2 alarms		Osc stop flag
	DS1338	1.8, 3.0, 3.3, 5.0		S: 56			—		—
	DS1339			—	✓		2 alarms	Osc stop flag	
	DS1340			—	✓		—	Calibration	
	DS1341	1.8 to 5.5		—			2 alarms	Prog	Sync input
	DS1342			—			—	—	
	DS1371	1.7 to 5.5	Binary counter	—			Watchdog and alarm	Prog**	—
	DS1372	2.4 to 5.5		—					Serial number
	DS1374	1.8, 3.0, 3.3, 5.0		—	✓	✓		—	Power-fail reset
	DS1375	1.7 to 5.5	HH:MM:SS	S: 16			2 alarms	Prog	—
	DS1388	3.0, 3.3, 5.5	HH:MM:SS:hh	E: 512	✓	✓	Watchdog and alarm	—	Power-fail reset
	DS1629	2.2 to 4.0	HH:MM:SS	S: 32			1 alarm	Prog	Temp sensor
	DS1672	2.0, 3.0, 3.3	Binary counter	—	✓	✓	—	—	Power-fail reset
	DS1678	5.0	HH:MM:SS	S: 32			1 alarm	—	Event recorder
	DS1682	2.5 to 5.5	Binary counter	E: 10				—	RC oscillator
	DS3231	3.3	HH:MM:SS	—	✓		2 alarms	Prog	Temp sensor
DS3232	S: 236								
DS32B35	F: 2K								
DS32C35	F: 8K								
3-Wire	DS1302	2.0 to 5.5	HH:MM:SS	S: 31			—	—	Burst-mode data transfer
	DS1305			S: 96			2 alarms	1Hz, 32kHz	
	DS1306						—		
	DS1343*	1.8, 3.0, 3.3, 5.0	—			—			
	DS1344*		—			—			
	DS1392	1.8, 3.0, 3.3, 5.0	HH:MM:SS:hh	—	✓		1 alarm	Prog	Power-fail reset
	DS1393			—					—
	DS1670	3.3	HH:MM:SS	—			Watchdog and alarm	—	Power-fail reset, NV SRAM control, ADC
DS1673	3.0, 5.0	HH:MM:SS	—			—	—	Power-fail reset, NV SRAM control, ADC	
DS1677	5.0	HH:MM:SS	—			—	—	Power-fail reset, NV SRAM control, ADC, PFI/PFO	
SPI	DS1305	2.0 to 5.5	HH:MM:SS	S: 96	✓	✓	2 alarms	—	Burst-mode data transfer
	DS1306							1Hz, 32kHz	
	DS1343*							—	
	DS1344*	—							
	DS1390	1.8, 3.0, 3.3, 5.0	HH:MM:SS:hh	—	✓	✓	1 alarm	Prog	—
	DS1391			—				—	Power-fail reset

*Future product—contact factory for availability.

**Single output configurable as an interrupt or square wave.

Parallel Selector Guide

	Part	Voltage (V)	Clock Format	User SRAM (Bytes)	Power Switching	Interrupts	Square Wave	NV SRAM Control	Other Features
Mux Bus	DS12885/87/87A	5.0	HH:MM:SS	114	✓	Alarm, periodic	Prog		µP reset, RAM clear (DS12887A)
	DS12R885/887	3.0, 5.0		114					µP reset, RAM clear
	DS12C887/887A	5.0		113					µP reset
	DS12CR887	3.0, 5.0		114					µP reset
	DS1685/87			114 + 128					µP reset, RAM clear, serial number, wake-up
	DS17285/287/485/487/885/887			114 + xK					
Phantom	DS1315	3.3, 5.0	HH:MM:SS:hh	—	✓	—	—	✓	—
	DS1243	5.0		8K		—		—	
	DS1244	3.3, 5.0		32K		—		—	
	DS1248			128K		—		—	
	DS1251			512K		—		—	
	DS1254	3.3		2M		—		—	
Bytewide	DS1318	3.3	Binary counter	—	✓	Alarm, periodic	Prog	✓	Event timer
	DS1500	3.3, 5.0	HH:MM:SS	256		Watchdog and alarm, periodic	32kHz		µP reset, wake-up
	DS1501					Watchdog, alarm	—	µP reset, low-battery flag	
	DS1511			—					
	DS1553			8K					
	DS1554			32K					
	DS1556			128K					
	DS1557			512K					
	DS1558			—			✓		
	DS1742			2K			Low-battery flag		
	DS1743			8K					
	DS1744			32K					
	DS1746			128K					
	DS1747			512K					
	DS3065WP			3.3		1M	Watchdog, alarm	—	µP reset, low-battery flag