



# Dual, 2-Wire Hall-Effect Sensor Interface with Diagnostics

MAX9921

## General Description

The MAX9921 provides a single chip solution to interface two 2-wire Hall-effect sensors to a low-voltage micro-processor ( $\mu$ P). This device supplies and monitors the current drawn by two Hall-effect sensors, filters the sensed current level, and outputs the corresponding logic level.

The MAX9921 includes input diagnostics and fault protection. These features allow the device to determine fault conditions such as open inputs, inputs shorted to the battery, and inputs shorted to ground. If the MAX9921 detects any of these conditions at either IN1 or IN2, the device shuts off the current to the corresponding input.

The MAX9921 protects the Hall sensors from supply transients up to 60V at the BAT supply. Normal operating supply voltage ranges from 6V to 18V. If the battery voltage is out of range, the MAX9921 shuts off the current to the Hall sensors.

The MAX9921 provides an 80 $\mu$ s blanking time following Hall sensor power-up or restart. The open-drain logic outputs are compatible with logic levels up to 5.5V.

The MAX9921 is available in a small 10-pin  $\mu$ MAX<sup>®</sup> package and is specified over the -40°C to +125°C automotive temperature range.

## Applications

Door Modules	Powered Lift Gate Controllers
Window Lifters	Powered Running Boards
Seat Movers	Seatbelt Buckles
Electric Sunroofs	

## Features

- ◆ Withstands 60V at BAT Supply and Hall Inputs
- ◆ 6V to 18V Operating Voltage Range
- ◆ Provides Supply Current and Interfaces to Two 2-Wire Hall Sensors
- ◆ Error Output with Diagnostics of Hall Inputs and BAT Voltage
- ◆ Protects Hall Sensors from Overvoltage by Isolating them from Supply Transients
- ◆ Hall Inputs Protected from Short to Ground
- ◆ Ramps Current to Hall Sensors at 4mA/ $\mu$ s
- ◆ Output Enable Input Allows Multiplexing of Outputs from Multiple MAX9921s
- ◆ Hall Output Filtering
- ◆ Hall Sensor Blanking Following Hall Sensor Power-Up or Restart
- ◆ Low-Power Shutdown, Controlled with OE and DIAG Inputs
- ◆ Operates with  $\pm$ 2V Ground Shifts Between Hall Sensor and MAX9921

## Ordering Information

PART	TEMP RANGE	PIN-PACKAGE
MAX9921AUB+T	-40°C to +125°C	10 $\mu$ MAX

+ Denotes a lead-free package.  
T = Tape and reel.

Pin Configuration appears at end of data sheet.

## Typical Application Circuit

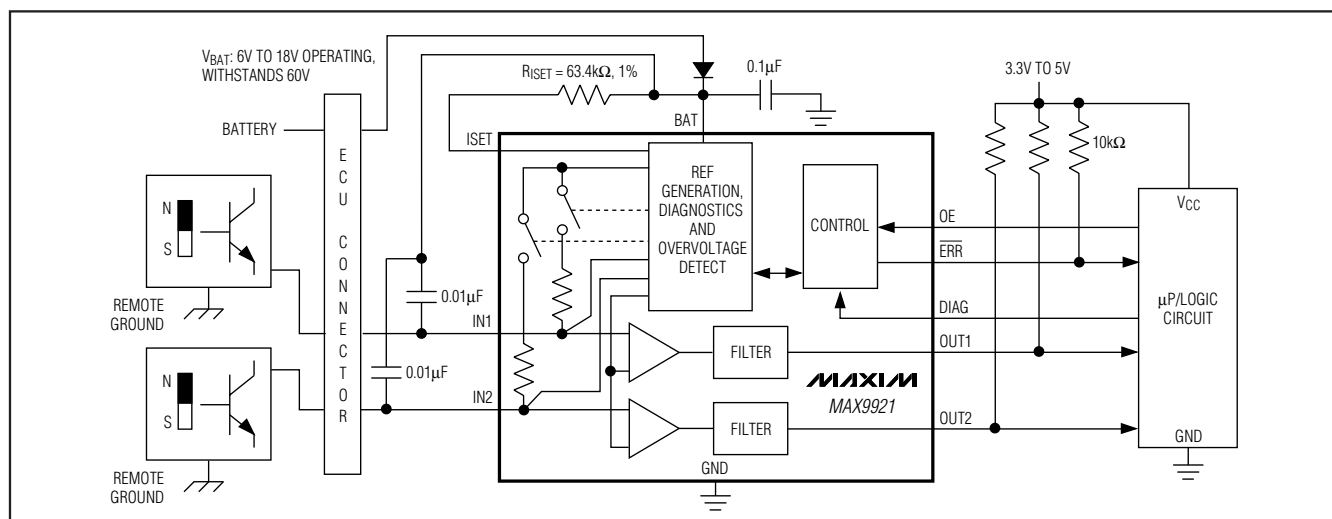

$\mu$ MAX is a registered trademark of Maxim Integrated Products, Inc.



Maxim Integrated Products 1

For pricing, delivery, and ordering information, please contact Maxim Direct at 1-888-629-4642, or visit Maxim's website at [www.maxim-ic.com](http://www.maxim-ic.com).

# Dual, 2-Wire Hall-Effect Sensor Interface with Diagnostics

## ABSOLUTE MAXIMUM RATINGS

BAT to GND	-0.3V to +60V	Current into IN1, IN2	±100mA
ISET to BAT	-2.0V to +0.3V	Continuous Power Dissipation (T <sub>A</sub> = +70°C)	
IN1, IN2 to GND	-5.0V to the lower of +60V or (V <sub>BAT</sub> + 1V)	10-Pin μMAX (derate 5.6mW/°C above +70°C)	444.4mW
DIAG, OE to GND	-0.3V to +6.0V	Operating Temperature Range	-40°C to +125°C
OUT1, OUT2, ERR to GND	-0.3V to +6.0V	Junction Temperature	+150°C
Short-Circuit Duration of OUT1, OUT2, ERR to GND	or to 5.5V (individually)	Storage Temperature Range	-65°C to +150°C
Current into Any Pin Except IN1, IN2	Continuous ±20mA	Lead Temperature (soldering, 10s)	+300°C

Stresses beyond those listed under "Absolute Maximum Ratings" may cause permanent damage to the device. These are stress ratings only, and functional operation of the device at these or any other conditions beyond those indicated in the operational sections of the specifications is not implied. Exposure to absolute maximum rating conditions for extended periods may affect device reliability.

## DC ELECTRICAL CHARACTERISTICS

(V<sub>BAT</sub> = 13.6V, V<sub>DIAG</sub> = 0V, V<sub>OE</sub> = 5V, IN1 = IN2 = no connection, R<sub>ISET</sub> = 63.4kΩ, R<sub>PU</sub> = 10kΩ at ERR, OUT1 and OUT2, T<sub>A</sub> = -40°C to +125°C, unless otherwise noted. Typical values are at T<sub>A</sub> = +25°C.) (Note 1)

PARAMETER	SYMBOL	CONDITIONS	MIN	TYP	MAX	UNITS
<b>GENERAL</b>						
BAT Supply Range	V <sub>BAT</sub>		6		18	V
V <sub>BAT</sub> Low for ERR Output Active	V <sub>BL</sub>		5.2			V
V <sub>BAT</sub> High for ERR Output Active	V <sub>BH</sub>				22	V
BAT Supply Current	I <sub>BAT</sub>	Normal mode		1	1.3	mA
	I <sub>SD</sub>	Shutdown mode, V <sub>OE</sub> = V <sub>DIAG</sub> = 0V			1	μA
<b>HALL INPUTS (IN1 and IN2)</b>						
Input Current for Output High	I <sub>IH</sub>				-11.5	mA
Input Current for Output Low	I <sub>IL</sub>		-7.2			mA
Input Current Hysteresis for High/Low Detection	I <sub>IN,HYS</sub>			0.76		mA
Input Pullup Impedance	R <sub>PU</sub>	V <sub>BAT</sub> = 6V, inputs IN1, IN2 with I <sub>IN</sub> = -14mA		50		Ω
Input Voltage Interpreted as Shorted to Battery	V <sub>SB</sub>	Measured with respect to V <sub>BAT</sub>			100	mV
Current Range Interpreted as Open Circuit	I <sub>OC</sub>		-2		+0.02	mA
Current Level Interpreted as Shorted Sensor to Ground	I <sub>SC</sub>	Not a sustained condition, reverts to -50μA when detected			-23	mA

# Dual, 2-Wire Hall-Effect Sensor Interface with Diagnostics

MAX9921

## DC ELECTRICAL CHARACTERISTICS (continued)

( $V_{BAT} = 13.6V$ ,  $V_{DIAG} = 0V$ ,  $V_{OE} = 5V$ ,  $IN1 = IN2 =$  no connection,  $R_{ISET} = 63.4k\Omega$ ,  $R_{PU} = 10k\Omega$  at  $\overline{ERR}$ ,  $OUT1$  and  $OUT2$ ,  $T_A = -40^\circ C$  to  $+125^\circ C$ , unless otherwise noted. Typical values are at  $T_A = +25^\circ C$ .) (Note 1)

PARAMETER	SYMBOL	CONDITIONS	MIN	TYP	MAX	UNITS
<b>LOGIC I/O (OUT1, OUT2, <math>\overline{ERR}</math>, DIAG, and OE)</b>						
Output Voltage Low ( $\overline{ERR}$ , $OUT1$ , $OUT2$ )	$V_{OL}$	Sink current = 1mA			0.4	V
Three-State Output Current ( $\overline{ERR}$ , $OUT1$ , $OUT2$ )	$I_{OZ}$	$V_{OE} = 0V$ , $0 \leq V_{OUT\_} \leq 5V$			$\pm 1$	$\mu A$
Input-Voltage High (DIAG, OE)	$V_{IH}$		2.1			V
Input-Voltage Low (DIAG, OE)	$V_{IL}$				0.8	V
Input Resistance to GND (DIAG, OE)	$R_{IN}$		50	80		$k\Omega$

## AC TIMING CHARACTERISTICS

( $V_{BAT} = 13.6V$ ,  $V_{DIAG} = 0V$ ,  $V_{OE} = 5V$ ,  $IN1 = IN2 =$  no connection,  $R_{ISET} = 63.4k\Omega$ ,  $R_{PU} = 10k\Omega$  at  $\overline{ERR}$ ,  $OUT1$  and  $OUT2$ ,  $T_A = -40^\circ C$  to  $+125^\circ C$ , unless otherwise noted. Typical values are at  $T_A = +25^\circ C$ .) (Notes 1 and 2)

PARAMETER	SYMBOL	CONDITIONS	MIN	TYP	MAX	UNITS
$IN1$ , $IN2$ Blanking Time at Hall Switch Power-Up	$t_{BL}$	$I_{IH} = -11.5mA$ to GND, time from $V_{IN\_} = 500mV$ until $OUT\_$ high, $C_L = 20pF$ (Note 3)	50		140	$\mu s$
$IN1$ , $IN2$ Current Ramp Rate After Turn-On	$t_{RAMP}$	$V_{IN} = GND$		3.8		$mA/\mu s$
Delay from $IN\_$ to $OUT\_$ (Filter Delay)	$t_{DEL}$	From $I_{IH}$ to $I_{IL}$ or from $I_{IL}$ to $I_{IH}$ , $C_L = 20pF$ , Figure 1		6.5		$\mu s$
Delay from $IN\_$ Fault to $\overline{ERR}$	$t_{ERR}$	From $I_{IL}$ to $I_{sc}$ or from $I_{IH}$ to $I_{oc}$ , falling edge only, $C_L = 20pF$ , Figure 1		31		ns
Delay from DIAG High to $OUT\_$ and $\overline{ERR}$	$t_{DLH}$	Rising edge of DIAG to falling or rising edge of outputs, $C_L = 20pF$ , Figure 1		350		ns
Delay from DIAG Low to $OUT\_$ and $\overline{ERR}$	$t_{DHL}$	Falling edge of DIAG to falling or rising edge of outputs, $C_L = 20pF$ , Figure 1		1.6		$\mu s$
Delay Difference Between Rising and Falling Edges for Both Channels	$t_{DM}$	$CHALL-BYPASS = 0.01\mu F$ , $I_{IH} = -11.5mA$ and $I_{IL} = -7.2mA$ , $C_L = 20pF$		20		ns
Delay Difference Between Channels	$t_{CC}$	$CHALL-BYPASS = 0.01\mu F$ , $I_{IH} = -11.5mA$ and $I_{IL} = -7.2mA$ , $C_L = 20pF$		100		ns
Maximum Frequency on Hall Inputs	$f_{MAX}$	$CHALL-BYPASS = 0.01\mu F$ , $I_{IH} = -11.5mA$ and $I_{IL} = -7.2mA$ , $C_L = 20pF$	50			$kHz$
$IN\_$ Pulse Length Rejected by Filter to $OUT\_$	$P_R$	Figure 2		5.5		$\mu s$

**Note 1:** All DC specifications are 100% tested at  $T_A = +25^\circ C$ . AC specifications and specifications over  $-40^\circ C$  to  $+125^\circ C$  are guaranteed by design.

**Note 2:**  $C_L$  is external load capacitance on the outputs for test only.

**Note 3:** These blanking times apply when the MAX9921 is operating in normal mode. Blanking times following power-up or startup from shutdown mode are  $20\mu s$  longer.

# Dual, 2-Wire Hall-Effect Sensor Interface with Diagnostics

## Timing Diagrams

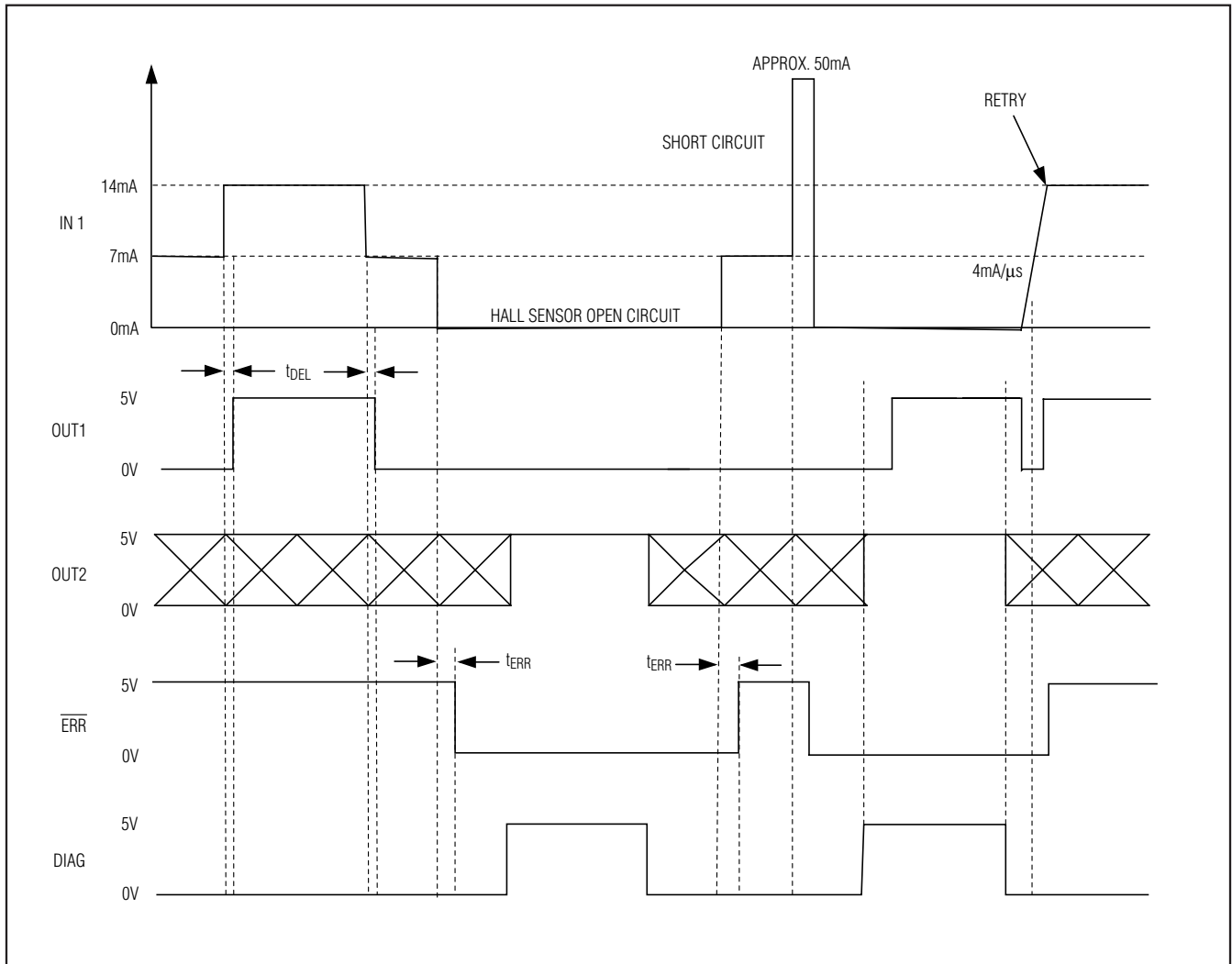

Figure 1. Timing Diagram

# Dual, 2-Wire Hall-Effect Sensor Interface with Diagnostics

## Timing Diagrams (continued)

MAX9921

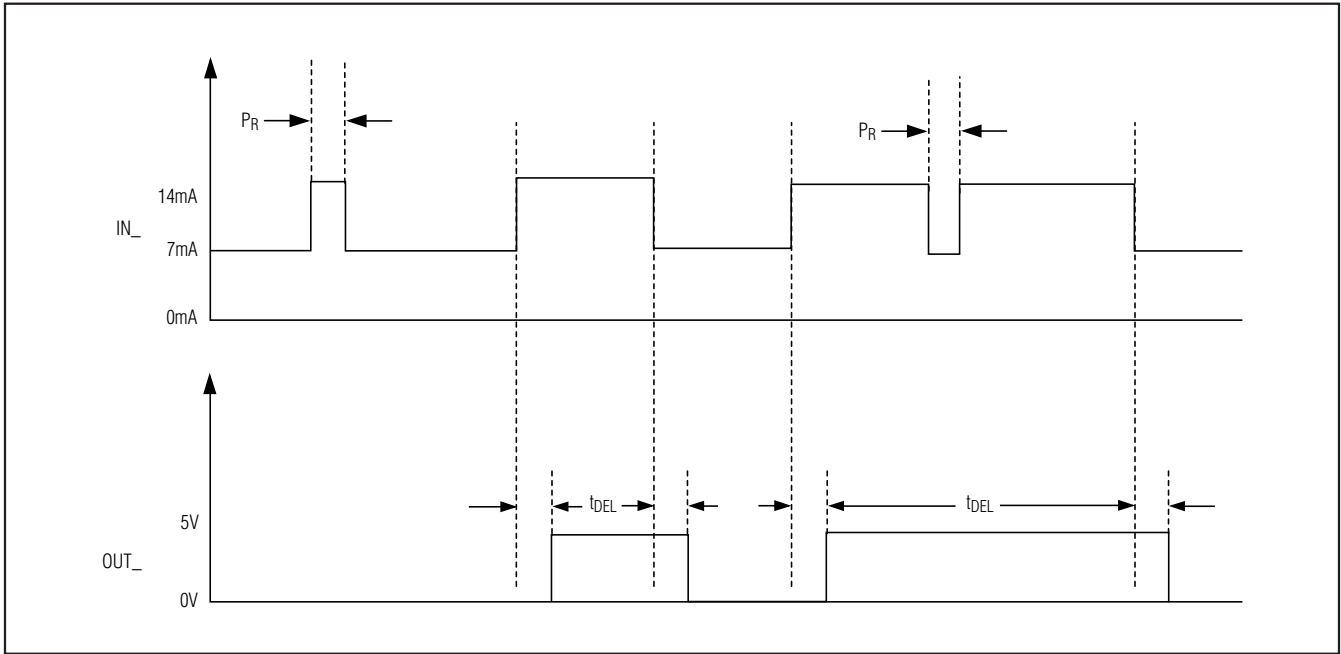
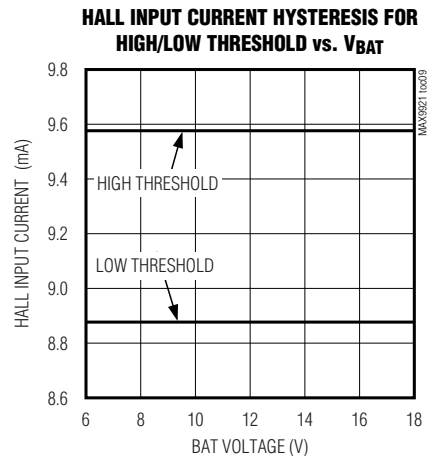
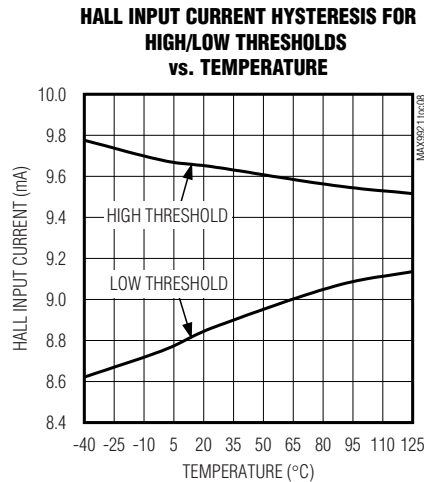
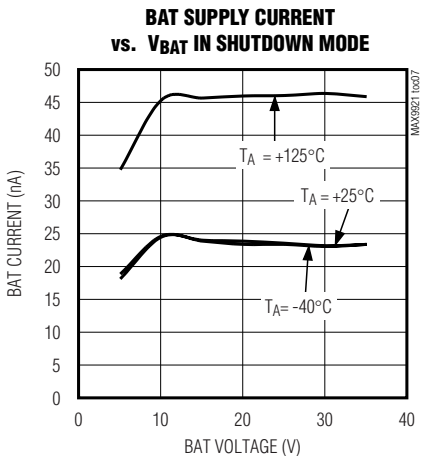
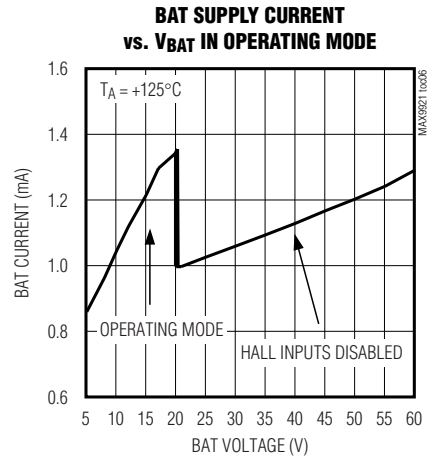
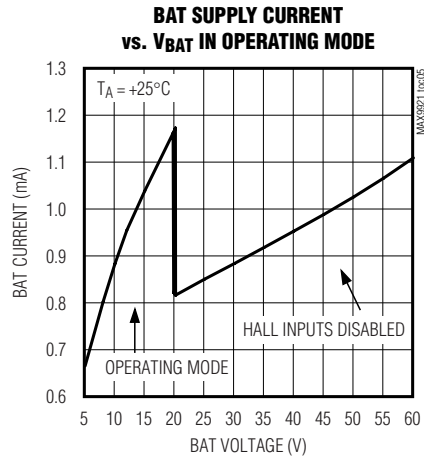
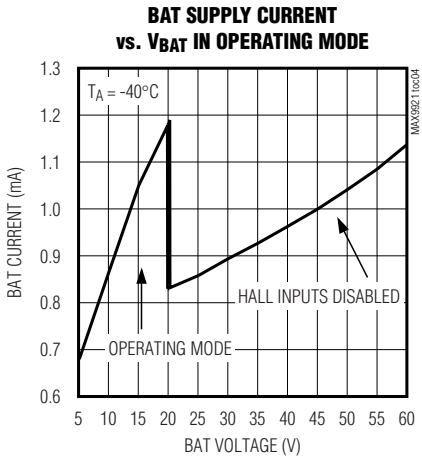
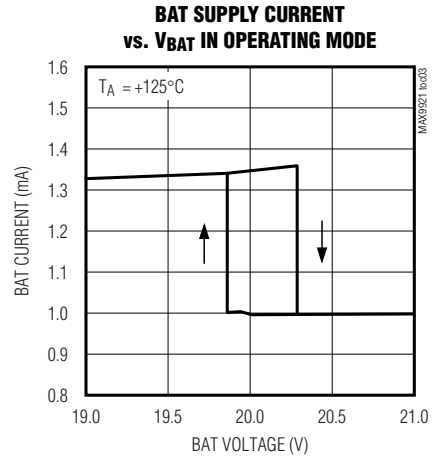
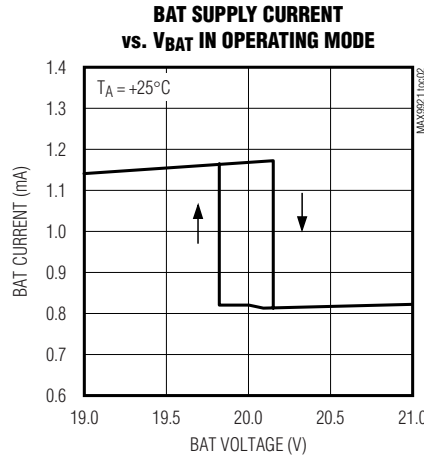
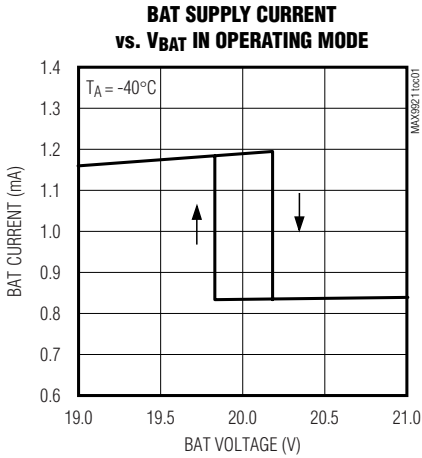

Figure 2. Hall Input Pulse Rejection

# Dual, 2-Wire Hall-Effect Sensor Interface with Diagnostics

## Typical Operating Characteristics

( $V_{BAT} = 14V$ ,  $T_A = +25^\circ C$ , unless otherwise noted.)



# Dual, 2-Wire Hall-Effect Sensor Interface with Diagnostics

MAX9921

## Typical Operating Characteristics (continued)

( $V_{BAT} = 14V$ ,  $T_A = +25^\circ C$ , unless otherwise noted.)

**IN\_ BLANKING TIME AT HALL SWITCH POWER-UP vs. TEMPERATURE**

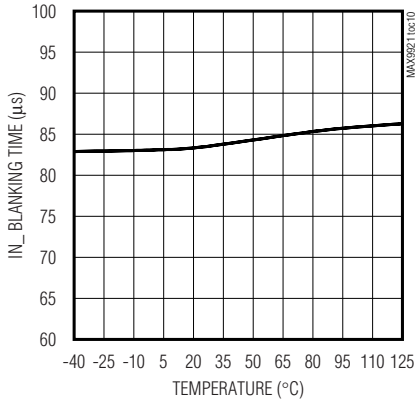

**IN\_ CURRENT RAMP RATE AFTER TURN-ON vs. TEMPERATURE**

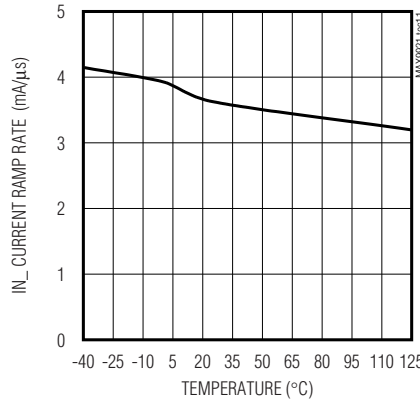

**DELAY FROM IN\_ TO OUT\_ (FILTER DELAY) vs. TEMPERATURE**

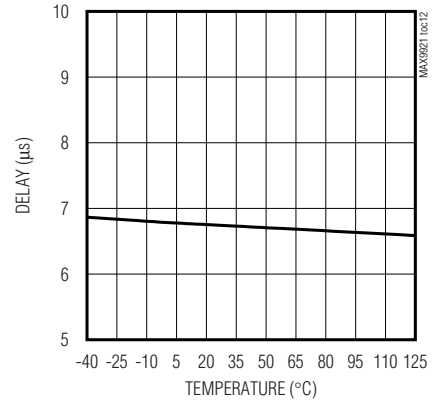

**DELAY FROM IN\_ FAULT TO ERR (FILTER DELAY) vs. TEMPERATURE**

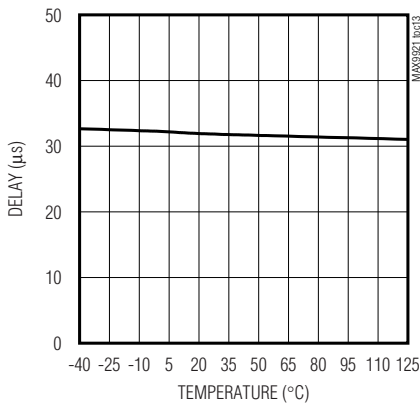

**DELAY DIFFERENCE BETWEEN RISING AND FALLING EDGES FOR BOTH CHANNELS vs. TEMPERATURE**

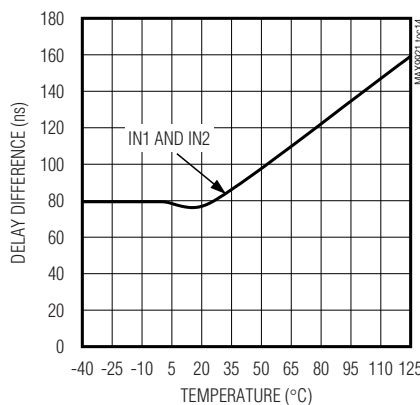

**DELAY DIFFERENCE BETWEEN CHANNELS vs. TEMPERATURE**

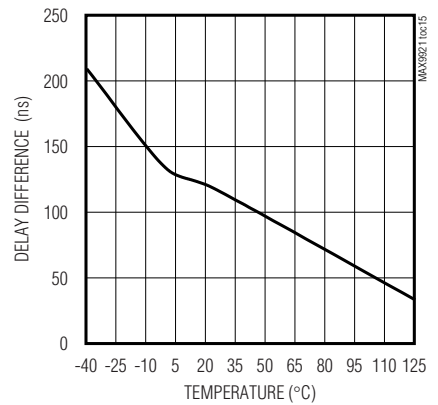

**MAXIMUM FREQUENCY ON HALL INPUTS vs. TEMPERATURE**

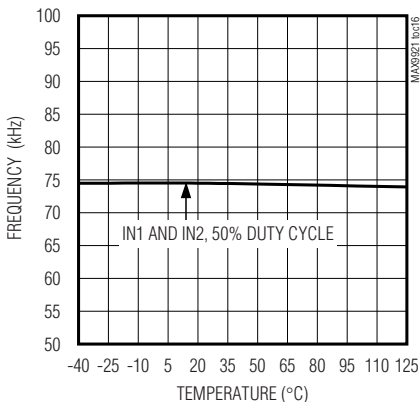

**IN\_ PULSE LENGTH REJECTED BY FILTER TO OUT\_ vs. TEMPERATURE**

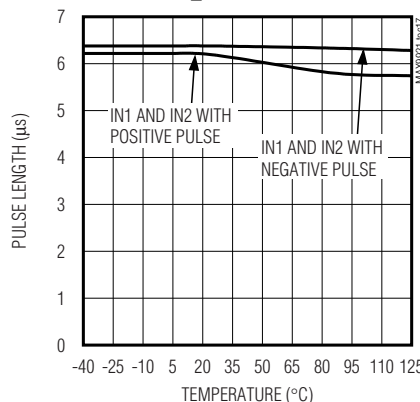

**V<sub>BAT</sub> UNDERVOLTAGE THRESHOLD vs. TEMPERATURE**

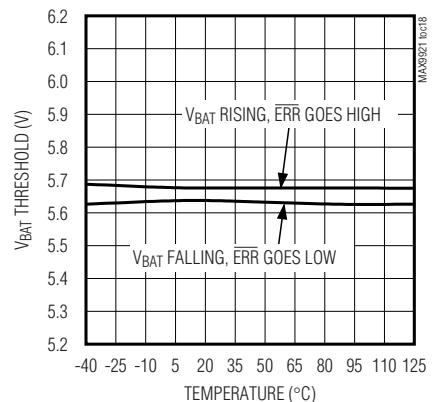

# Dual, 2-Wire Hall-Effect Sensor Interface with Diagnostics

## Typical Operating Characteristics (continued)

( $V_{BAT} = 14V$ ,  $T_A = +25^\circ C$ , unless otherwise noted.)

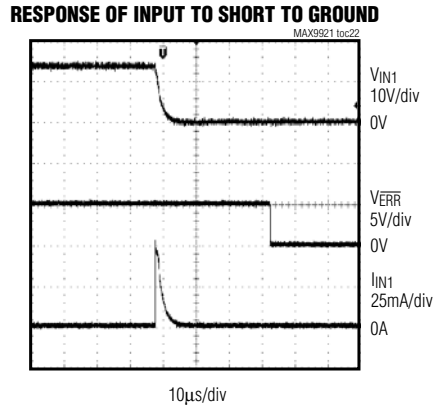
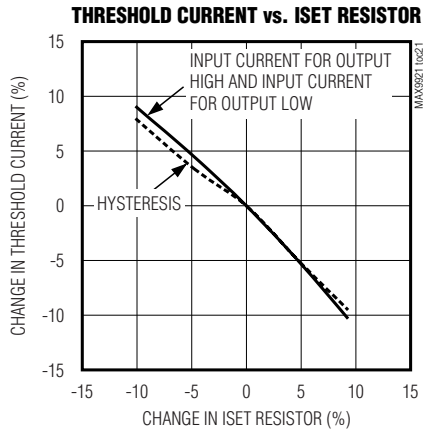
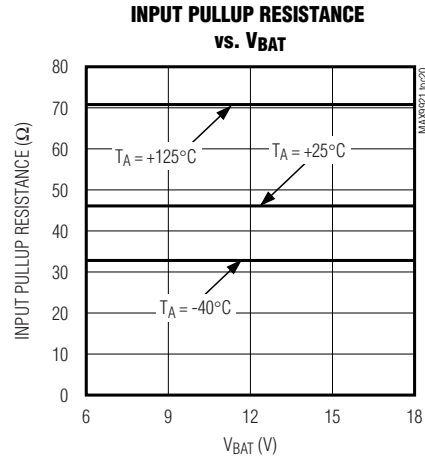
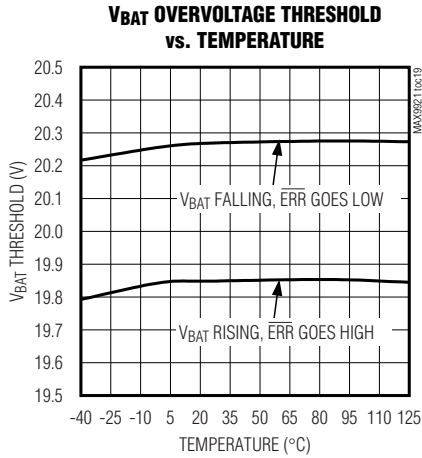

**STARTUP OF HALL INPUT FROM SHUTDOWN**

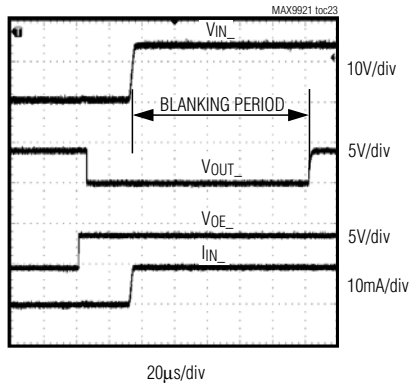

# Dual, 2-Wire Hall-Effect Sensor Interface with Diagnostics

## Pin Description

MAX9921

PIN	NAME	FUNCTION
1	BAT	Battery Power Supply. Connect BAT to the positive supply through an external reverse-polarity diode. Bypass BAT to ground with a 0.1 $\mu$ F capacitor.
2	ISET	Current-Setting Input. Connect a 63.4k $\Omega$ , 1% resistor ( $R_{ISET}$ ) between BAT and ISET to set the standard current thresholds for Hall current sensing. Make no other connections to ISET. All routing must have low parasitic capacitance.
3	IN1	Hall-Effect Sensor Input 1. Bypass IN1 to BAT or GND with a 0.01 $\mu$ F capacitor. Terminate an unused input with a 1.5k $\Omega$ resistor from IN1 to GND to prevent false error diagnostics.
4	IN2	Hall-Effect Sensor Input 2. Bypass IN2 to BAT or GND with a 0.01 $\mu$ F capacitor. Terminate an unused input with a 1.5k $\Omega$ resistor from IN2 to GND to prevent false error diagnostics.
5	GND	Ground
6	OUT2	Open-Drain Output Signal 2. OUT2 is the signal translated from Hall Sensor 2. Connect a 10k $\Omega$ or larger pullup resistor to logic supply.
7	OUT1	Open-Drain Output Signal 1. OUT1 is the signal translated from Hall Sensor 1. Connect a 10k $\Omega$ or larger pullup resistor to logic supply.
8	$\overline{ERR}$	Open-Drain Diagnostic and Error Output. Connect a 10k $\Omega$ or larger pullup resistor to logic supply. If DIAG is asserted low, a high on $\overline{ERR}$ indicates that there is no fault while a low on $\overline{ERR}$ indicates that either the battery voltage is out of range or there is a fault condition. If DIAG is high, $\overline{ERR}$ provides diagnostic information in conjunction with OUT1 and OUT2. See Tables 1 and 2. If OE is low or while in shutdown, $\overline{ERR}$ is high impedance.
9	OE	Output Enable Input. OE has an internal 80k $\Omega$ resistor to GND. Drive OE high to enable the outputs $\overline{ERR}$ , OUT1, and OUT2. Drive OE low to place the outputs in high impedance. If OE and DIAG are both low for more than 40 $\mu$ s, the device enters shutdown and all outputs are in high impedance. While in shutdown, if either OE or DIAG transitions low to high, the device exits shutdown mode.
10	DIAG	Diagnostic Enable Input. DIAG has an internal 80k $\Omega$ resistor to GND. Drive DIAG low for normal operation. In this mode, $\overline{ERR}$ , OUT1, and OUT2 provide Hall sensor information. Drive DIAG high for diagnostic operation. A high-to-low transition initiates an attempt to restart, with a blanking cycle any Hall input that has been shut down. See Tables 1 and 2 (diagnostic truth tables). If OE and DIAG are both low for more than 40 $\mu$ s, the device enters shutdown mode with all outputs in high impedance. While in the shutdown mode, if either OE or DIAG transitions low to high, the device exits shutdown mode.

# Dual, 2-Wire Hall-Effect Sensor Interface with Diagnostics

## Functional Diagram

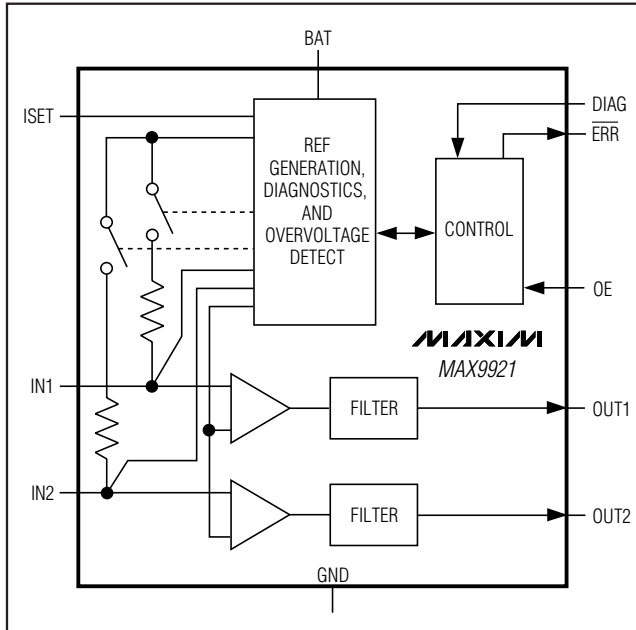

## Detailed Description

The MAX9921 connects two 2-wire Hall-effect sensors to a low-voltage  $\mu\text{P}$ . This device supplies current through IN1 and IN2 to Hall sensors and monitors the current level drawn by the Hall sensors. The MAX9921 outputs a high or low logic-level to the corresponding open-drain output (OUT1 or OUT2). If the current flowing out of either IN1 or IN2 exceeds the high input current threshold, the corresponding output goes high. If the current flowing out of either IN1 or IN2 is lower than the low input current threshold, the corresponding output goes low.

## Hall Input Diagnostic

### Normal Mode

In normal mode, DIAG is driven low. In this case, if  $\overline{\text{ERR}}$  is high, the outputs (OUT1 and OUT2) indicate the high or low state of the corresponding Hall sensors (IN1 and IN2). In normal mode, a low  $\overline{\text{ERR}}$  indicates a fault. If  $\overline{\text{ERR}}$  is low, the outputs may be pulled low and may not indicate the high or low state of the Hall sensors. This can happen during the power-up, restart, or blanking cycles of the Hall inputs, or due to a fault on one or both of the Hall inputs, or when  $V_{\text{BAT}}$  is out of range, while the error output is low. If one output continues signaling and the other output is low, the output with the low logic-level indicates a fault or a restart and blanking cycle on the corresponding Hall input. Table 1 summarizes normal mode operation.

### Diagnostic Mode

When DIAG is driven high, the MAX9921 enters diagnostic mode. In this mode, OUT1 and OUT2 output diagnostic information. IN1 takes precedence over IN2. IN2's diagnostics remain masked until a fault on IN1 is cleared. For diagnostics and troubleshooting, when IN1 or IN2 shuts off due to an input short to ground, it continues to source  $50\mu\text{A}$ . A falling edge at DIAG restarts a Hall input that has been shut off due to a short to ground.

Diagnostic indications are never latched internally and they indicate the real-time state of IN1 or IN2. Table 2 summarizes diagnostic mode operation.

### Hall Input Fault Detection

If a fault is detected, the ERR output is asserted low to notify the  $\mu\text{P}$ . This condition can occur due to the Hall input being shorted to ground, shorted to battery, or open.

**Table 1. Diagnostic Truth Table (Normal Mode)**

INPUT		OUTPUT		DIAGNOSIS	COMMENT
DIAG	$\overline{\text{ERR}}$	OUT1	OUT2		
0	1	0 or 1	0 or 1	OUT1 and OUT2 indicate state of IN1 and IN2, respectively	Normal mode: No fault indication (outputs indicate Hall sensor high or low status)
0	0	0	0	Fault on IN1 and/or IN2, or $V_{\text{BAT}}$ out of range, or power-up or restart blanking (unknown current level of IN1 and IN2)	Normal mode: $\overline{\text{ERR}}$ asserted low indicates fault (outputs may no longer indicate the high or low state of the Hall sensors)
0	0	0	0 or 1	Fault on IN1 or restart blanking of IN1	Normal mode: $\overline{\text{ERR}}$ asserted low indicates fault; Hall output 2 continues signaling
0	0	0 or 1	0	Fault on IN2 or restart blanking of IN2	Normal mode: $\overline{\text{ERR}}$ asserted low indicates fault; Hall output 1 continues signaling

# Dual, 2-Wire Hall-Effect Sensor Interface with Diagnostics

MAX9921

Table 2. Diagnostic Truth Table (Diagnostic Mode)

INPUT		OUTPUT			DIAGNOSIS
DIAG	$\overline{\text{ERR}}$	OUT1	OUT2		
1	0	0	0	No fault	
1	0	0	1	IN1 open circuit, or IN1 open circuit and fault on IN2	
1	0	1	0	IN1 shorted to battery, or IN1 shorted to battery and fault on IN2	
1	0	1	1	IN1 shorted to ground, or IN1 shorted to ground and fault on IN2	
1	1	0	0	V <sub>BAT</sub> out of range, or power-up or restart and blanking cycle (dominant fault masks all other faults)	
1	1	0	1	IN2 open circuit	
1	1	1	0	IN2 shorted to battery	
1	1	1	1	IN2 shorted to ground	

### Hall Sensor Protection from Supply Transients

If the V<sub>BAT</sub> voltage is lower than 6V or exceeds 18V, IN1 and IN2 shut off current to both Hall sensors and  $\overline{\text{ERR}}$ , OUT1, and OUT2 go low. When V<sub>BAT</sub> returns to the proper range, both IN1 and IN2 restart, following a blanking cycle.

### Hall Inputs Open Condition

If either IN1 or IN2 is open (I<sub>IN</sub> < 2mA), the corresponding input shuts off current to the Hall sensor. If IN1 or IN2 is loaded, it exits the open input fault condition and restarts the corresponding Hall input, following a blanking cycle.

### Hall Input Shorted to Battery

If either IN1 or IN2 is shorted to the battery (V<sub>IN</sub> > V<sub>BAT</sub> + 100mV), the MAX9921 shuts off current to the corresponding Hall sensor. In this case, if IN1 or IN2 is more than 1V above V<sub>BAT</sub>, it may back-drive current into BAT. In such a condition, the current level in the Hall input should not exceed 100mA. Therefore, all the MAX9921s together can share a separate reverse-polarity protection diode to avoid powering up other circuitry sharing a common diode (Figure 3).

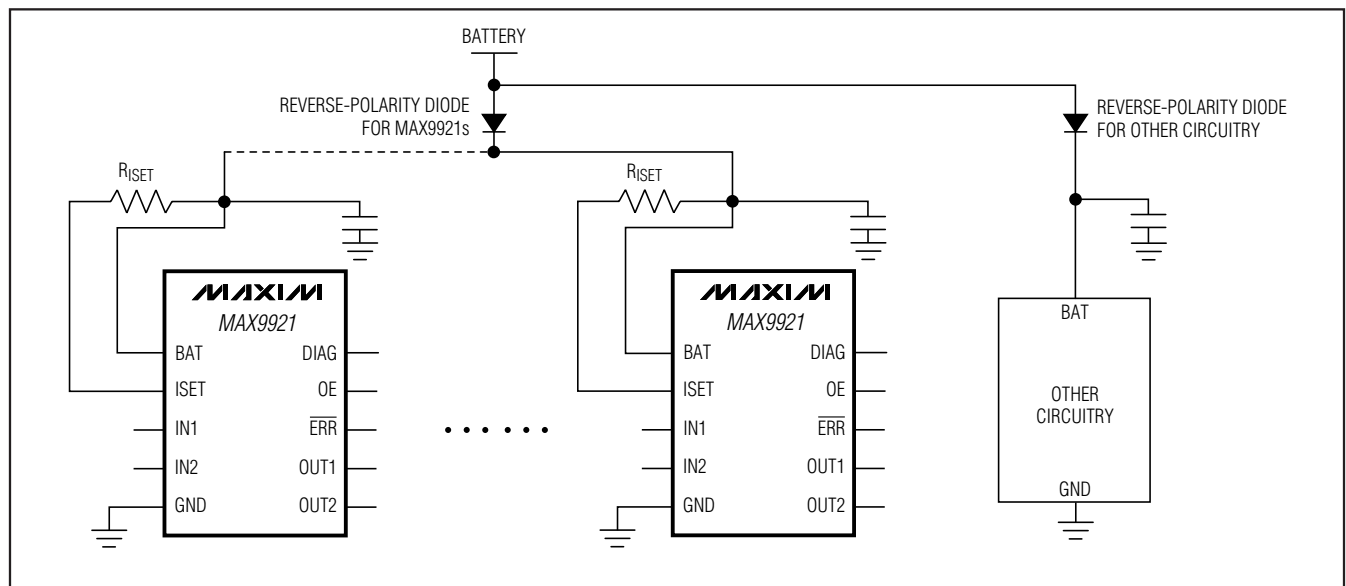

Figure 3. Several MAX9921s Connected to a Common Reverse-Polarity Diode

## Dual, 2-Wire Hall-Effect Sensor Interface with Diagnostics

### Hall Input Short-to-Ground

The Hall input shorted-to-ground fault is effectively a latched condition if the input remains loaded by the Hall switch when the shorting condition is removed. The current required to power the Hall switch is shut off and only a 50 $\mu$ A pullup current remains. The Hall input can be manually re-energized or it can be re-energized by the ECU. A falling edge at DIAG initiates a restart with a blanking cycle of any Hall input that has been shut down due to the shorted-to-ground condition. During startup or restart, it is possible for a Hall input to charge up an external capacitance of 0.02 $\mu$ F without tripping into a shorted-to-ground latched state. All other fault conditions are not latched and when these other faults are removed, ERR goes high and the Hall input is again functional.

### Manual Method for Re-Energizing Hall Sensor and Means for Diagnosing an Intermittent Hall Sensor Connection

Figure 4 shows the behavior of the MAX9921 when a Hall input is open. Figure 5 shows the behavior of the MAX9921 when the open input is reconnected to a Hall sensor. Figures 4 and 5 demonstrate how a shorted-to-ground Hall input can be reset.

Resetting a shorted-to-ground Hall input involves three steps:

- 1) Relieve the short to ground at the Hall sensor.
- 2) Disconnect the Hall input from the Hall sensor (open input fault condition).
- 3) Reconnect the Hall input to the Hall sensor.

The MAX9921 restarts the Hall input with a blanking cycle. If the Hall input is disconnected from the Hall sensor for 10ms, it allows the Hall input to be pulled up by the 50 $\mu$ A pullup current to register the open-input fault condition. Then, reconnecting the Hall input to the Hall sensor restarts the Hall input with a blanking cycle. This provides a manual means of re-energizing a Hall input without having to resort to the ECU to reset it. This also demonstrates that an intermittent connection to a Hall sensor can recover without intervention of the ECU. This gives the ECU a means of diagnosing an intermittent connection to a Hall sensor by using the diagnostic mode to detect a diagnostic sequence of "open-circuit" to "blanking cycle" to "no fault."

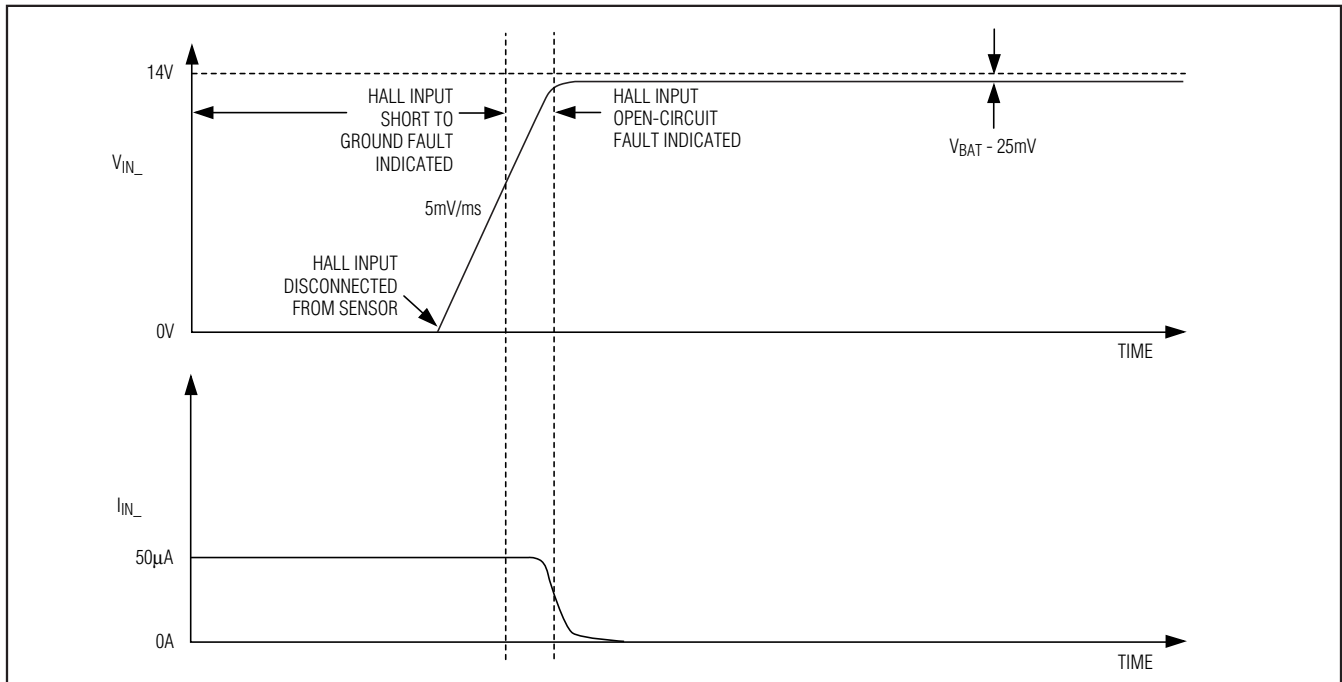

Figure 4. Hall Input Ramps to Open-Circuit Fault When Short to Ground is Relieved

# Dual, 2-Wire Hall-Effect Sensor Interface with Diagnostics

MAX9921

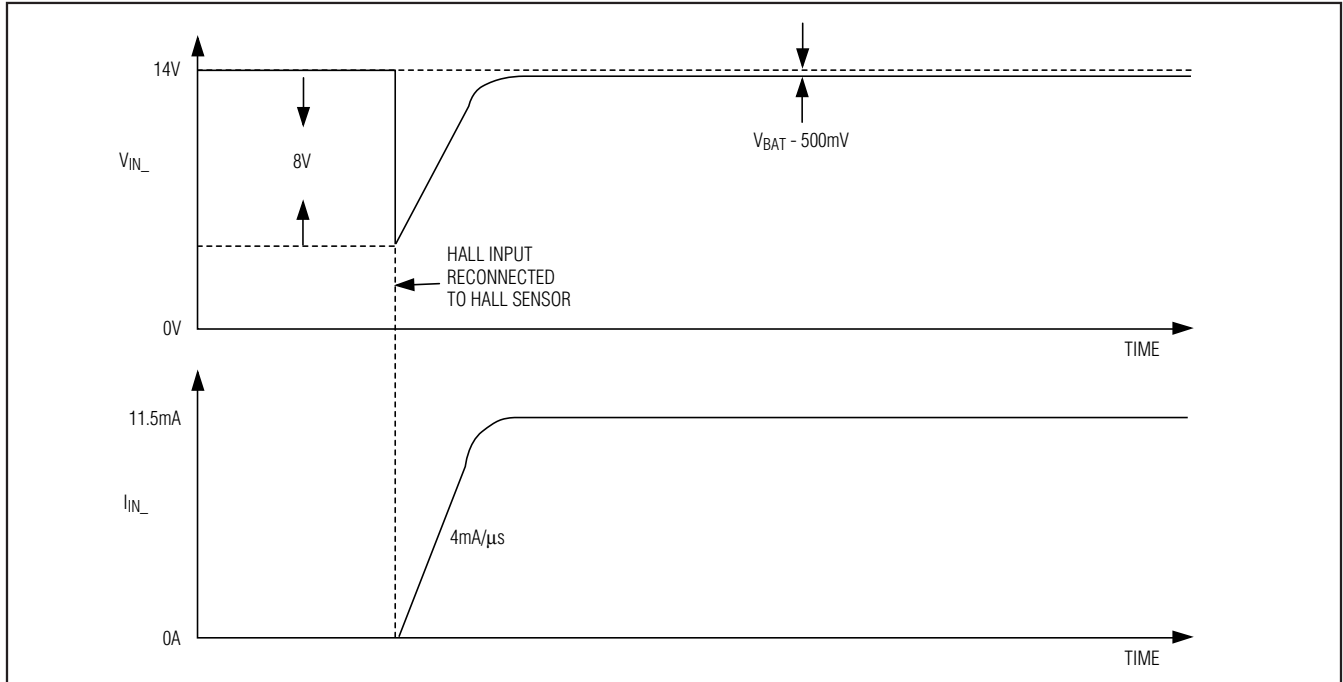

Figure 5. Hall Input Re-Energized When Open Input is Reconnected to Hall Sensor

**Table 3. Summary of Fault Protection and Recovery**

FAULT DESCRIPTION	CRITERION	MAX9921 ACTIONS		COMMENT/RECOVERY
		$\overline{\text{ERR}}$ OUTPUT	HALL INPUT RESPONSE	
$V_{\text{BAT}} < 6\text{V}$	—	Asserted low	Shutoff current to both Hall sensors	Both IN1 and IN2 are restarted with blanking cycle when $V_{\text{BAT}}$ returns to proper range.
$V_{\text{BAT}} > 18\text{V}$	—	Asserted low	Shutoff current to both Hall sensors	Both IN1 and IN2 are restarted with blanking cycle when $V_{\text{BAT}}$ returns to proper range.
Hall input open	$I_{\text{IN}} < 2\text{mA}$	Asserted low	Shutoff current to corresponding Hall sensor	When a Hall input is again loaded, terminating open input condition, the Hall input are restarted with blanking cycle.
Hall input shorted to battery	$V_{\text{IN}} > V_{\text{BAT}}$ due to external reverse-battery protection diode	Asserted low	Shutoff current to corresponding Hall sensor	If a Hall input is pulled more than 1V above $V_{\text{BAT}}$ , the input may back drive current into the BAT supply and pull $V_{\text{BAT}}$ up with it. In this condition, current levels in the Hall inputs should never exceed 100mA. For this reason, it is recommended that one or more MAX9921s be powered together and share a reverse-polarity diode separate from other circuitry.
Hall input shorted to ground	$I_{\text{IN}} > 23\text{mA}$	Asserted low	Shutoff current to corresponding Hall sensor. $50\mu\text{A}$ of pullup current is sourced to IN1 or IN2 to aid in troubleshooting.	A falling edge at DIAG initiates a restart with a blanking cycle of any Hall input that has been shut off due to a short to ground. See the <i>Hall Input Short-to-Ground</i> section.

# Dual, 2-Wire Hall-Effect Sensor Interface with Diagnostics

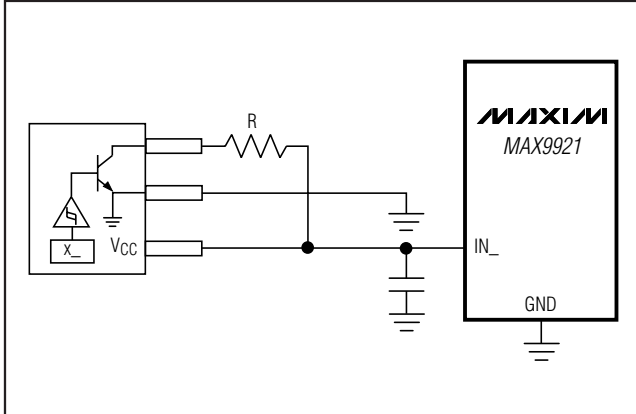

Figure 6. 3-Wire Hall-Effect Switches Configured as 2-Wire

## Applications Information

### Hall-Effect Sensor Selection

The MAX9921 is optimized for use with 2-wire Hall-effect switches or with 3-wire Hall-effect switches connected as 2-wire (Figure 6). When using a 3-wire Hall sensor, the resistor R is chosen so that the current drawn by the Hall sensor crosses the MAX9921 current threshold when the magnetic threshold of the Hall sensor is exceeded.

Table 4 shows a partial list of mostly 2-wire Hall switches, which can be used with the MAX9921.

Table 4. Partial List of Compatible Hall Switches

PART	MANUFACTURER	WEBSITE	COMMENT
HAL573-6	Micronas	www.micronas.com	2-wire
HAL556/560/566	Micronas	www.micronas.com	2-wire
HAL581/584	Micronas	www.micronas.com	2-wire
A1140/1/2/3	Allegro	www.allegromicro.com	2-wire
3161	Allegro	www.allegromicro.com	3-wire, optimized for 2-wire use without added resistor
TLE4941/C	Infineon	www.infineon.com	2-wire

### Hall Input Bypass Capacitor

The MAX9921 is optimized for use with external protection 0.01 $\mu$ F capacitors from both IN1 and IN2 to BAT. These are essential to ensure robustness against automotive transients. These capacitors may be tied to GND instead of to BAT, but the connection to BAT is recommended.

### Low-Voltage Operation

To ensure correct operation of the Hall sensor at low input voltages, it is important to consider the voltage drop of the MAX9921 with low battery voltages. This dropout voltage can be calculated using the formula:

$$V_{\text{DROPOUT}} = I_{\text{HALL}} \times R_{\text{PU}}$$

$I_{\text{HALL}}$  is the maximum current which must be supplied to the Hall sensor and  $R_{\text{PU}}$  is the internal resistance of the MAX9921, nominally 50 $\Omega$  (see the Input Pullup Resistance vs.  $V_{\text{BAT}}$  graph in the *Typical Operating Characteristics*). As an example, assume the use of a HAL573 sensor, which draws a maximum current of 17mA. The dropout voltage is then 850mV and the approximate minimum voltage supplied to the Hall sensor is 6V - 0.85V = 5.15V, which is higher than the minimum operating voltage of 3.75V specified for the HAL573.

# Dual, 2-Wire Hall-Effect Sensor Interface with Diagnostics

**MAX9921**

## Pin Configuration

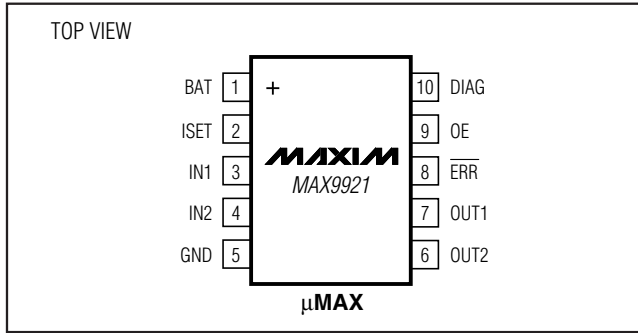

## Chip Information

PROCESS: BiCMOS

## Package Information

For the latest package outline information and land patterns, go to [www.maxim-ic.com/packages](http://www.maxim-ic.com/packages).

PACKAGE TYPE	PACKAGE CODE	DOCUMENT NO.
10 μMAX	U10+2	<a href="#">21-0061</a>

Maxim cannot assume responsibility for use of any circuitry other than circuitry entirely embodied in a Maxim product. No circuit patent licenses are implied. Maxim reserves the right to change the circuitry and specifications without notice at any time.

Maxim Integrated Products, 120 San Gabriel Drive, Sunnyvale, CA 94086 408-737-7600 \_\_\_\_\_ 15