



MAX8902 Evaluation Kit

General Description

The MAX8902 evaluation kit (EV kit) is a fully assembled and tested printed-circuit board (PCB) for evaluating the MAX8902A low-dropout linear regulator (LDO). The EV kit operates from a 1.7V to 5.5V supply and provides a jumper-selectable output voltage of 1.5V, 1.8V, 2.0V, 2.5V, 3.0V, 3.1V, 3.3V, 4.6V, or 4.7V, with loads up to 500mA. The MAX8902 EV kit comes with the MAX8902A installed, but can also be used to evaluate the MAX8902B with an adjustable output voltage from 0.6V to 5.3V.

Component List

DESIGNATION	QTY	DESCRIPTION
C1*, C3	2	10 μ F \pm 10%, 6.3V X5R ceramic capacitors (0805) TDK C2012X5R0J106K Murata GRM21BR60J106K
C2	1	0.01 μ F \pm 10%, 25V X7R ceramic capacitor (0402) TDK C1005X7R1E103K
C4	0	Not installed, capacitor (0805)
C5	0	Not installed, capacitor (0402)
JU1, JU2, JU3	3	3-pin headers, 0.1in
R1	1	0 Ω resistor (0402)
R2, R3	0	Not installed, resistors (0402)
U1	1	Low dropout linear regulator (8-pin TDFN-EP**, 2mm x 2mm x 0.8mm) Maxim MAX8902AATA+
—	3	Shunts, 2 position
—	1	PCB: MAX8902 Evaluation Kit+

*Due to the poor voltage coefficient of small case sizes, if the device is operating in dropout, a 1206 size capacitor is recommended for C1.

**EP = Exposed paddle.

Component Suppliers

SUPPLIER	PHONE	WEBSITE
Murata Mfg. Co., Ltd.	814-237-1431	www.murata.com
TDK Corp.	847-803-6100	www.component.tdk.com

Note: Indicate that you are using the MAX8902A or MAX8902B when contacting these component suppliers.

Features

- ◆ 1.7V to 5.5V Input-Voltage Range
- ◆ Guaranteed 500mA Output Current
- ◆ \pm 1.5% Output Accuracy over Load/Line/Temperature
- ◆ 100mV (max) Drop Out at 500mA Load
- ◆ < 1 μ A Shutdown Supply Current
- ◆ 700mA Short-Circuit Protection
- ◆ Reverse-Current Protection
- ◆ Thermal-Overload Protection
- ◆ 2mm x 2mm x 0.8mm TDFN IC Package
- ◆ Fully Assembled and Tested

Ordering Information

PART	TYPE
MAX8902EVKIT+	EV Kit

+Denotes lead-free and RoHS-compliant.

Quick Start

Recommended Equipment

Before beginning, the following equipment is needed:

- 1.7V to 5.5V power supply or battery able to deliver 1A
- Voltmeter
- Load (up to 500mA)

Procedure

The MAX8902 EV kit is fully assembled and tested. Follow the steps below to verify board operation:

- 1) Preset the power supply to between 1.7V and 5.5V.
- 2) Turn off the power supply. **Caution: Do not turn on the power supply until all connections are completed.**
- 3) Place the shunt of JU1 across pins 2-3 to enable the MAX8902A.
- 4) Select the output voltage using jumpers JU2 and JU3 (see Table 2).
- 5) Connect the positive power-supply lead to the IN pad of the EV kit.
- 6) Connect the power-supply ground to the GND pad next to IN.
- 7) Connect the voltmeter and load from the EV kit OUT pad to the GND pad next to OUT.
- 8) Turn on the power supply.
- 9) Verify that the output voltage matches the values as shown in Table 2.

Evaluates: MAX8902A/MAX8902B

MAX8902 Evaluation Kit

Detailed Description

The MAX8902 evaluation kit (EV kit) is a fully assembled and tested PCB for evaluating the MAX8902A low-dropout linear regulator (LDO). The EV kit operates from a 1.7V to 5.5V supply and provides a jumper-selectable output voltage of 1.5V, 1.8V, 2.0V, 2.5V, 3.0V, 3.1V, 3.3V, 4.6V, or 4.7V, with loads up to 500mA. The output-voltage setting set by jumpers JU2 and JU3 is fixed at startup. Changing these jumpers while the IC is operating has no effect. The MAX8902 EV kit comes with the MAX8902A installed, but can also be used to evaluate the MAX8902B.

Evaluating the MAX8902B

To evaluate the MAX8902B, carefully remove the IC (U1) and replace it with the MAX8902B. Remove the shunts from jumpers JU2 and JU3. Remove the 0Ω resistor from R1 and install R1 and R2 to set the desired output voltage.

Setting the MAX8902B Output Voltage

The MAX8902B uses external feedback resistors to set the output regulation voltage. The output can be set from 0.6V to 5.3V. Set the lower feedback resistor (R2) to ≤ 120kΩ to minimize FB input bias current error. Then calculate the value of the upper feedback resistor (R1) as follows:

$$R1 = R2 \times \left(\frac{V_{OUT}}{V_{FB}} - 1 \right)$$

Table 1. JU1 Settings (MAX8902A and MAX8902B)

1-2	2-3
Shutdown	Enable

where V_{FB} is the feedback regulation voltage of 0.6V. When setting the output to 0.6V, short R1 and leave R2 open.

POK Output (MAX8902B)

The MAX8902B has an open-drain power-OK output (POK). POK pulls low to indicate that the output voltage is in regulation. During startup, POK is high impedance until the output voltage rises to 90% of its regulation level. If an overload occurs at the output, or the output is shut down, POK is high impedance. To use POK as a logic-level output, install pullup resistor R3.

Enable

Jumper JU1 is provided to enable or disable the IC by connecting EN to IN or GND. If an external enable signal is used, remove the shunt from JU1 and connect the external signal to pin 2 of JU1. Ensure that the signal does not exceed 5.5V.

Table 2. JU2 and JU3 Settings (MAX8902A Only)

OUTPUT VOLTAGE (V)	JU2	JU3
1.5	2-3	Open
1.8	Open	1-2
2.0	Open	2-3
2.5	Open	Open
3.0	1-2	1-2
3.1	1-2	2-3
3.3	1-2	Open
4.6	2-3	1-2
4.7	2-3	2-3

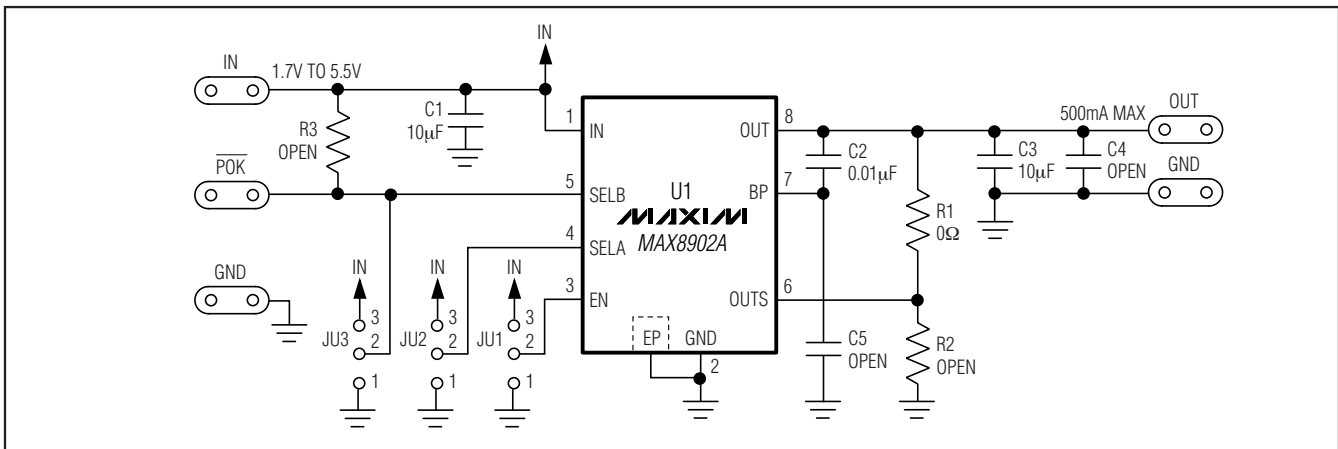

Figure 1. MAX8902 EV Kit Schematic

MAX8902 Evaluation Kit

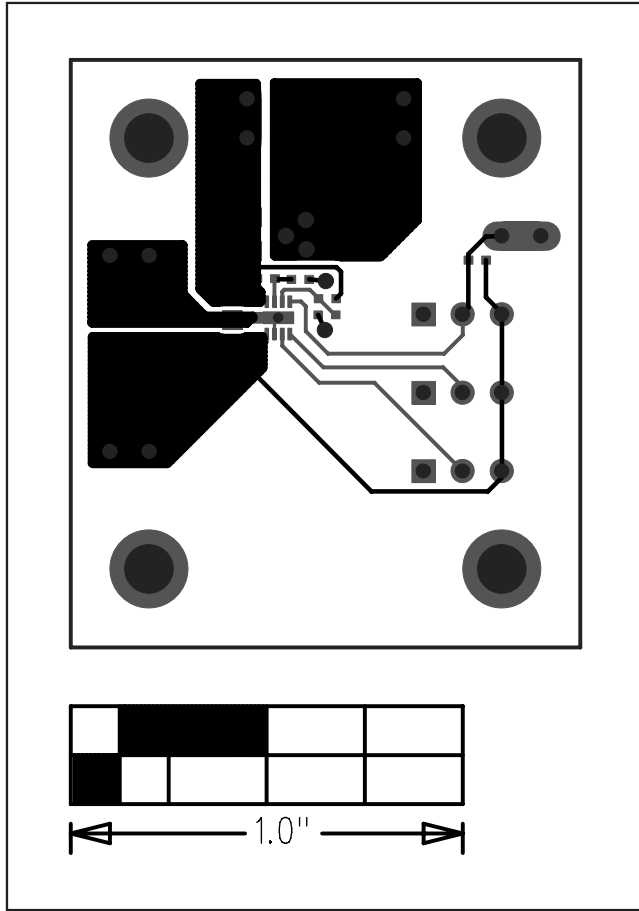

Figure 4. MAX8902 EV Kit PCB Layout—Component Side

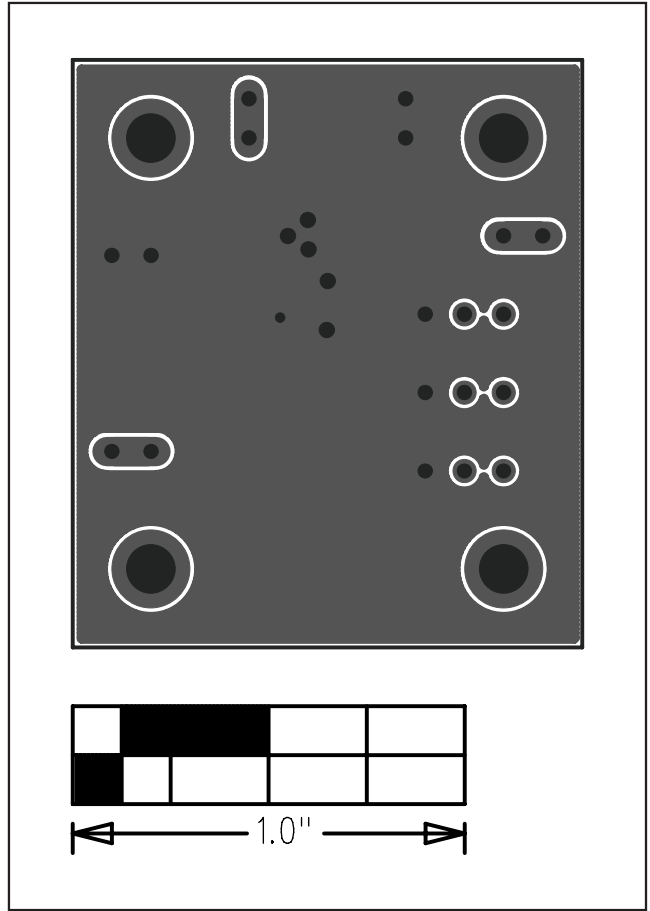

Figure 5. MAX8902 EV Kit PCB Layout—Solder Side

Maxim cannot assume responsibility for use of any circuitry other than circuitry entirely embodied in a Maxim product. No circuit patent licenses are implied. Maxim reserves the right to change the circuitry and specifications without notice at any time.

4 _____ **Maxim Integrated Products, 120 San Gabriel Drive, Sunnyvale, CA 94086 408-737-7600**