



Low-Capacitance, 2/3/4/6-Channel, $\pm 15\text{kV}$ ESD Protection Arrays for High-Speed Data Interfaces

General Description

The MAX3202E/MAX3203E/MAX3204E/MAX3206E are low-capacitance $\pm 15\text{kV}$ ESD-protection diode arrays designed to protect sensitive electronics attached to communication lines. Each channel consists of a pair of diodes that steer ESD current pulses to V_{CC} or GND. The MAX3202E/MAX3203E/MAX3204E/MAX3206E protect against ESD pulses up to $\pm 15\text{kV}$ Human Body Model, $\pm 8\text{kV}$ Contact Discharge, and $\pm 15\text{kV}$ Air-Gap Discharge, as specified in IEC 61000-4-2. These devices have a 5pF capacitance per channel, making them ideal for use on high-speed data I/O interfaces.

The MAX3202E is a two-channel device intended for USB and USB 2.0 applications. The MAX3203E is a triple-ESD structure intended for USB On-the-Go (OTG) and video applications. The MAX3204E is a quad-ESD structure designed for Ethernet and FireWire® applications, and the MAX3206E is a six-channel device designed for cell phone connectors and SVGA video connections.

All devices are available in tiny 4-bump (1.05mm x 1.05mm) UCSP™, 6-bump (1.05mm x 1.57mm) UCSP, 9-bump (1.52mm x 1.52mm) UCSP, 6-pin (3mm x 3mm) TDFN, and 12-pin (4mm x 4mm) TQFN packages and are specified for -40°C to $+85^{\circ}\text{C}$ operation.

Applications

USB	Video
USB 2.0	Cell Phones
Ethernet	SVGA Video Connections
FireWire	

Selector Guide

PART	ESD-PROTECTED I/O PORTS
MAX3202EEBS-T	2
MAX3202EEWS+T	2
MAX3202EETT-T	2
MAX3203EEBT-T	3
MAX3203EETT-T	3
MAX3204EEBT-T	4
MAX3204EETT-T	4
MAX3206EEBL-T	6
MAX3206EETC	6

Pin Configurations appear at end of data sheet.

FireWire is a registered trademark of Apple Computer, Inc.

UCSP is a trademark of Maxim Integrated Products, Inc.



Features

- ◆ High-Speed Data Line ESD Protection
 - $\pm 15\text{kV}$ —Human Body Model
 - $\pm 8\text{kV}$ —IEC 61000-4-2, Contact Discharge
 - $\pm 15\text{kV}$ —IEC 61000-4-2, Air-Gap Discharge
- ◆ Tiny UCSP Package Available
- ◆ Low 5pF Input Capacitance
- ◆ Low 1nA (max) Leakage Current
- ◆ Low 1nA Supply Current
- ◆ +0.9V to +5.5V Supply Voltage Range
- ◆ 2-, 3-, 4-, or 6-Channel Devices Available

Ordering Information

PART	PIN-PACKAGE	TOP MARK	PKG CODE
MAX3202EEBS-T	4-UCSP*	+AFV	B4-2
MAX3202EEWS+T	4-UCSP*	+AA	W41A1-1
MAX3202EETT-T	6-TDFN-EP**	+ADQ	T633-2
MAX3202EEBT-T	6-UCSP*	+ABA	B6-4
MAX3203EETT-T	6-TDFN-EP**	+ADO	T633-2
MAX3204EEBT-T	6-UCSP*	+ABB	B6-3
MAX3204EETT-T	6-TDFN-EP**	+ADP	T633-2
MAX3206EEBL-T	9-UCSP*	+ADU	B9-5
MAX3206EETC	12-TQFN-EP**	+AACA	T1244-4

*UCSP reliability is integrally linked to the user's assembly methods, circuit board material, and environment. Refer to the UCSP Reliability Notice in the UCSP Reliability section for more information.

**EP = Exposed pad.

Note: All devices operate over -40°C to $+85^{\circ}\text{C}$ temperature range.

+ Denotes a lead-free package.

Typical Operating Circuit

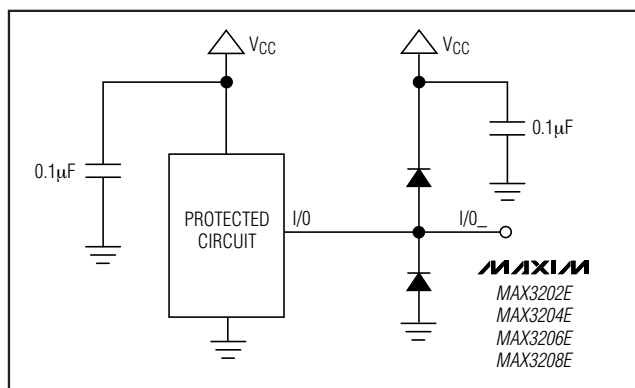

MAX3202E/MAX3203E/MAX3204E/MAX3206E

Low-Capacitance, 2/3/4/6-Channel, ±15kV ESD Protection Arrays for High-Speed Data Interfaces

ABSOLUTE MAXIMUM RATINGS

V _{CC} to GND	-0.3V to +7.0V	Operating Temperature Range	-40°C to +85°C
I/O_ to GND	-0.3V to (V _{CC} + 0.3V)	Storage Temperature Range	-65°C to +150°C
Continuous Power Dissipation (T _A = +70°C)		Junction Temperature	+150°C
2 × 2 UCSP (derate 3.0mW/°C above +70°C)	239mW	Bump Temperature (soldering) (Note 1)	
3 × 2 UCSP (derate 3.4mW/°C above +70°C)	273mW	Infrared (15s)	+220°C
3 × 2 UCSP (derate 3.9mW/°C above +70°C)	308mW	Vapor Phase (60s)	+215°C
3 × 3 UCSP (derate 4.7mW/°C above +70°C)	379mW	Lead Temperature (soldering, 10s)	+300°C
6-Pin TDFN (derate 24.4mW/°C above +70°C)	1951mW		
12-Pin TQFN (derate 16.9mW/°C above +70°C)	1349mW		

Note 1: The UCSP devices are constructed using a unique set of packaging techniques that impose a limit on the thermal profile the device can be exposed to during board-level solder attach and rework. This limit permits the use of only the solder profiles recommended in the industry-standard specification, JEDEC 020A, paragraph 7.6, Table 3 for IR/VPR and Convection Reflow. Preheating is required. Hand or wave soldering is not allowed.

Stresses beyond those listed under "Absolute Maximum Ratings" may cause permanent damage to the device. These are stress ratings only, and functional operation of the device at these or any other conditions beyond those indicated in the operational sections of the specifications is not implied. Exposure to absolute maximum rating conditions for extended periods may affect device reliability.

ELECTRICAL CHARACTERISTICS

(V_{CC} = +5V ±5%, T_A = T_{MIN} to T_{MAX}, unless otherwise noted. Typical values are at V_{CC} = +5V and T_A = +25°C.) (Note 2)

PARAMETER	SYMBOL	CONDITIONS	MIN	TYP	MAX	UNITS
Supply Voltage	V _{CC}		0.9		5.5	V
Supply Current	I _{CC}			1	100	nA
Diode Forward Voltage	V _F	I _F = 10mA	0.65		0.95	V
Channel Clamp Voltage (Note 3)	V _C	T _A = +25°C, ±15kV Human Body Model, I _F = 10A	Positive transients		V _{CC} + 25	V
			Negative transients		-25	
		T _A = +25°C, ±8kV Contact Discharge (IEC 61000-4-2), I _F = 24A	Positive transients		V _{CC} + 60	
			Negative transients		-60	
		T _A = +25°C, ±15kV Air-Gap Discharge (IEC 61000-4-2), I _F = 45A	Positive transients		V _{CC} + 100	
			Negative transients		-100	
Channel Leakage Current		T _A = 0°C to +50°C (Note 4)	-1		+1	nA
Channel Input Capacitance		V _{CC} = 5V, bias of V _{CC} /2		5	7	pF
ESD PROTECTION						
Human Body Model				±15		kV
IEC 61000-4-2 Contact Discharge				±8		kV
IEC 61000-4-2 Air-Gap Discharge				±15		kV

Note 2: Limits over temperature are guaranteed by design, not production tested.

Note 3: Idealized clamp voltages (L1 = L2 = L3 = 0) (Figure 1); see the *Applications Information* section for more information.

Note 4: Guaranteed by design. Not production tested.

Low-Capacitance, 2/3/4/6-Channel, ±15kV ESD Protection Arrays for High-Speed Data Interfaces

Typical Operating Characteristics

($V_{CC} = +5V$, $T_A = +25^\circ C$, unless otherwise noted.)

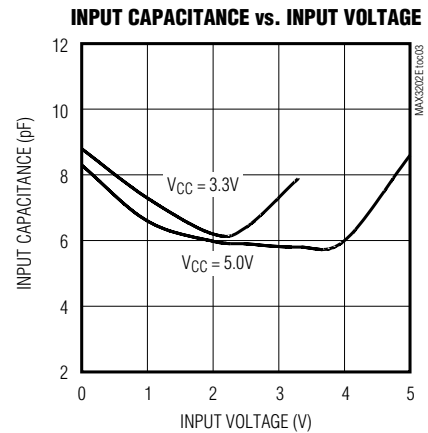
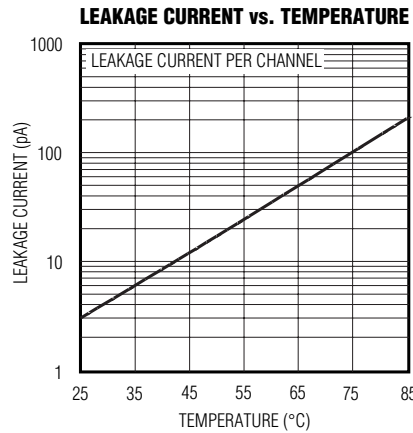
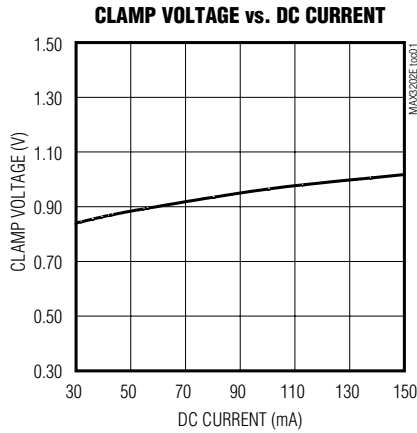

Pin Description

PIN								NAME	FUNCTION
MAX3202E		MAX3203E		MAX3204E		MAX3206E			
UCSP	TDFN-EP	UCSP	TDFN-EP	UCSP	TDFN-EP	UCSP	TQFN-EP		
A1, B2	3, 6	A1, A2, B3	1, 2, 4	A1, A2, B2, B3	1, 2, 4, 5	A1, A3, B1, B3, C1, C3	1, 2, 3, 7, 8, 9	I/O ₋	ESD-Protected Channel
A2	4	B1	3	B1	3	A2	5	GND	Ground
B1	1	A3	6	A3	6	C2	11	V _{CC}	Power-Supply Input. Bypass V _{CC} to GND with a 0.1µF ceramic capacitor.
—	2, 5	—	5	—	—	—	4, 6, 10, 12	N.C.	No Connection. Not internally connected.
—	—	—	—	—	—	—	—	EP	Exposed Pad. Connect to GND.

MAX3202E/MAX3203E/MAX3204E/MAX3206E

Low-Capacitance, 2/3/4/6-Channel, ±15kV ESD Protection Arrays for High-Speed Data Interfaces

Detailed Description

The MAX3202E/MAX3203E/MAX3204E/MAX3206E are diode arrays designed to protect sensitive electronics against damage resulting from ESD conditions or transient voltages. The low input capacitance makes these devices ideal for high-speed data lines. The MAX3202E, MAX3203E, MAX3204E, and MAX3206E protect two, three, four, and six channels, respectively.

The MAX3202E/MAX3203E/MAX3204E/MAX3206E are designed to work in conjunction with a device's intrinsic ESD protection. The MAX3202E/MAX3203E/MAX3204E/MAX3206E limit the excursion of the ESD event to below ±25V peak voltage when subjected to the Human Body Model waveform. When subjected to the IEC 61000-4-2 waveform, the peak voltage is limited to ±60V when subjected to Contact Discharge and ±100V when subjected to Air-Gap Discharge. The device that is being protected by the MAX3202E/MAX3203E/MAX3204E/MAX3206E must be able to withstand these peak voltages plus any additional voltage generated by the parasitic board.

Applications Information

Design Considerations

Maximum protection against ESD damage results from proper board layout (see the *Layout Recommendations* section and Figure 2). A good layout reduces the parasitic series inductance on the ground line, supply line, and protected signal lines.

The MAX3202E/MAX3203E/MAX3204E/MAX3206E ESD diodes clamp the voltage on the protected lines during an ESD event and shunt the current to GND or V_{CC}. In an ideal circuit, the clamping voltage, V_C, is defined as the forward voltage drop, V_F, of the protection diode plus any supply voltage present on the cathode.

For positive ESD pulses:

$$V_C = V_{CC} + V_F$$

For negative ESD pulses:

$$V_C = -V_F$$

In reality, the effect of the parasitic series inductance on the lines must also be considered (Figure 1).

For positive ESD pulses:

$$V_C = V_{CC} + V_F(D1) + \left(L1 \times \frac{d(I_{ESD})}{dt} \right) + \left(L2 \times \frac{d(I_{ESD})}{dt} \right)$$

For negative ESD pulses:

$$V_C = - \left(V_F(D2) + \left(L1 \times \frac{d(I_{ESD})}{dt} \right) + \left(L3 \times \frac{d(I_{ESD})}{dt} \right) \right)$$

where I_{ESD} is the ESD current pulse.

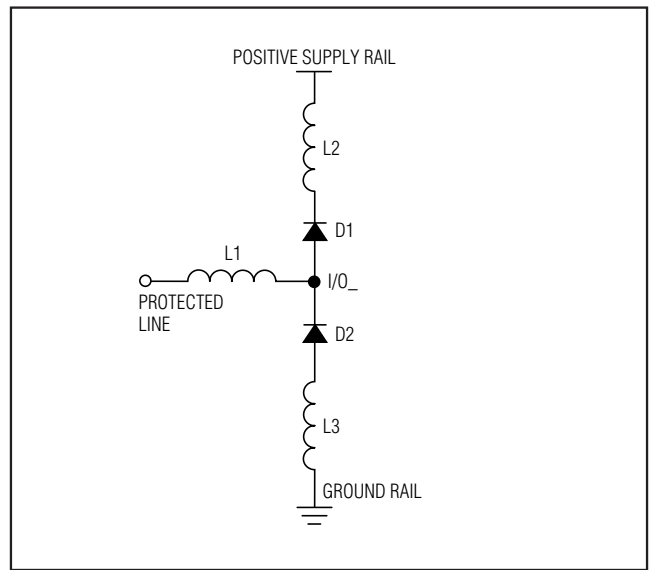

Figure 1. Parasitic Series Inductance

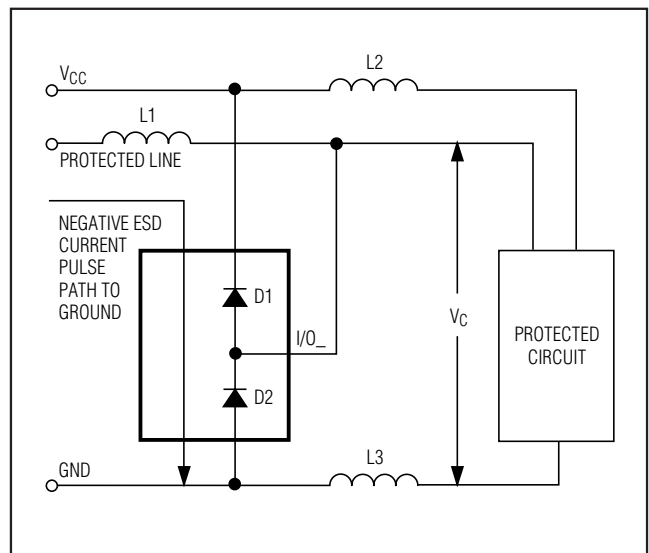

Figure 2. Layout Considerations

Low-Capacitance, 2/3/4/6-Channel, ±15kV ESD Protection Arrays for High-Speed Data Interfaces

During an ESD event, the current pulse rises from zero to peak value in nanoseconds (Figure 3). For example, in a 15kV IEC-61000 Air-Gap Discharge ESD event, the pulse current rises to approximately 45A in 1ns ($di/dt = 45 \times 10^9$). An inductance of only 10nH adds an additional 450V to the clamp voltage. An inductance of 10nH represents approximately 0.5in of board trace. Regardless of the device's specified diode clamp voltage, a poor layout with parasitic inductance significantly increases the effective clamp voltage at the protected signal line.

A low-ESR 0.1µF capacitor must be used between VCC and GND. This bypass capacitor absorbs the charge transferred by an +8kV IEC-61000 Contact Discharge ESD event.

Ideally, the supply rail (VCC) would absorb the charge caused by a positive ESD strike without changing its regulated value. In reality, all power supplies have an effective output impedance on their positive rails. If a power supply's effective output impedance is 1Ω, then by using $V = I \times R$, the clamping voltage of V_C increases by the equation $V_C = I_{ESD} \times R_{OUT}$. An +8kV IEC 61000-4-2 ESD event generates a current spike of 24A, so the clamping voltage increases by $V_C = 24A \times 1\Omega$, or $V_C = 24V$. Again, a poor layout without proper bypassing increases the clamping voltage. A ceramic chip capacitor mounted as close to the MAX3202E/MAX3203E/MAX3204E/MAX3206E VCC pin is the best choice for this application. A bypass capacitor should also be placed as close to the protected device as possible.

±15kV ESD Protection

ESD protection can be tested in various ways; the MAX3202E/MAX3203E/MAX3204E/MAX3206E are characterized for protection to the following limits:

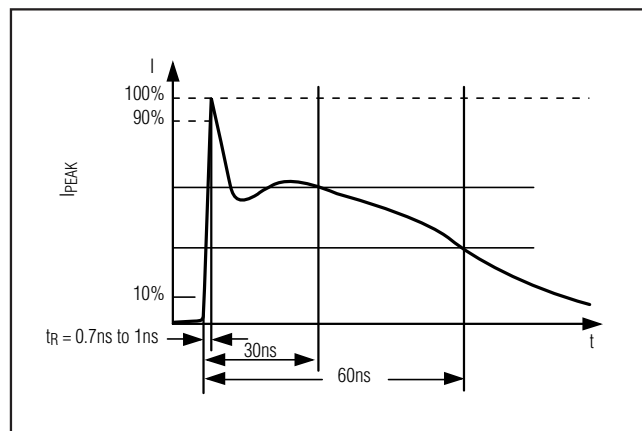

Figure 3. IEC 61000-4-2 ESD Generator Current Waveform

- ±15kV using the Human Body Model
- ±8kV using the Contact Discharge method specified in IEC 61000-4-2
- ±15kV using the IEC 61000-4-2 Air-Gap Discharge method

ESD Test Conditions

ESD performance depends on a number of conditions. Contact Maxim for a reliability report that documents test setup, methodology, and results.

Human Body Model

Figure 4 shows the Human Body Model, and Figure 5 shows the current waveform it generates when discharged into a low impedance. This model consists of a 100pF capacitor charged to the ESD voltage of interest, which is then discharged into the device through a 1.5kΩ resistor.

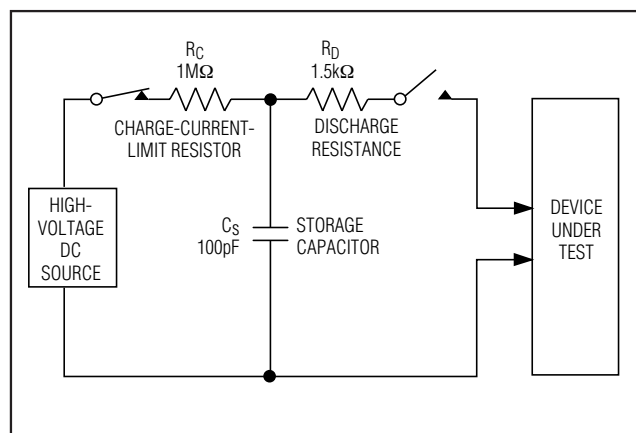

Figure 4. Human Body ESD Test Model

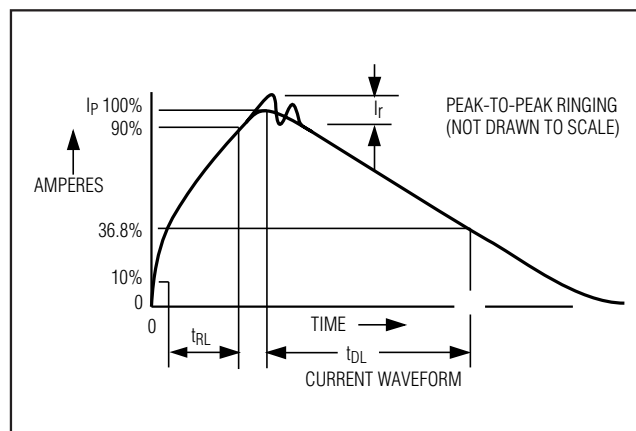

Figure 5. Human Body Model Current Waveform

Low-Capacitance, 2/3/4/6-Channel, ±15kV ESD Protection Arrays for High-Speed Data Interfaces

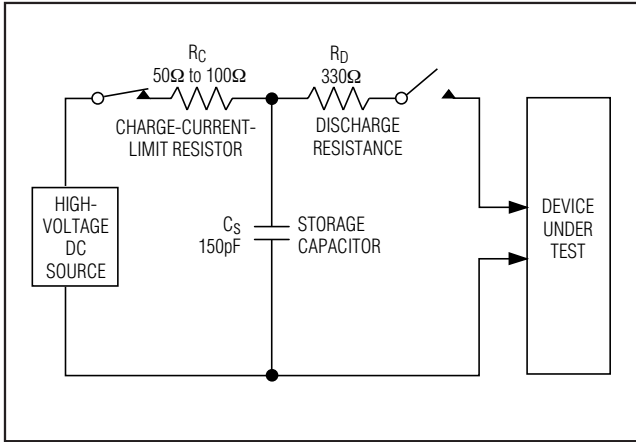

Figure 6. IEC 61000-4-2 ESD Test Model

IEC 61000-4-2

The IEC 61000-4-2 standard covers ESD testing and performance of finished equipment. The MAX3202E/MAX3203E/MAX3204E/MAX3206E help users design equipment that meets Level 4 of IEC 61000-4-2.

The main difference between tests done using the Human Body Model and IEC 61000-4-2 is higher peak current in IEC 61000-4-2. Because series resistance is lower in the IEC 61000-4-2 ESD test model (Figure 6) the ESD-withstand voltage measured to this standard is generally lower than that measured using the Human Body Model. Figure 3 shows the current waveform for the ±8kV IEC 61000-4-2 Level 4 ESD Contact Discharge test.

The Air-Gap Discharge test involves approaching the device with a charged probe. The Contact Discharge method connects the probe to the device before the probe is energized.

Layout Recommendations

Proper circuit-board layout is critical to suppress ESD-induced line transients. The MAX3202E/MAX3203E/MAX3204E/MAX3206E clamp to 100V; however, with improper layout, the voltage spike at the device is much higher. A lead inductance of 10nH with a 45A current spike at a dv/dt of 1ns results in an **ADDITIONAL** 450V spike on the protected line. It is **essential** that the layout of the PC board follows these guidelines:

- 1) Minimize trace length between the connector or input terminal, I/O_, and the protected signal line.
- 2) Use separate planes for power and ground to reduce parasitic inductance and to reduce the impedance to the power rails for shunted ESD current.

- 3) Ensure short ESD transient return paths to GND and VCC.
- 4) Minimize conductive power and ground loops.
- 5) Do not place critical signals near the edge of the PC board.
- 6) Bypass VCC to GND with a low-ESR ceramic capacitor as close to VCC as possible.
- 7) Bypass the supply of the protected device to GND with a low-ESR ceramic capacitor as close to the supply pin as possible.

UCSP Considerations

For general UCSP package information and PC layout considerations, refer to Maxim Application Note 263, *Wafer-Level Chip-Scale Package*.

UCSP Reliability

The UCSP represents a unique packaging form factor that may not perform equally to a packaged product through traditional mechanical reliability tests. UCSP reliability is integrally linked to the user's assembly methods, circuit-board material, and usage environment.

The user should closely review these areas when considering use of a UCSP. Performance through operating life test and moisture resistance remains uncompromised as it is primarily determined by the wafer-fabrication process. Mechanical stress performance is a greater consideration for a UCSP. UCSPs are attached through direct solder contact to the user's PC board, foregoing the inherent stress relief of a packaged product lead frame. Solder-joint contact integrity must be considered. Table 1 shows the testing done to characterize the UCSP reliability performance. In conclusion, the UCSP is capable of performing reliably through environmental stresses as indicated by the results in the table. Additional usage data and recommendations are detailed in the UCSP application note, which can be found on Maxim's website at www.maxim-ic.com.

Chip Information

PROCESS: BiCMOS

Low-Capacitance, 2/3/4/6-Channel, ±15kV ESD Protection Arrays for High-Speed Data Interfaces

Table 1. Reliability Test Data

TEST	CONDITIONS	DURATION	FAILURES PER SAMPLE SIZE
Temperature Cycle	-35°C to +85°C, -40°C to +100°C	150 cycles, 900 cycles	0/10, 0/200
Operating Life	T _A = +70°C	240hr	0/10
Moisture Resistance	-20°C to +60°C, 90% RH	240hr	0/10
Low-Temperature Storage	-20°C	240hr	0/10
Low-Temperature Operational	-10°C	24hr	0/10
Solderability	8hr steam age	—	0/15
ESD	±2000V, Human Body Model	—	0/5
High-Temperature Operating Life	T _J = +150°C	168hr	0/45

Functional Diagrams

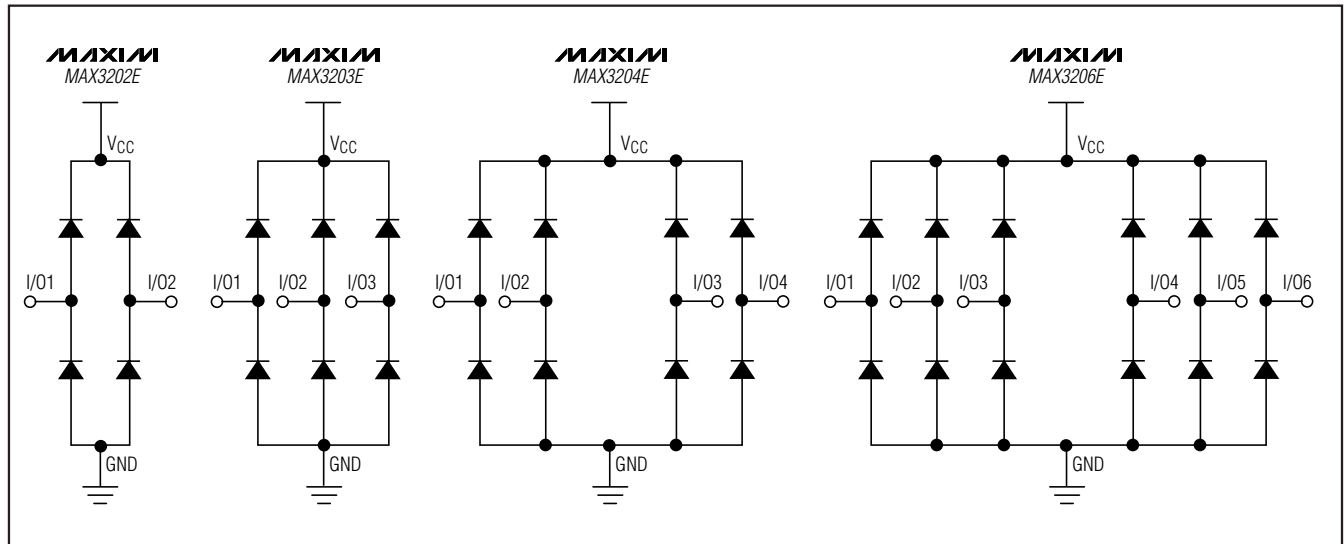

MAX3202E/MAX3203E/MAX3204E/MAX3206E

Low-Capacitance, 2/3/4/6-Channel, ±15kV ESD Protection Arrays for High-Speed Data Interfaces

Pin Configurations

TOP VIEW
(BUMPS ON BOTTOM)

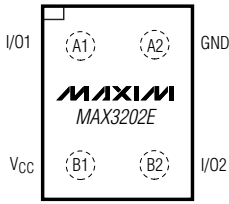

UCSP

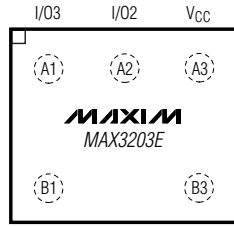

UCSP

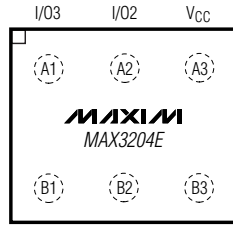

UCSP

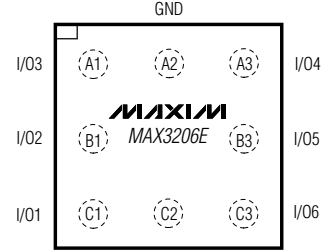

UCSP

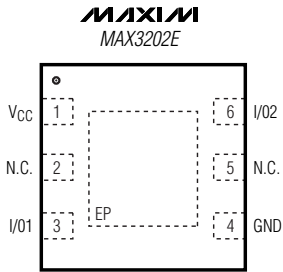

TDFN

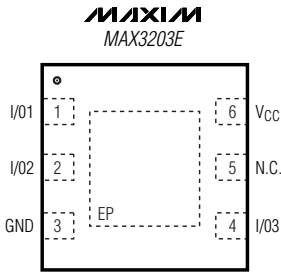

TDFN

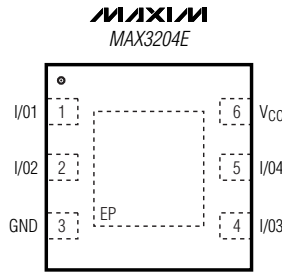

TDFN

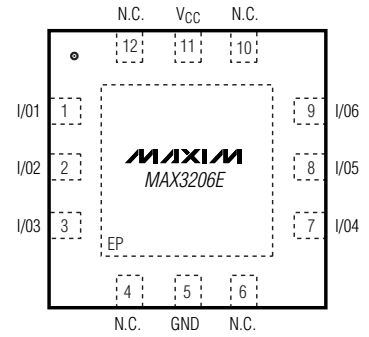

TQFN

EP = EXPOSED PADDLE. CONNECT TO GND.

Low-Capacitance, 2/3/4/6-Channel, ±15kV ESD Protection Arrays for High-Speed Data Interfaces

Package Information

(The package drawing(s) in this data sheet may not reflect the most current specifications. For the latest package outline information go to www.maxim-ic.com/packages.)

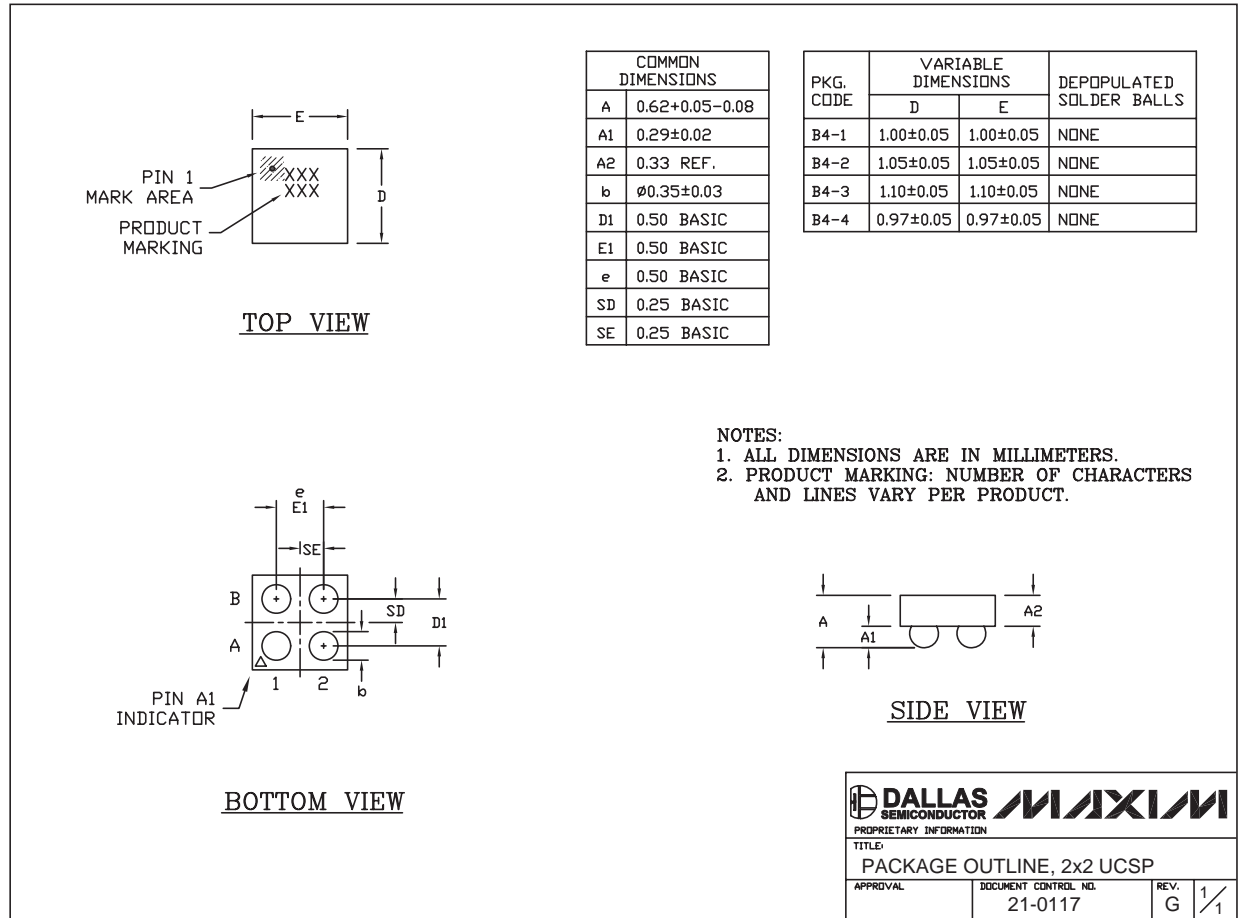

4L UCSP 2x2.EPS

MAX3202E/MAX3203E/MAX3204E/MAX3206E

Low-Capacitance, 2/3/4/6-Channel, ±15kV ESD Protection Arrays for High-Speed Data Interfaces

Package Information (continued)

(The package drawing(s) in this data sheet may not reflect the most current specifications. For the latest package outline information go to www.maxim-ic.com/packages.)

TOP VIEW

COMMON DIMENSIONS	
A	0.62±0.05-0.08
A1	0.29±0.02
A2	0.33 REF.
b	∅0.35±0.03
D1	0.50 BASIC
E1	1.00 BASIC
e	0.50 BASIC
SD	0.25 BASIC
SE	0.00 BASIC

PKG. CODE	VARIABLE DIMENSIONS		DEPOPULATED SOLDER BALLS
	D	E	
B6-1	1.00±0.05	1.52±0.05	NONE
B6-2	1.00±0.05	1.52±0.05	B2
B6-3	1.05±0.05	1.57±0.05	NONE
B6-4	1.05±0.05	1.57±0.05	B2
B6-5	0.97±0.05	1.46±0.05	NONE
B6-6	1.16±0.05	1.57±0.05	NONE

NOTES:

1. ALL DIMENSIONS ARE IN MILLIMETERS.
2. PRODUCT MARKING: NUMBER OF CHARACTERS AND LINES VARY PER PRODUCT.

BOTTOM VIEW

SIDE VIEW

PROPRIETARY INFORMATION

TITLE: PACKAGE OUTLINE, 3x2 UCSP

APPROVAL	DOCUMENT CONTROL NO. 21-0097	REV. G	1/1
----------	---------------------------------	-----------	-----

6L, UCSP:EPS

Low-Capacitance, 2/3/4/6-Channel, ±15kV ESD Protection Arrays for High-Speed Data Interfaces

Package Information (continued)

(The package drawing(s) in this data sheet may not reflect the most current specifications. For the latest package outline information go to www.maxim-ic.com/packages.)

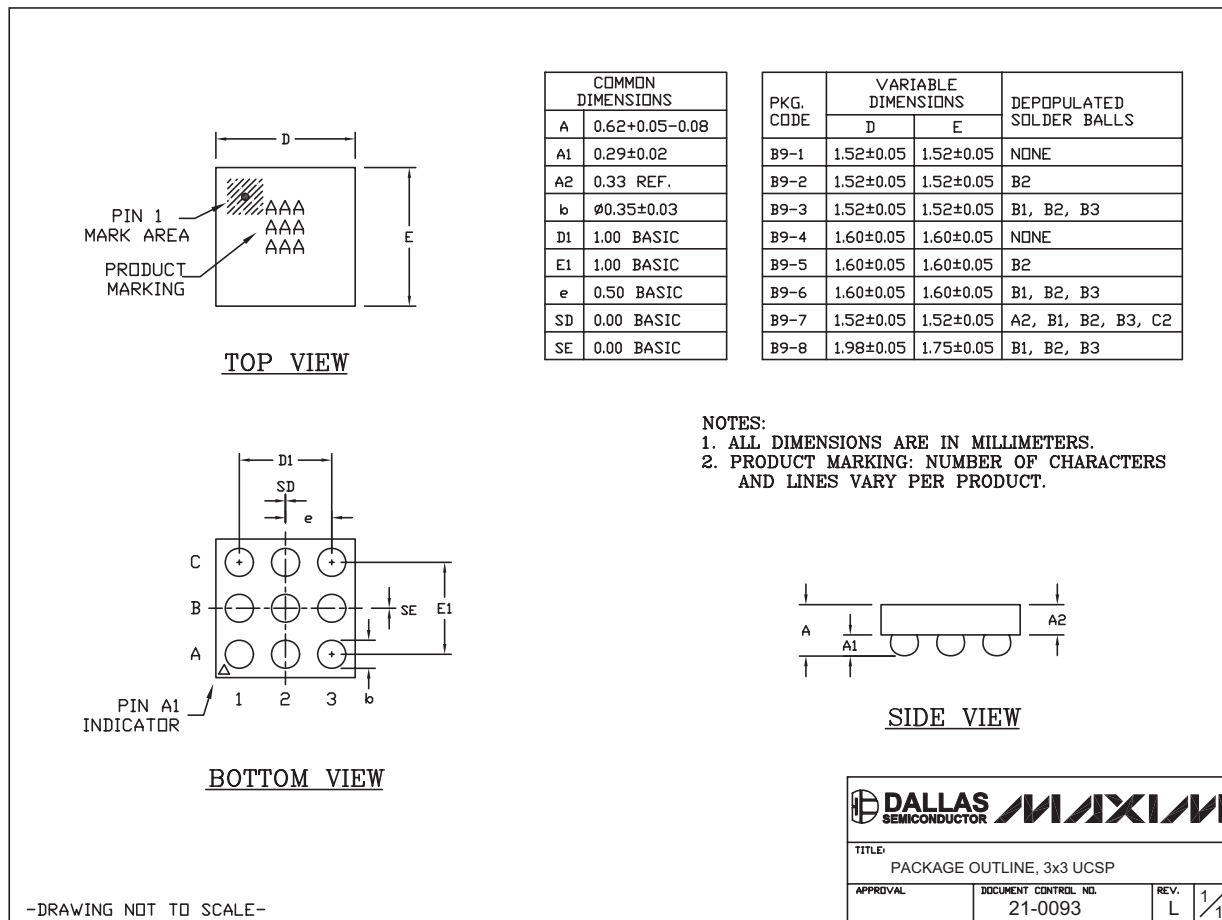

MAX3202E/MAX3203E/MAX3204E/MAX3206E

Low-Capacitance, 2/3/4/6-Channel, ±15kV ESD Protection Arrays for High-Speed Data Interfaces

Package Information (continued)

(The package drawing(s) in this data sheet may not reflect the most current specifications. For the latest package outline information go to www.maxim-ic.com/packages.)

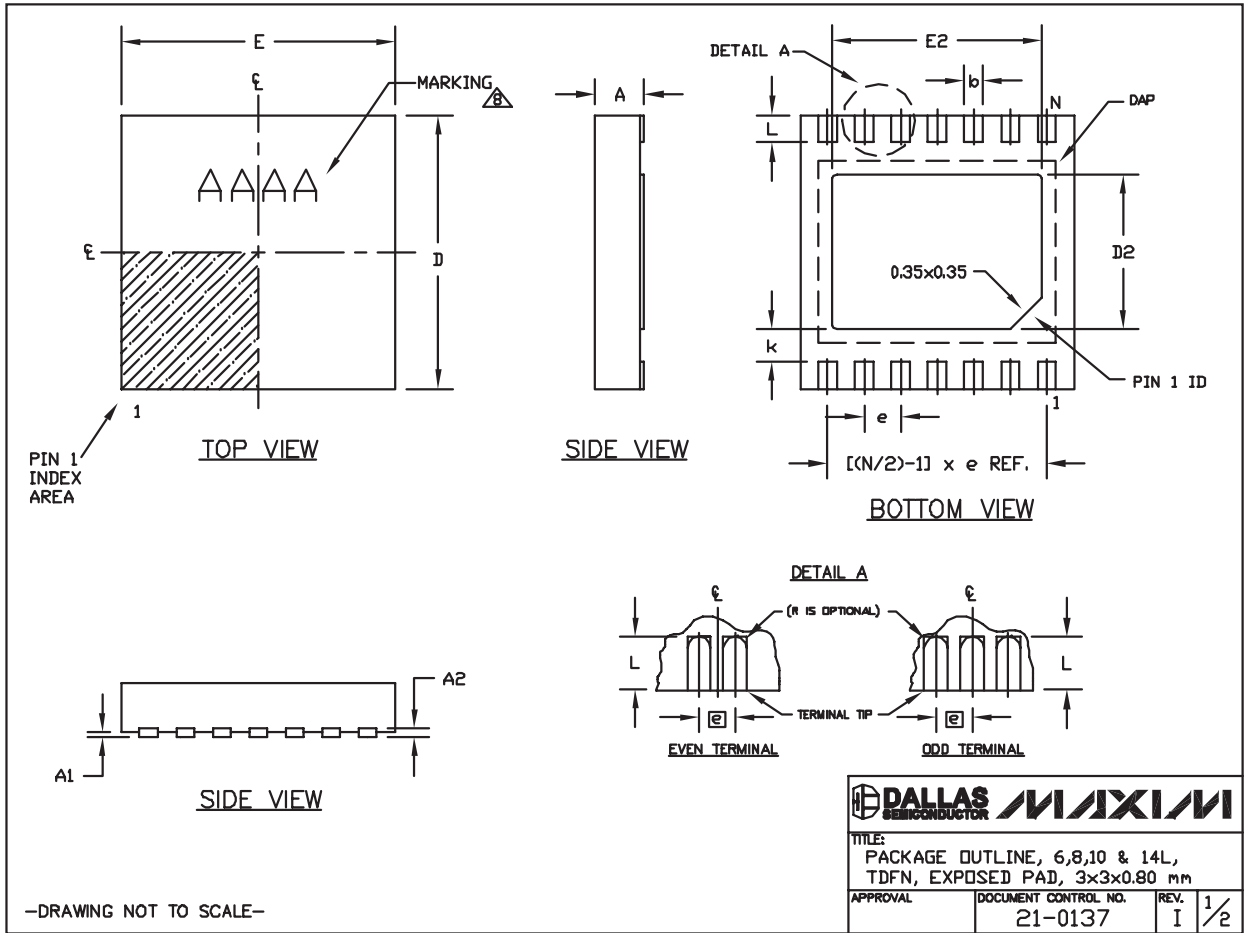

Low-Capacitance, 2/3/4/6-Channel, ±15kV ESD Protection Arrays for High-Speed Data Interfaces

Package Information (continued)

(The package drawing(s) in this data sheet may not reflect the most current specifications. For the latest package outline information go to www.maxim-ic.com/packages.)

COMMON DIMENSIONS		
SYMBOL	MIN.	MAX.
A	0.70	0.80
D	2.90	3.10
E	2.90	3.10
A1	0.00	0.05
L	0.20	0.40
k	0.25 MIN.	
A2	0.20 REF.	

PACKAGE VARIATIONS								
PKG. CODE	N	D2	E2	e	JEDEC SPEC	b	[(N/2)-1] x e	
T633-2	6	1.50±0.10	2.30±0.10	0.95 BSC	MO229 / WEEA	0.40±0.05	1.90 REF	
T833-2	8	1.50±0.10	2.30±0.10	0.65 BSC	MO229 / WEEC	0.30±0.05	1.95 REF	
T833-3	8	1.50±0.10	2.30±0.10	0.65 BSC	MO229 / WEEC	0.30±0.05	1.95 REF	
T1033-1	10	1.50±0.10	2.30±0.10	0.50 BSC	MO229 / WEED-3	0.25±0.05	2.00 REF	
T1033-2	10	1.50±0.10	2.30±0.10	0.50 BSC	MO229 / WEED-3	0.25±0.05	2.00 REF	
T1433-1	14	1.70±0.10	2.30±0.10	0.40 BSC	----	0.20±0.05	2.40 REF	
T1433-2	14	1.70±0.10	2.30±0.10	0.40 BSC	----	0.20±0.05	2.40 REF	

NOTES:

- ALL DIMENSIONS ARE IN mm. ANGLES IN DEGREES.
- COPLANARITY SHALL NOT EXCEED 0.08 mm.
- WARPAGE SHALL NOT EXCEED 0.10 mm.
- PACKAGE LENGTH/PACKAGE WIDTH ARE CONSIDERED AS SPECIAL CHARACTERISTIC(S).
- DRAWING CONFORMS TO JEDEC MO229, EXCEPT DIMENSIONS "D2" AND "E2", AND T1433-1 & T1433-2.
- "N" IS THE TOTAL NUMBER OF LEADS.
- NUMBER OF LEADS SHOWN ARE FOR REFERENCE ONLY.
-  MARKING IS FOR PACKAGE ORIENTATION REFERENCE ONLY.

—DRAWING NOT TO SCALE—

			
TITLE: PACKAGE OUTLINE, 6,8,10 & 14L, TDFN, EXPOSED PAD, 3x3x0.80 mm			
APPROVAL	DOCUMENT CONTROL NO.	REV.	2/2
	21-0137	I	

MAX3202E/MAX3203E/MAX3204E/MAX3206E

