



MAX15038 Evaluation Kit

General Description

The MAX15038 evaluation kit (EV kit) demonstrates the MAX15038 4A, 2MHz step-down regulator with integrated switches for enterprise-server, telecommunication, computing, and networking power-supply applications. The EV kit is preset for a 1.8V output voltage at load currents up to 4A from a 2.9V to 5.5V input-voltage range. A 1MHz switching frequency and up to 95% efficiency (with the supplied components) is achieved by the EV kit.

The MAX15038 EV kit can also be used to evaluate the MAX15039 step-down regulator.

Ordering Information

PART	TYPE
MAX15038EVKIT+	EV Kit

+Denotes lead(Pb)-free and RoHS compliant.

Features

- ◆ Evaluates Internal 31mΩ R_{DS(on)} High-Side and 24mΩ R_{DS(on)} Low-Side MOSFETs
- ◆ 4A Output
- ◆ ±1% Output Accuracy Over Load, Line, and Temperature
- ◆ Operates from 2.9V to 5.5V Input Supply
- ◆ All-Ceramic Capacitor Design
- ◆ 9 Selectable Output Voltages from 0.6V to 2.5V
- ◆ Programmable Output Voltages from 0.6V to (0.9 × V_{IN}) through a Resistor-Divider
- ◆ 500kHz to 2MHz Adjustable Frequency
- ◆ Programmable Soft-Start Time
- ◆ REFIN for DDR Termination and Tracking Applications
- ◆ Proven PCB Layout
- ◆ Lead(Pb)-Free and RoHS Compliant
- ◆ Fully Assembled and Tested

Component List

DESIGNATION	QTY	DESCRIPTION
C1, C2	2	22μF ±10%, 6.3V X5R ceramic capacitors (0805) TDK C2012X5R0J226K
C3, C9	2	0.1μF ±10%, 25V X7R ceramic capacitors (0603) TDK C1608X7R1E104K
C4, C6	2	0.01μF ±10%, 50V X7R ceramic capacitors (0603) TDK C1608X7R1H103K
C5	1	2.2μF ±10%, 16V X5R ceramic capacitor (0603) Murata GRM188R61C225K
C7, C13	0	Not installed, ceramic capacitors (0603)
C8	1	0.022μF ±10%, 50V X7R ceramic capacitor (0603) TDK C1608X7R1H223K
C10	1	560pF ±10%, 50V X7R ceramic capacitor (0603) TDK C1608X7R1H561K
C11	1	1500pF ±10%, 50V X7R ceramic capacitor (0603) TDK C1608X7R1H152K
C12	1	33pF ±5%, 50V C0G ceramic capacitor (0603) TDK C1608C0G1H330CT

DESIGNATION	QTY	DESCRIPTION
C14	0	Not installed, ceramic capacitor (0805)
C15	1	1000pF ±10%, 50V X7R ceramic capacitor (0603) TDK C1608X7R1H102K
IN, OUT, PGND	3	Noninsulated banana jack connectors
JU1, JU2	2	2-pin headers
JU3, JU4, JU5	3	3-pin headers
L1	1	0.47μH, 8.3mΩ, 9.0A inductor (7.7mm x 7mm) TOKO FDV0620-R47
R1	1	2.2Ω ±5% resistor (0603)
R2	1	10kΩ ±5% resistor (0603)
R3	1	1kΩ ±5% resistor (0603)
R4	1	2.67kΩ ±1% resistor (0603)
R5	1	20kΩ ±5% resistor (0603)
R6	1	158Ω ±1% resistor (0603)
R7	1	49.9kΩ ±1% resistor (0603)
R8, R9	0	Not installed, resistors (0603)
U1	1	2MHz buck controller (24 TQFN-EP*) Maxim MAX15038ETG+
—	5	Shunts (JU1–JU5)
—	1	PCB: MAX15038 Evaluation Kit+

*EP = Exposed pad.



MAX15038 Evaluation Kit

Component Suppliers

SUPPLIER	PHONE	WEBSITE
Murata Electronics North America, Inc.	770-436-1300	www.murata-northamerica.com
TDK Corp.	847-803-6100	www.component.tdk.com
TOKO America, Inc.	847-297-0070	www.tokoam.com

Note: Indicate that you are using the MAX15038 or MAX15039 when contacting these component suppliers.

Quick Start

Required Equipment

Before beginning, the following equipment is needed:

- MAX15038 EV kit
- 2.9V to 5.5V, 4A DC power supply
- One digital multimeter (DMM)
- One load up to 4A

Procedure

The MAX15038 EV kit is fully assembled and tested. Follow the steps below to verify board operation.

Caution: Do not turn on the power supply until all connections are completed.

- 1) Preset the DC power supply to 5V and disable the power-supply output.
- 2) Set the load to 4A or less and disable the load.
- 3) Verify that shunts are installed on the EV kit jumpers as follows:
 - JU1: Installed (MAX15038 disabled)
 - JU2: Installed (internal 0.6V reference)
 - $V_{OUT} = 1.8V$:
 - JU3: Not installed
 - JU4: Pins 1-2
 - JU5: Pins 2-3 (forced-PWM mode)
- 4) Connect the power-supply positive terminal to the IN banana jack and the negative terminal to the nearby PGND banana jack.
- 5) Connect the load positive terminal to the OUT banana jack and the negative terminal to the PGND banana jack.
- 6) Set the DMM to measure voltage. Connect the positive terminal to the OUT PCB pad and the negative terminal to the nearby PGND PCB pad.
- 7) Enable the power supply.
- 8) Enable the load.

- 9) Remove the shunt from jumper JU1 (MAX15038 enabled).

- 10) Verify that the DMM measures 1.8V.

Detailed Description of Hardware

The MAX15038 EV kit demonstrates the MAX15038 4A, 2MHz step-down regulator with integrated switches in a 24-pin TQFN surface-mount package with an exposed pad. Applications include enterprise-server, telecommunication, computing, and networking power supplies.

The MAX15038 EV kit generates selectable output voltages from 0.6V to 2.5V at load currents up to 4A. The output voltage should be configured only BEFORE power-up using jumpers JU3 (CTL1) and JU4 (CTL2). Once the IC is enabled using jumper JU1 (EN), jumpers JU3 and JU4 should not be changed until power cycling or disabling the IC. The EV kit can also program the output voltage from 0.6V to $(0.9 \times V_{IN})$ through resistor-dividers R8 and R9. Jumper JU2 (REFIN) configures the EV kit reference voltage as an internal 0.6V reference or a user-supplied 0.6V to $(V_{DD} - 2V)$ voltage reference connected across the REF_IN and GND PCB pads.

The MAX15038 EV kit operates in three different functional modes (forced PWM, monotonic startup, and skip), as configured by jumper JU5 (MODE). The EV kit shows a 1MHz switching frequency and up to 95% efficiency with the supplied components. The EV kit can evaluate other switching frequencies between 500kHz and 2MHz. See the *Evaluating Other Switching Frequencies (FREQ)* section for more information. The EV kit also provides a PWRGD PCB pad to access the IC's power-good logic output. The EV kit operates from a 2.9V to 5.5V input DC power supply connected across the IN and PGND banana jacks.

The MAX15038 EV kit can also be used to evaluate the MAX15039 step-down regulator. See the *Evaluating the MAX15039 IC* section for more information.

Regulator Enable (EN)

The MAX15038 features a shutdown mode to minimize the IC quiescent current. To shut down the IC, install a shunt on jumper JU1. For normal operation, remove the shunt from JU1. See Table 1 to configure jumper JU1.

MAX15038 Evaluation Kit

Table 1. Regulator Enable (JU1)

SHUNT POSITION	EN PIN CONNECTION	MAX15038 FUNCTION
Not installed	Pulled up to IN through resistor R2	Enabled
Installed	GND	Disabled

Table 2. Reference Voltage (JU2)

SHUNT POSITION	REFIN PIN CONNECTION	REFERENCE VOLTAGE
Installed	U1 SS pin	Internal 0.6V reference
Not installed	REF_IN PCB pad through resistor R3	User-supplied reference voltage Range: 0.6V to (VDD - 2V)

Reference Voltage (REFIN)

The MAX15038 uses an internal 0.6V reference or an external reference input. To use the internal 0.6V reference, install a shunt on jumper JU2 shorting U1's REFIN and SS pins.

Alternatively, to use an external reference, perform the following steps:

- 1) Remove the shunt from jumper JU2.
- 2) Install a surface-mount 0603 capacitor at C7 for soft-starting, if needed.
- 3) Connect a 0.6V to (VDD - 2V) reference across the REF_IN and GND PCB pads.

The IC regulates FB to the voltage at U1's REFIN pin. The internal soft-start is not available when using an external reference. Refer to the *Soft-Start and REFIN* section in the MAX15038 IC data sheet for more information on using the REFIN features. See Table 2 to configure jumper JU2.

Evaluating Other Output Voltages

The MAX15038 EV kit comes preset to a 1.8V output voltage. The output voltage is selectable using jumpers JU3 (CTL1) and JU4 (CTL2) to provide three different logic level inputs: VDD, unconnected, and GND. **The logic states of CTL1 and CTL2 should be selected only before power-up.** CTL1 and CTL2 should not be changed once soft-start is complete. If the output voltage needs to be reselected, perform the following steps:

- 1) Disable the regulator using jumper JU1, or remove power.
- 2) Set the CTL1 and CTL2 logic states using jumpers JU3 and JU4.
- 3) Enable the regulator, or apply power.

See Table 3 to configure jumpers JU3 and JU4.

When externally programming the MAX15038, install a 8.06kΩ surface-mount 0603 resistor at R8 and then select a value for a surface-mount 0603 resistor at R9 using the following equation:

$$R9[k\Omega] = \frac{(0.6V \times 8.06k\Omega)}{(V_{OUT} - 0.6V)}$$

where V_{OUT} is the desired output voltage. Refer to the MAX15038 IC data sheet for information on selecting output inductor, capacitor, and compensation components to optimize the circuit for different output voltages.

Table 3. Output-Voltage Selection (JU3, JU4)

SHUNT POSITION (JU3)	CTL1 PIN CONNECTION	SHUNT POSITION (JU4)	CTL2 PIN CONNECTION	V _{out} (V)
2-3	GND	2-3	GND	0.6V* or 0.6V < V _{OUT} ≤ 0.9 × V _{IN} **
1-2	VDD	1-2	VDD	0.7
2-3	GND	Not installed	Unconnected	0.8
2-3	GND	1-2	VDD	1.0
Not installed	Unconnected	2-3	GND	1.2
Not installed	Unconnected	Not installed	Unconnected	1.5
Not installed	Unconnected	1-2	VDD	1.8
1-2	VDD	2-3	GND	2.0
1-2	VDD	Not installed	Unconnected	2.5

*Install a surface-mount 0603 8.06kΩ resistor at R8 and do not install a resistor at R9.

**Install a surface-mount 0603 8.06kΩ resistor at R8 and a resistor at R9 (see the equation in the Evaluating Other Output Voltages section).

MAX15038 Evaluation Kit

Table 4. Mode Selection (JU5)

SHUNT POSITION	MODE PIN CONNECTION	MAX15038 IC FUNCTIONAL MODE
2-3	GND	Forced PWM
Not installed	Unconnected	Forced PWM, monotonic startup into prebiased output
1-2	VDD	Skip, monotonic startup into prebiased output

Mode Selection

The MAX15038 IC's three functional modes (forced PWM, monotonic startup, and skip) are programmable using jumper JU5. Refer to the *Mode Selection* section in the MAX15038 IC data sheet for more information on the IC's three functional modes. See Table 4 to configure jumper JU5.

Evaluating Other Switching Frequencies (FREQ)

The MAX15038 EV kit comes preset at a 1MHz switching frequency. To evaluate other frequencies, select a different value for surface-mount 0603 resistor R7 using the following equation:

$$R7[k\Omega] = \frac{49.9k\Omega}{0.95\mu s} \times \left(\frac{1}{f_s[\text{MHz}]} - 0.05\mu s \right)$$

where f_s is the desired switching frequency in megahertz and must be between 500kHz and 2MHz. Refer to the MAX15038 IC data sheet for information on selecting output inductor, capacitor, and compensation components to optimize the circuit for different switching frequencies.

Power Good (PWRGD)

The MAX15038 PWRGD is an open-drain output that goes to high impedance when V_{FB} is above $0.925 \times V_{REFIN}$ and V_{REFIN} is above 0.54V for at least 48 clock cycles. PWRGD pulls low when V_{FB} is below 90% of V_{REFIN} or V_{REFIN} is below 0.54V for at least 48 clock cycles. PWRGD is also low during shutdown. On the EV kit, the PWRGD PCB pad is pulled up to VDD through resistor R5. Use the GND PCB pad as a ground reference for this signal.

Evaluating the MAX15039 IC

To evaluate the MAX15039ETG+ with the EV kit, replace U1 with a MAX15039. The MAX15039 supports up to 6A loads and comes in a 24-pin TQFN package with an exposed pad. A 6A, 2.9V to 5.5V DC power supply is needed. Refer to the MAX15039 IC data sheet for more information.

MAX15038 Evaluation Kit

Evaluates: MAX15038/MAX15039

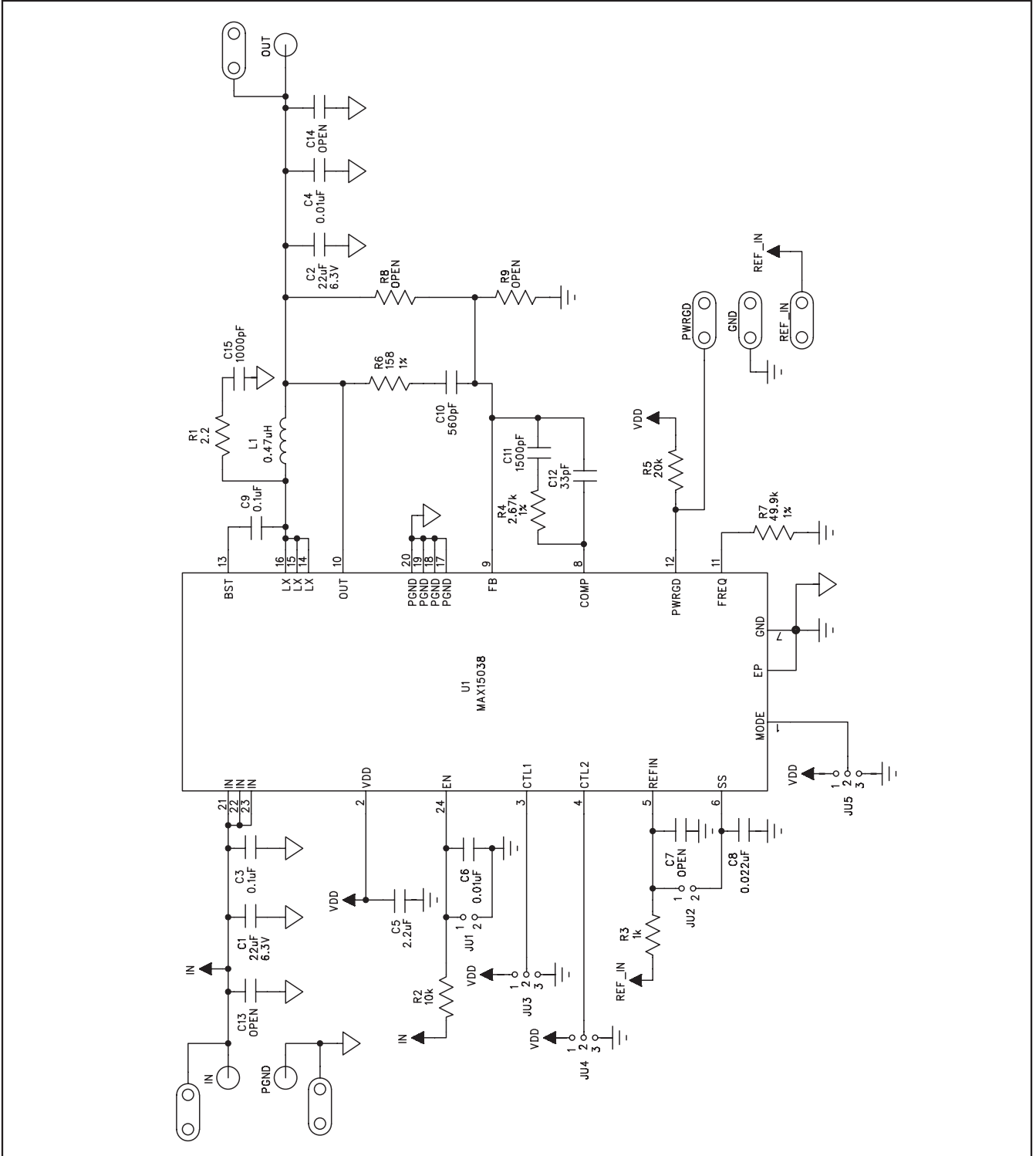

Figure 1. MAX15038 EV Kit Schematic (Application Circuit)

MAX15038 Evaluation Kit

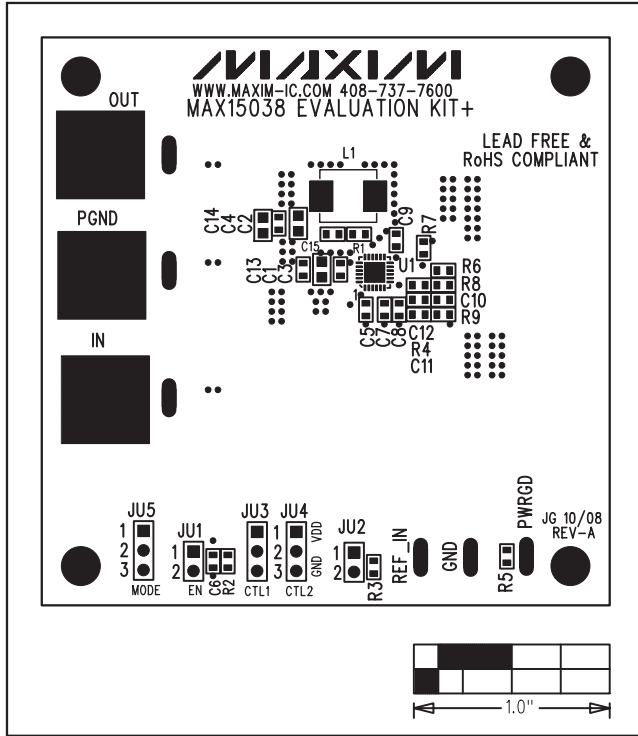

Figure 2. MAX15038 EV Kit Component Placement Guide—Component Side

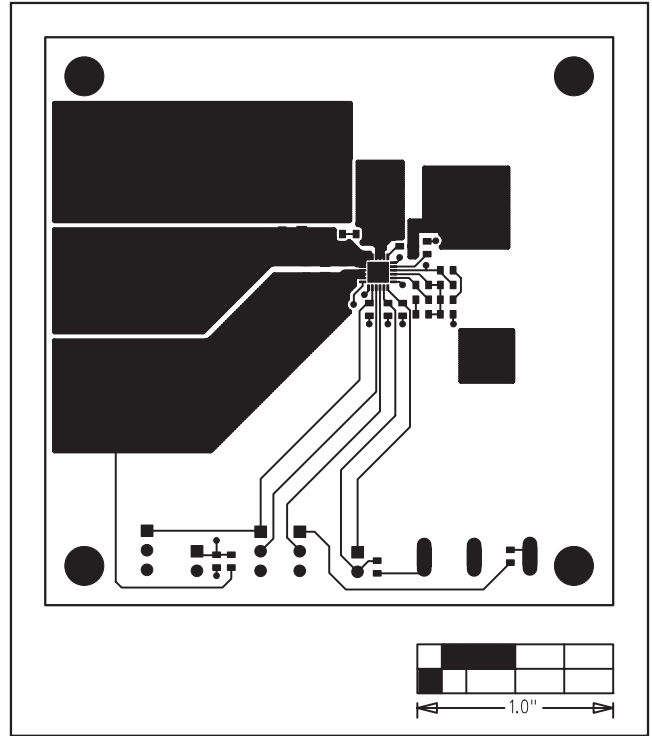

Figure 3. MAX15038 EV Kit PCB Layout—Component Side

MAX15038 Evaluation Kit

Evaluates: MAX15038/MAX15039

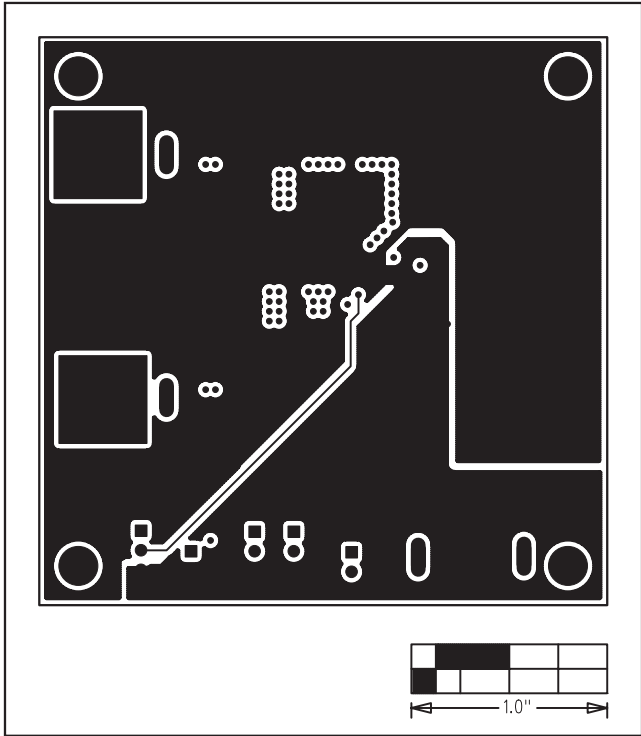

Figure 4. MAX15038 EV Kit PCB Layout—Layer 2

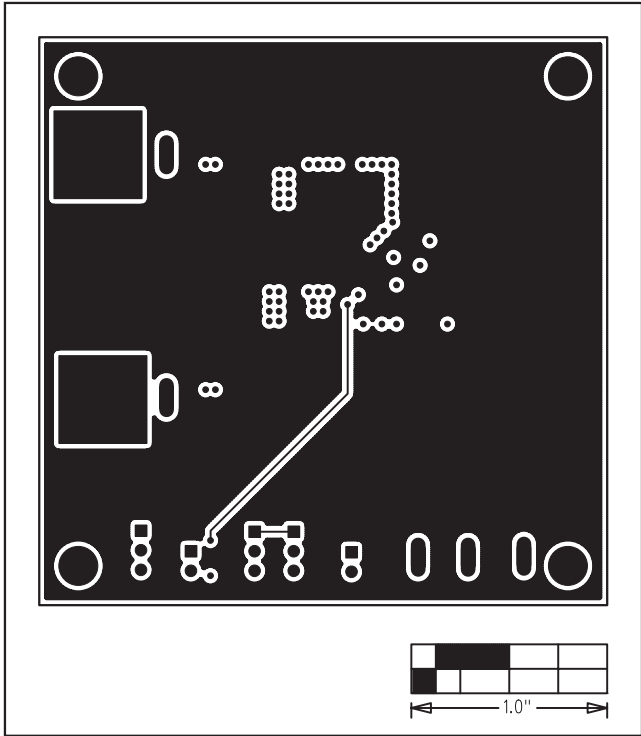

Figure 5. MAX15038 EV Kit PCB Layout—Layer 3

MAX15038 Evaluation Kit

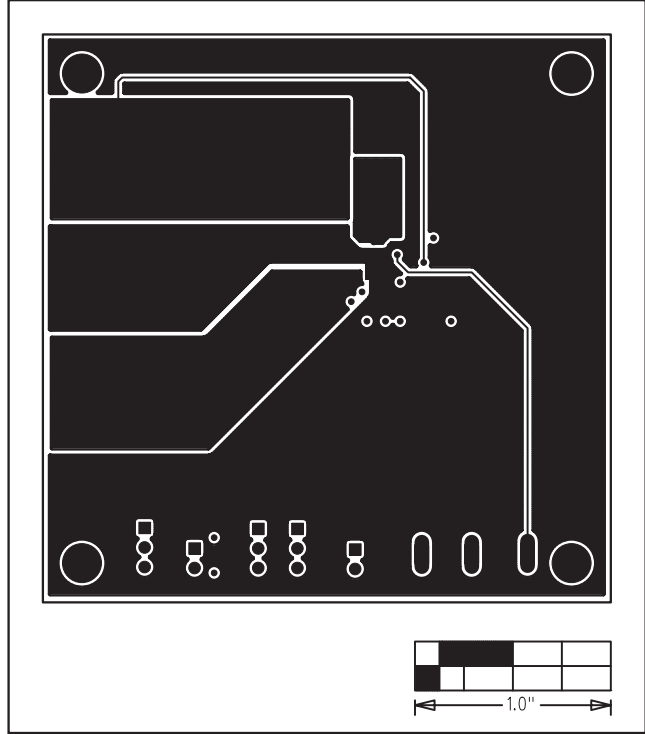

Figure 6. MAX15038 EV Kit PCB Layout—Solder Side

Maxim cannot assume responsibility for use of any circuitry other than circuitry entirely embodied in a Maxim product. No circuit patent licenses are implied. Maxim reserves the right to change the circuitry and specifications without notice at any time.

8 _____ **Maxim Integrated Products, 120 San Gabriel Drive, Sunnyvale, CA 94086 408-737-7600**

© 2008 Maxim Integrated Products

MAXIM is a registered trademark of Maxim Integrated Products, Inc.