

Introduction

The purpose of this application note is to show an example of how a digital potentiometer can be used in the feedback loop of a step-up DC-DC converter to provide calibration and/or adjustment of the output voltage. The example circuit uses a MAX5025 step-up DC-DC converter (capable of generating up to 36V, 120mW max) in conjunction with a DS1845, 256 position, *NV* digital potentiometer. For this example, the desired output voltage is 32V, which is generated from an input supply of 5V. The output voltage can be adjusted in 35mV increments (near 32V) and span a range wide enough to account for resistance, potentiometer and DC-DC converter tolerances (27.6V to 36.7V).

While the intent of this application note is to show an example of a step-up DC-DC converter, the ideas presented here can be applied to generate other combinations of output voltages, step sizes, ranges, and power requirements to meet your particular applications' needs. An additional application note is available (AN225) that shows an example of using a digital potentiometer with a step-down DC-DC converter. A link to AN225 appears at the end of this document.

Fixed Step-up DC-DC Converter

The typical circuit from the MAX5025 data sheet is shown in Figure 1. In this circuit, the output voltage, V_{OUT} , is determined by the ratio of fixed resistors R1 and R2. These two resistors form a voltage divider that feeds a fraction of the output voltage back to the FB pin, creating a closed-loop system. The system is at equilibrium when V_{OUT} is generating the desired output voltage and the R1 and R2 voltage divider feeds back 1.25V to the FB pin. When V_{OUT} is lower than the desired output voltage (and hence the voltage fed back to FB is below 1.25V), the DC-DC converter IC attempts to deliver additional power until FB reaches 1.25V. Equation 1 is directly from the MAX5025 data sheet. Solving Equation 1 for V_{OUT} yields Equation 2 where V_{REF} , the FB Set Point, is 1.25V for the MAX5025.

$$R1 = R2 \left(\frac{V_{OUT}}{V_{REF}} - 1 \right) \tag{Equation 1}$$

$$V_{OUT} = V_{REF} \left(\frac{R1}{R2} + 1 \right) \tag{Equation 2}$$

Figure 1. Fixed Step-Up DC-DC Converter Circuit

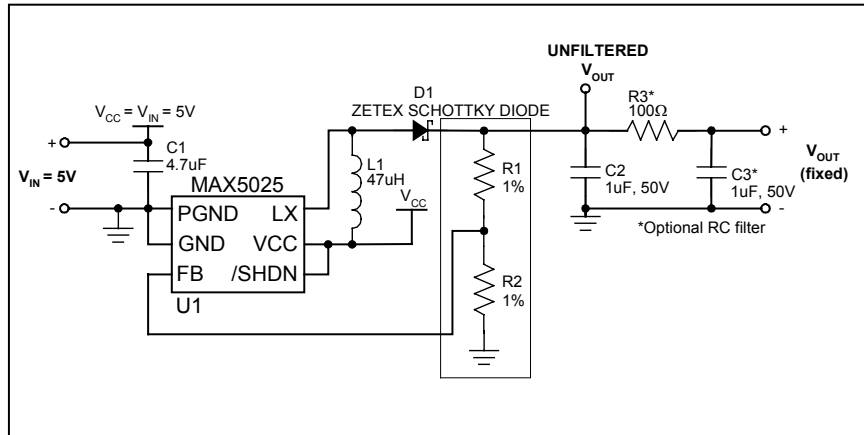

Digital Potentiometer Considerations

One possible way of adding a digital potentiometer into the feedback loop is shown in Figure 2. However, before selecting a digital potentiometer, a number of considerations must be given some thought. The following list of questions address important design considerations and assist in the device selection process.

1. Is a 3V or 5V supply available for the potentiometer?
The majority of digital potentiometers available require 3V or 5V to operate. Likewise, the voltage needs to be available before V_{OUT} can be generated. Since the example circuit has a 5V input supply, this is not a concern here but if V_{IN} were larger, this would be a major concern.
2. Will the system only be calibrated once? Or monitored/controlled closed loop? How will the digital potentiometer be controlled? Using a microcontroller? Push-button?
The answer to these questions will help select a specific digital potentiometer. For example, if the system is going to be calibrated once, say during production testing, then a NV (NV) potentiometer is needed to save the calibrated wiper position. Likewise, it is also important to consider how the potentiometer will be programmed. Will it be programmed with a production tester capable of talking 2-wire or 3-wire, or is a push-button potentiometer needed?
3. How many steps are needed? What resolution is required? What range is needed?
These answers determine the minimum acceptable number of potentiometer positions and serve as a benchmark when experimenting with different resistor values when finding a combination that is acceptable even in worst case conditions due to resistor/component tolerances. Furthermore, be aware that the desired output voltage range will be different than the actual output range so that the desired range can also be obtained even when using worst-case tolerances.
4. What is the max voltage that will ever be applied to the potentiometer terminals? Is V_{REF} (V_{FB}) larger than the maximum allowable voltage on the V_W pin?
Some potentiometers have a specification that states the maximum allowable voltage than can be applied to any of the potentiometer terminals. The second question is intended to be a sanity check. For example, the MAX5027 (not the MAX5025) has a V_{REF} of 30V! This voltage cannot be applied to the wiper terminal. The reason V_{REF} is so high is because it is a non-adjustable DC-DC converter.

5. Is the FB pin bias current large enough to cause a noticeable drop across the wiper resistance, R_W ? Does the FB pin bias current exceed the maximum (or abs max) wiper current specification?
Fortunately, the maximum wiper current specification is usually 1mA or larger, while the bias current is in the magnitude of nA. The second reason why the bias current is important is because if too large, the voltage drop across the wiper resistance becomes noticeable and should be accounted for when calculating the output voltage.
6. Does the minimum and maximum position of the potentiometer connect directly to V_L and V_H ?
For example, the DS1805 is different in that the maximum potentiometer setting (255) does not connect directly to the H terminal. It is actually one resistor (LSB) away from the H terminal. Granted, the difference between 255 and 256 resistors are nil, the same is not the case for potentiometers with fewer positions. The result of this question can be seen later in Equation 4.
7. What is the desired tolerance of V_{OUT} ? 5%? 10%? 3%?
Keep in mind that the DC-DC converter IC itself has a tolerance. The MAX5025 for example has a tolerance of 5%. And this is completely independent from the tolerance of R1 and R2, which may also be 5% or 1%. These tolerances will be discussed in detail later.
8. What is the operating temperature range of the circuit?
Just as important as knowing the effects of the tolerances, it is equally important to know the effects of temperature on the output voltage.

Figure 2. Digital Potentiometer in the Voltage Divider Feedback Path

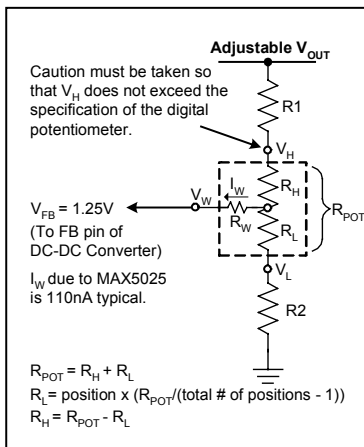

Adding a Digital Potentiometer to the Feedback Path

Although there are several ways that a digital potentiometer could have been added to the circuit in Figure 1, this application note will only discuss the voltage divider configuration as shown in Figure 2. Two configurations that will not be discussed are 1) using the pot as a variable resistor (by connecting the wiper terminal to either the high or low terminal) between R1 and R2, and 2) eliminating R2 and connecting the pot low terminal to ground.

Equations 3, 4, and 5 show the relation of the potentiometers' position to R_L , R_H , and R_{POT} . Once a potentiometer is added into the feedback loop, these equations can be used to modify Equations 1 and 2 to represent the new circuit.

$$R_{POT} = R_H + R_L \quad \text{Equation 3}$$

$$R_L = \text{current potentiometer position} \times \left(\frac{R_{POT}}{(\text{total number of pot positions} - 1)} \right) \quad \text{Equation 4}$$

$$R_H = R_{POT} - R_L \quad \text{Equation 5}$$

R_{POT} is the end-to-end resistance of the potentiometer and R_H and R_L are dependent on the current wiper position setting (see Figure 2). The denominator of Equation 4 is *(total number of pot positions - 1)* if the max and min wiper positions connect directly to the H and L potentiometer terminals, which is true for the DS1845. Some digital potentiometers may have an additional resistor between the max potentiometer setting and the H terminal. The denominator for those potentiometers would not include the -1 and simply be *(total number of pot positions)*.

Equation 2 becomes,

$$V_{OUT} = V_{REF} \left(\frac{R1 + R_H}{R2 + R_L} + 1 \right) \quad \text{Equation 6}$$

Resistor Calculations

Unfortunately, there is no quick, easy way of calculating R1 and R2. V_{OUT} is a function of multiple variables and many solutions exist. Choosing the optimal solution for a particular application involves a decent amount of trial and error. For this reason, a spreadsheet is the single most valuable tool because it allows the designer to make a tweak and instantly see its effects on V_{OUT} for a single potentiometer position as well as a sweep of the entire potentiometer range. The following will describe the process used to calculate the values for the example circuit generating 32V.

Assumptions made up front for this design were, $R_{POT} = 10\text{k}\Omega$, 256 positions, $V_{REF} = V_{FB} = 1.25\text{V}$, and the output voltage will be 32V when the pot is set in the middle position (position 127). The spreadsheet created for this application note can be found on the Dallas Semiconductor ftp site. A link to the spreadsheet can be found at the end of this application note. Plugging the assumptions into Equations 4 and 5, and then into Equation 6 determines the needed ratio between R1 and R2.

$$\frac{V_{OUT}}{V_{REF}} - 1 = \left(\frac{R1 + 5019.6}{R2 + 4980.4} \right) = \frac{32}{1.25} - 1 = 24.6 \quad \text{Equation 7}$$

The MAX5025 data sheet says to choose an R2 in the 5k Ω to 50k Ω range and then calculate R1. However, how can one make an educated R2 selection in such a large range without knowing what else will be effected? The spreadsheet shown in Figure 3 was created specifically for this. Simply type in a value for R2 in the red cell (D7). R1 is then automatically calculated to obtain the ratio in cell Q7 (which was the result of Equation 7). In addition, thousands of other calculations are also performed and then V_{OUT} vs. Pot Position is plotted. The V_{OUT} vs. Pot Position plot shows the expected output voltage for all 256 potentiometer positions. Linearity, range, and slope can all be seen clearly. Look for the trace labeled "Typical". The other traces will be described later. Comparing plots of R2 = 5k Ω and R2 = 50k Ω (Figure 4) it can be seen that smaller values of R2 (Figure 4a) produce a much larger output range, although non-linear and having a steep slope. The steep slope produces larger than desired step sizes (especially at the lower potentiometer positions)

decreasing the resolution of V_{OUT} . Larger values of R2, on the other hand, produce a linear output and much smaller slope (Figure 4b). The smaller the slope, the smaller the step size (and hence resolution). When attempting to “fine-tune” a particular output voltage, it is desirable to have many potentiometer positions at and around the desired output voltage. The drawback, which will be discussed in the following section, is that since R1 and R2 have a tolerance of $\pm 1\%$, there is a possibility that no potentiometer setting will reach 32V. This can be seen looking at the top trace in Figure 4b. When the potentiometer is set to position 0, the output voltage is $\sim 37.5V$ and when the potentiometer is set to position 255, the output only goes down to 32.3V. Therefore, it is important to find a happy medium. For the example circuit, the happy medium (determined by trial and error, entering various values of R2 and looking at the V_{OUT} vs. Pot Position graph ensuring that 32V could be reached in all conditions with an acceptable step size) is 30k Ω . The closest 1% SMT standard value is 30.1k Ω . Plugging this value into the spreadsheet and having it recalculate R1, the closest standard value had to be found for R1 as well. The graph shown in Figure 3 shows that 32V can be obtained even in the worst-case conditions.

Figure 3. Example Resistor and Error Spreadsheet Screenshot

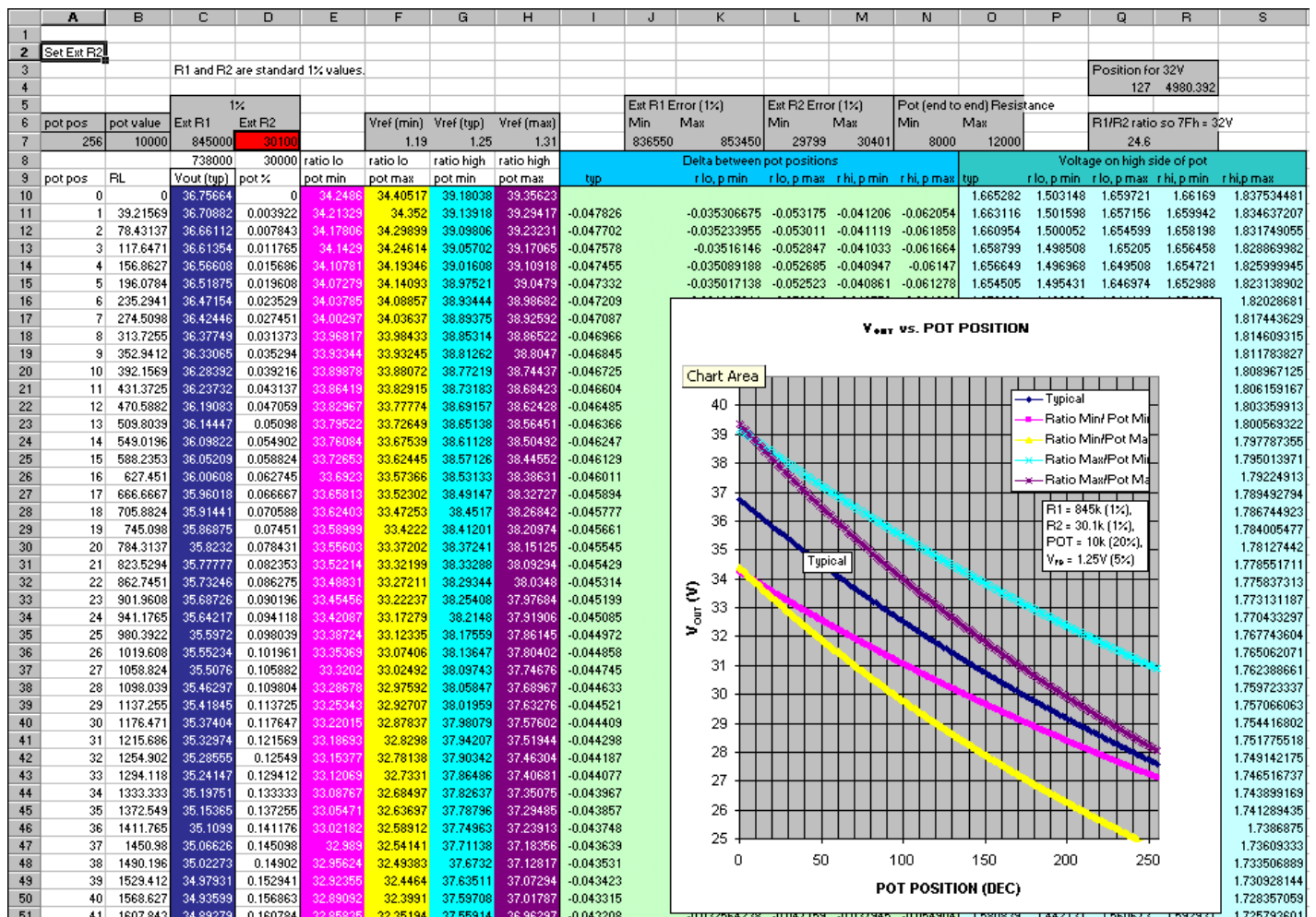

Once values for R1 and R2 are selected, it is important to verify that V_H does not exceed the maximum specification (of V_{CC} + 0.5V for the DS1845). V_H can be calculated using Equation 8.

$$V_H = \frac{V_{OUT}}{(R1 + R2 + R_{POT})} \times (R2 + R_{POT}) \tag{Equation 8}$$

Figure 5 shows a screenshot of the bottom of the example spreadsheet. The calculation of V_H can be seen on the far right along with the max voltage across the potentiometer. We can see that for the resistor values we chose V_H has a worst case potential of 1.84V. This voltage is well within the recommended operating conditions. Other items of interest in Figure 5 are V_{OUT} min/max, min/max deltas between pot positions, and also min/max V_H. While some of the data and calculations shown in the spreadsheet may appear to be of little use, it provides multiple sanity checks to ensure a good design.

Figure 4. R2 Comparison

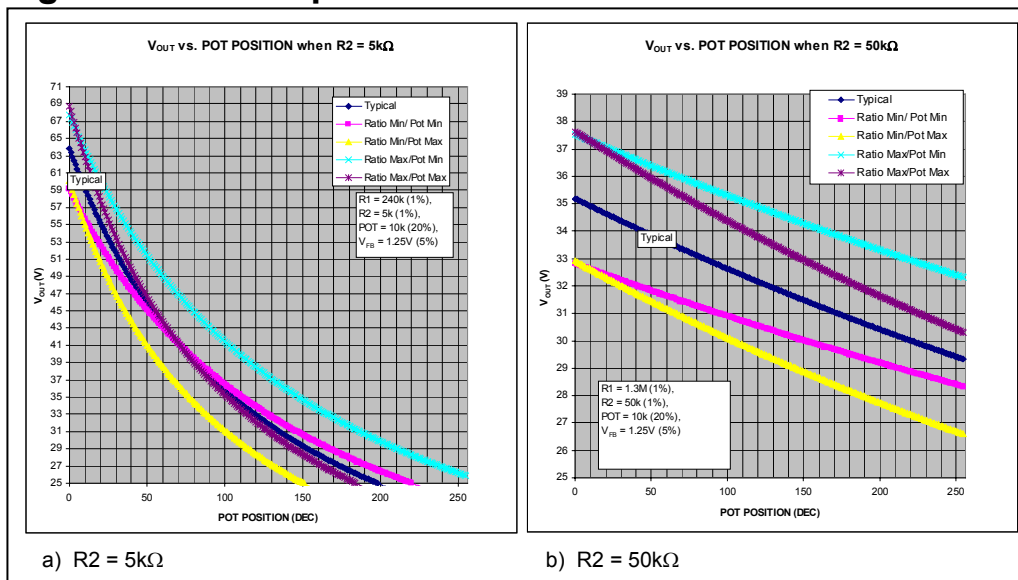

Figure 5. Additional Calculations

262	252	9882.353	27.67158	0.988235	27.18023	24.7505	30.96512	28.1526	-0.027168	-0.022278334	-0.027592	-0.025786	-0.031839	1.253678	1.192924	1.193975	1.31327	1.31443953			
263	253	9921.569	27.64447	0.992157	27.18904	24.72297	30.93938	28.12084	-0.027114	-0.022241873	-0.02753	-0.025743	-0.031767	1.25245	1.191948	1.192647	1.312178	1.312966347			
264	254	9960.784	27.61741	0.996078	27.19583	24.6955	30.91368	28.08914	-0.027061	-0.022205501	-0.027469	-0.025701	-0.031695	1.251224	1.190973	1.191322	1.311088	1.311476508			
265	255	10000	27.5904	1	27.11366	24.66809	30.88802	28.05752	-0.027008	-0.022169218	-0.027408	-0.025658	-0.031624	1.25	1.19	1.19	1.31	1.31			
266																					
267			Vout	min	27.11366	24.66809	30.88802	28.05752	-0.047826	delta bet	-0.02765228	-0.037243	-0.032123	-0.043177	1.665282	1.503148	1.659721	1.66169	1.837534481	<- max Vh	
268				max	34.2486	34.40517	39.18038	39.35623	-0.027008	% (32V)	-0.086413374	-0.1116386	-0.100385	-0.13493	0.415282	0.313148	0.469721	0.35169	0.527534481	<- max voltage across pot	
269																				6.59418E-05	<- max end-to-end current

Conclusion

This application note shows an example of how to use a digital potentiometer in the feedback loop of a step-up DC-DC converter to allow the output voltage to be calibrated. While this application note specifically uses the MAX5025 and the DS1845 to generate 32V, the concepts presented here can be applied towards other potentiometer/converter combinations as well as other output voltages and power ratings.

Questions/comments/suggestions concerning this application note can be sent to:
MixedSignal.Apps@dalsemi.com.

Link to the spreadsheet used in this example:

[ftp.dalsemi.com/pub/system_extension/pots/AN226/AN226.xls](ftp:dalsemi.com/pub/system_extension/pots/AN226/AN226.xls)

Link to Application Note 225 showing a step-down DC-DC converter:

<http://pdfserv.maxim-ic.com/arpdf/AppNotes/app225.pdf>

Maxim Integrated Products / Dallas Semiconductor Contact Information

Dallas Semiconductor

4401 S. Beltwood Parkway
Dallas, TX 75244
Tel: 972-371-4448

World Wide Website:

www.maxim-ic.com

Maxim Integrated Products, Inc

120 San Gabriel Drive
Sunnyvale, CA 94086
Tel: 408-737-7600

Product Information:

<http://www.maxim-ic.com/MaximProducts/products.htm>

Ordering Information:

<http://www.maxim-ic.com/BuyMaxim/Sales.htm>

Product Literature / Samples Requests:
(800) 998-8800

FTP Site:

<ftp://ftp.dalsemi.com>

Sales and Customer Service:
(408) 737-7600

Tech Support:

MixedSignal.Apps@dalsemi.com