

Application Note:

HFAN-4.0.4

Rev.1; 04/08

Jitter in Digital Communication Systems, Part 2



Maxim Integrated Products

Jitter in Digital Communication Systems, Part 2

1 Introduction

A previous application note on jitter, [HFAN-4.0.3 "Jitter in Digital Communication Systems, Part 1,"](#) defined jitter and its various sub-components. The purpose of this application note is to answer the question, "So now that we know what jitter is, why should I care?" To answer this question, we will explore some of the ways that jitter causes bit errors in digital communication systems.

2 Background

A basic characteristic of digital communications systems is the need for synchronization between the binary encoded data (the *bit stream*) and the various circuit elements in the transmitter and receiver. Bit synchronization information is generally conveyed separately in the transmitter and receiver by the *bit clock*, which is a square wave signal that has a frequency (in Hz) equal to the data rate (in bits per second). The relationship between an NRZ encoded bit stream and the bit clock is illustrated in Figure 1.

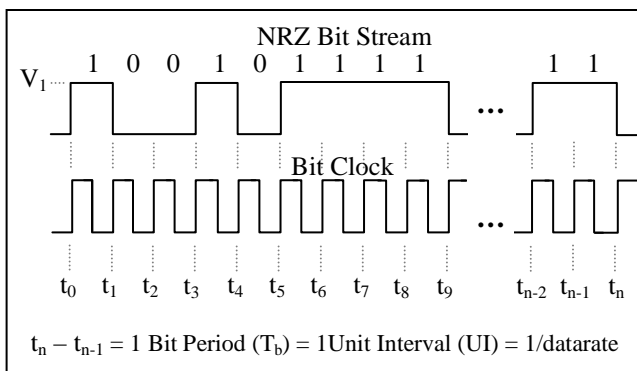

Figure 1. NRZ encoded bit stream

A fundamental problem is how to get the bit synchronization information from the transmitter to the receiver. In general, digital communication systems transmit only the bit stream and then regenerate the bit clock at the receiver through use of a clock and data recovery (CDR) circuit such as Maxim's MAX3873, MAX3875, or MAX3877. Distortions and noise in the received bit stream as well as imperfections in receiver bit clock

regeneration result in mistiming (jitter) between the received bit stream and the regenerated bit clock that can cause bit errors.

3 Receiver Decisions

The receiver in a digital communication system (illustrated in Figure 2) is tasked with accurately making two decisions: (1) when to sample the received bit stream, and (2) whether the sampled value represents a binary one or zero. The bit clock controls the timing of the first decision. Jitter between the bit clock and the bit stream may cause the receiver to sample the bit stream at the wrong time, which can result in bit errors.

To better understand the relationship between jitter and the resulting bit errors, it is necessary to understand the details of the two decisions made by the receiver about each bit. We will first discuss the second decision (one or zero?) and then come back to the first decision (when to sample?).

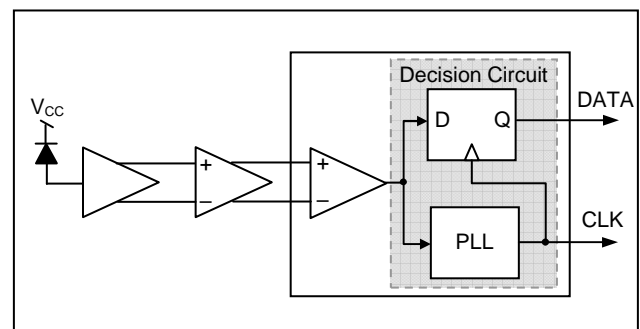

Figure 2. Block-diagram of a fiber-optic receiver

3.1 The One or Zero Decision

The decision circuit in a basic receiver simply compares the sampled voltage, $v(t)$, to a reference value, γ , called the decision threshold. If $v(t)$ is greater than γ , it indicates that a binary one was sent, whereas if $v(t)$ is less than γ , it indicates that a binary zero was sent. Assuming perfect synchronization between the bit stream and the bit clock, the major obstacle to making the correct decision is noise in the received data.

If we assume that additive white Gaussian noise (AWGN) is the dominant cause of erroneous decisions, then we can calculate the statistical probability of making such a decision. The probability density function for $v(t)$ with AWGN can be written mathematically as:

$$PROB[v(t), \sigma_x] = \frac{1}{\sqrt{2\pi\sigma_x^2}} e^{-\frac{1}{2}\left(\frac{v(t)-v_s}{\sigma_x}\right)^2} \quad (1)$$

where v_s is the voltage sent by the transmitter (the mean value of the density function), $v(t)$ is the sampled voltage value in the receiver at time, t , and σ is the standard deviation of the noise. Equation (1) is illustrated in Figure 3.

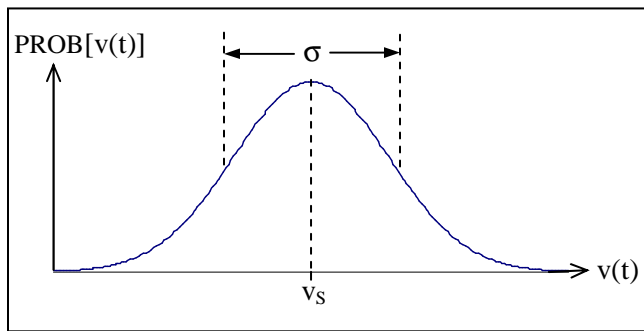

Figure 3. AWGN probability density function

In binary signaling, v_s can take on one of two voltage levels, which we will call v_{s0} and v_{s1} , and the probability of making an erroneous decision in the receiver is:

$$P[\epsilon] = P[v(t) > \gamma | v_s = v_{s0}] P[v_{s0}] + P[v(t) < \gamma | v_s = v_{s1}] P[v_{s1}] \quad (2)$$

where $P[\epsilon]$ is the probability of error and $P[x | y]$ represents the probability of x given y . If we assume an equal probability of sending v_{s0} versus v_{s1} (50% mark density), then $P[v_{s0}] = P[v_{s1}] = 0.5$. Also, in order to simplify the example, we will assume that the same noise effects either voltage level (i.e., $\sigma_0 = \sigma_1$), which means that $P[v(t) > \gamma | v_s = v_{s0}] = P[v(t) < \gamma | v_s = v_{s1}]$. Using these assumptions, equation (2) can be reduced to:

$$P[\epsilon] = P[v(t) > \gamma | v_s = v_{s0}] \times 0.5 + P[v(t) < \gamma | v_s = v_{s1}] \times 0.5 = \frac{1}{2} \int_{-\infty}^{\gamma} PROB[v(t), \sigma_1] dt + \frac{1}{2} \int_{\gamma}^{\infty} PROB[v(t), \sigma_0] dt \quad (3)$$

where $PROB[v(t), \sigma_x]$ is defined in equation (1). This result is illustrated in Figure 4.

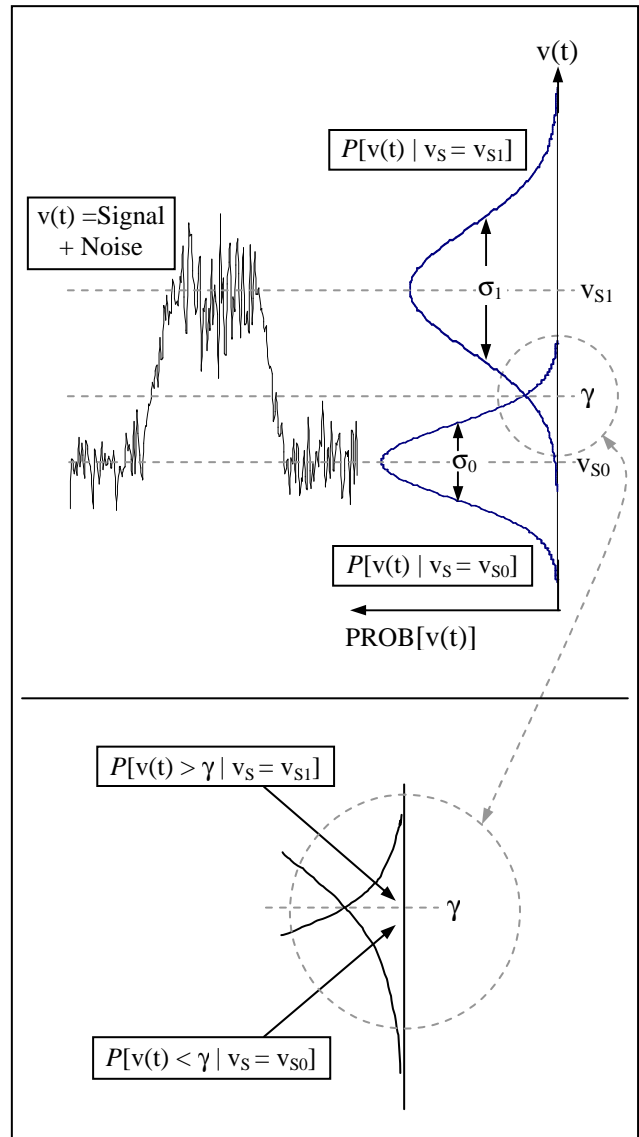

Figure 4. Probability of error for binary signaling

From Figure 4 and equations (2) and (3) we can conclude that the probability of error is equal to the area under the tails of the density functions that extend beyond the threshold, γ . This area, and thus the bit error ratio (BER), is determined by two factors: (1) the standard deviations of the noise (σ_0 and σ_1) and (2) the voltage difference between v_{S0} and v_{S1} (i.e., the signal-to-noise ratio).

It is important to note that for the special case when $\sigma_0 = \sigma_1$, the threshold is halfway between the one and zero levels (i.e., $\gamma = (v_{S1}-v_{S0})/2$). For the more general case when $\sigma_0 \neq \sigma_1$, the optimum threshold for minimum BER will be higher or lower than $(v_{S1}-v_{S0})/2$. For optimum performance, then, the decision circuit include an adjustable threshold level, as in Maxim's MAX3877 and MAX3878.

To simplify computation of the probability of bit error we can rewrite equation (3) in terms of the error function, $Er(x)$, which is defined as¹:

$$Er(x) = \int_x^\infty \frac{1}{\sqrt{2\pi}} e^{\left(\frac{-x^2}{2}\right)} dx \quad (4)$$

for a standard normal distribution (i.e., mean = 0, $\sigma = 1$). [Note that there are a number of variations of this function published in the literature.] This function gives the area under the tail of the Gaussian probability density function (PDF) between x and infinity. This form of the error function is useful because numerical solutions are available in both tabulated form¹ and as built-in functions with many software utilities (e.g., $Er(x) = 1 - \text{NORMSDIST}(x)$ in Microsoft Excel). In terms of $Er(x)$, equation (3) can be rewritten as¹ (see [Maxim application note HFAN-09.0.2](#) for more details on the derivation of this equation):

$$P[\mathcal{E}] = Er\left(\frac{V_1(t) - V_0(t)}{\sigma_0 + \sigma_1}\right) \quad (5)$$

where $[v_1(t) - v_0(t)]/(\sigma_0 + \sigma_1)$ represents the signal-to-noise ratio (sometimes called the "Q-factor")² and $v_1(t)$, $v_0(t)$ are defined in Figure 5.

3.2 Timing of the Sampling Instant

In the receiver, the rising or falling edge of the regenerated bit clock controls the timing of the

sampling circuit. The sampling circuit compares the instantaneous voltage of the input waveform to the decision threshold at an instant in time we will call the *sampling instant* to determine whether the received signal represents a one (received signal $> \gamma$) or a zero (received signal $< \gamma$). Jitter between the bit clock and the bit stream may cause the sampling instant to deviate from the ideal, which can in turn influence the quality of the zero/one decision.

In the previous section it was shown that the probability of making a correct decision is determined by both the noises associated with the input waveform (σ_0 and σ_1) and the difference between the zero and one levels ($v_{S1} - v_{S2}$). The timing location of the sampling instant has no effect on the noise, but it can affect the difference between the zero and one levels and thereby increase the probability of bit errors.

We can represent the timing of the sampling instant by $t_{\text{<subscript>}}$, as shown in Figure 5.

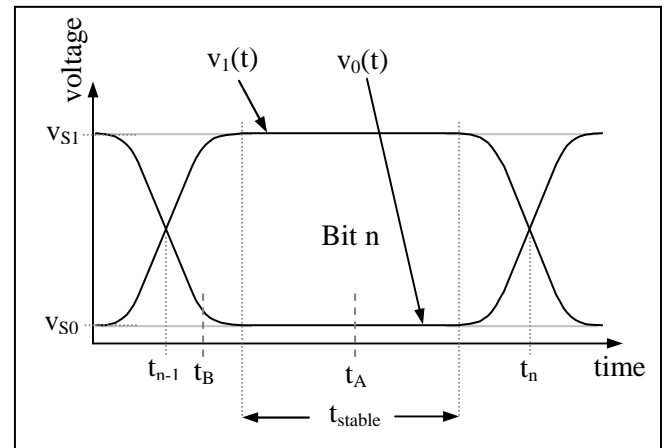

Figure 5. Timing of the sampling instant

From Figure 5 we can see that the difference between v_{S1} and v_{S0} is maximized (and thus the bit error ratio is minimized) when the bit is sampled in the stable region, t_{stable} . If, due to jitter, the bit is sampled between t_{n-1} and t_{stable} or t_{stable} and t_n , then the difference between v_{S1} and v_{S0} will be less than the maximum, resulting in an increased probability of bit error. When the bit is sampled exactly at the transition time or beyond ($t \leq t_{n-1}$ or $t \geq t_n$), the probability of bit error is 50% (assuming 50% mark-density random data).

4 Predicting the BER Caused by Jitter

Some bit errors will occur in the absence of jitter effects (i.e., even with optimum sampling), as a consequence of amplitude noise. (This was discussed in section 3.1). Jitter adds the dimension of time to the problem of predicting the bit error ratio (BER). When jitter is included in the analysis, the calculated probability of bit error, $P[\epsilon]$, must take into account the probability of bit error at each potential sampling instant, $P[\epsilon | t_s]$, as well as the probability that each sampling instance actually occurs, $P[t_s]$.

4.1 Probability of Error at Each Sampling Instant

Equation (5) shows that probability of bit error, $P[\epsilon]$, is determined by the signal amplitude, $v_1(t)-v_0(t)$, and the noise (σ_0 and σ_1). The noise can be directly measured and its magnitude typically stays constant for long periods of time. The sampled signal amplitude, however, may vary depending on the sampling instant. For example, the sampled signal amplitude in Figure 5 will be different when the signal is sampled at t_B than when it is sampled at t_A . This means that $P[\epsilon]$ will be different, depending on the sampling instant.

An example of the relationship between the sampling instant and $P[\epsilon]$ is illustrated in Figures 6, 7, and 8. These figures are discussed in the following paragraphs.

Figure 6(a) represents the eye diagram of the data signal at the input to the sampling circuit in a typical receiver (e.g., the "D" input of Figure 2). We will define the jitter in this eye diagram as the time difference between the data transitions (represented by the zero crossings in the eye diagram) and the corresponding transitions of the bit clock. For such a case, the jitter can be visualized from either of two perspectives: clock-referenced jitter or data-referenced jitter. The clock-referenced perspective involves fixing the horizontal position of the clock and watching the relative horizontal movement of the data eye diagram (this is commonly done in practice by triggering an oscilloscope using the clock signal). The data-referenced perspective can be visualized as fixing the horizontal position of the data eye diagram and watching the relative horizontal movement of the clock signal (data-

referenced jitter). Both of these perspectives are equivalent, but, for purposes of this example, it is more convenient to use the data-referenced perspective.

Using the data referenced perspective, we can neglect jitter in the eye diagram of Figure 6 for now (we will consider all the jitter to be associated with the clock and analyze its effects later). We will, however, assume that the data eye diagram contains amplitude noise (σ_0 and σ_1). We will also assume that we have measured σ_0 and σ_1 (one way to do this is with the vertical histogram mode of the oscilloscope), that they are Gaussian, statistically independent, and that their magnitudes are constant. We also note that the time between the zero crossings represents one unit interval (UI), that the rise and fall times are different, and that, in the general case, there may be other distortions.

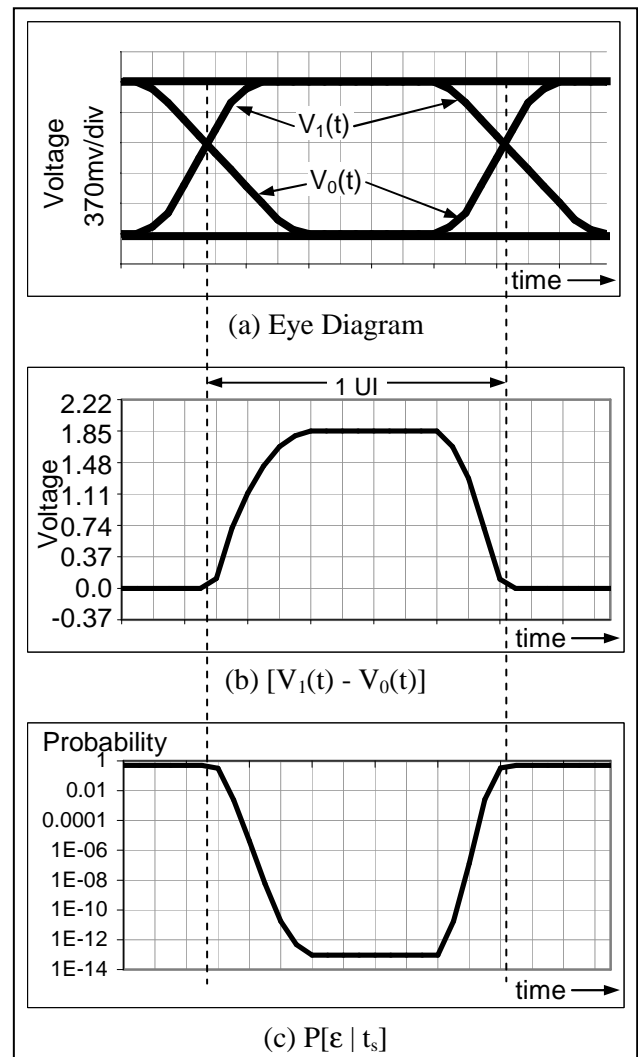

Figure 6. Computing $P[\epsilon]$ at each sampling instant

Figure 6(b) is a plot of the eye diagram amplitude difference, $v_1(t)-v_0(t)$, versus time. This was generated by subtracting the average value of $v_0(t)$ from the average value of $v_1(t)$ at each point in time within the UI. Outside of the UI, we will set the amplitude difference to zero.

Figure 6(c) is a plot of the probability of bit error at each sampling instant, $P[\epsilon | t_s]$. This plot shows the probability that the bit will be erroneously detected as a function of the sampling instant. Figure 6(c) was generated by applying equation (5), using each time instant in Figure 6(b) for the numerator of the argument and, for purposes of this example, setting $\sigma_0 + \sigma_1 = 0.25$.

The plot in Figure 6(c) is commonly called a "jitter bathtub plot", and can be generated using the "BERT Scan Technique³." It is important to note, however, that there are some key differences between the plot of Figure 6(c) and the conventional jitter bathtub plot. For example, Figure 6(c) was generated from a jitter-free eye diagram and thus does not include any jitter. The roll-off on the sides of the plot is due to the non-zero rise and fall times and the asymmetry between the two sides is due to the difference between the rise and fall times. Much of the jitter bathtub plot analysis contained in the literature relies on the assumption that the probability of bit error is zero for all sampling instants within the UI and 50% outside of the UI (i.e., infinitely short rise/fall times and/or negligible amplitude noise). If this assumption were true (i.e., $P[\epsilon] = 0$ for all sampling instants within the UI), then the sides of the jitter-free bathtub plot would be vertical and the bottom of the bathtub plot would be a horizontal line at a probability of zero.

As an important side note, we notice that, as a general rule, the left and right sides of any given data eye diagram are not symmetrical. Because of this asymmetry, as well as other factors such as the setup and hold times of the receiver decision circuit, it may be advantageous (i.e., improve the BER) to shift the sampling time to a position other than the center of the eye diagram. This can be done using the phase-adjust feature of Maxim's MAX3877 and MAX3878.

4.2 Sampling Time Probability

The sampling instant for each bit in any bit pattern is determined by the timing relationship between the

data and the clock. This relationship will vary from one bit to the next, due to jitter. Using the data referenced jitter perspective (described in the previous section) the probability that the sampling instant (i.e., clock transition) occurs at any given time in the UI can be represented by a probability density function (PDF)⁴ of the jitter. This PDF can then be used in conjunction with the probability of bit error at each sampling instant (Figure 6(c)) to compute the overall probability of bit error.

Figure 7 is a modeled example of a sampling instant PDF (i.e., jitter histogram) plotted on both linear and logarithmic vertical scales. This PDF represents the timing probability of the recovered bit clock relative to the data at the input to the receiver sampling circuit.

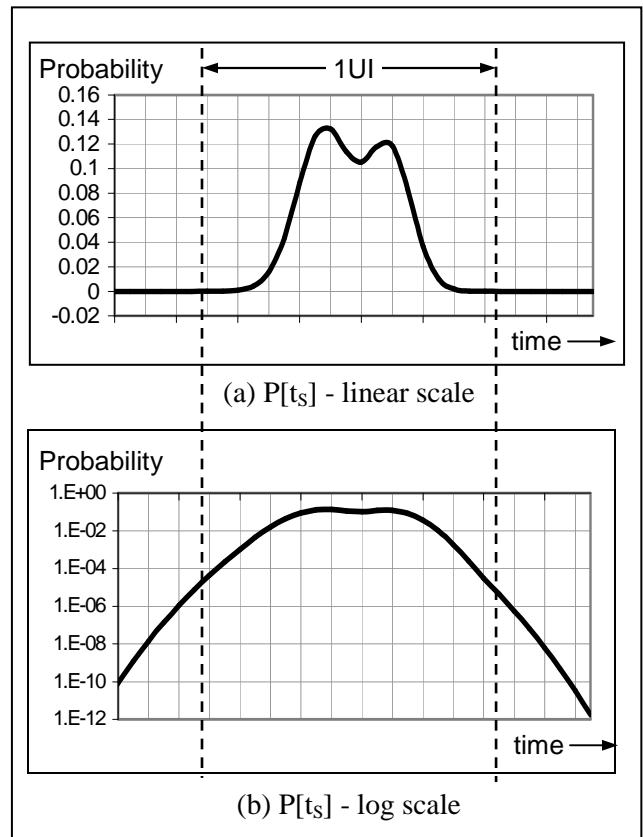

Figure 7. Sampling instant probability density function (PDF)

The key point to notice in Figure 7 is that, even though it is highly probable that the bit will be sampled in the vicinity of the center of the UI, there is still a finite probability, due to jitter, that the bit will be sampled in the vicinity of the bit transition or beyond.

4.3 BER due to Jitter

At this point we finally have all of the information necessary to compute the bit error ratio (BER) due to jitter. In order to do this, we can apply the statistical definition of conditional probability⁵ to compute the probability of bit error over the full range of sampling times, as shown in the following equation:

$$P[\epsilon, t_s] = P[\epsilon | t_s] \times P[t_s] \quad (6)$$

In accordance with equation (6), we can do a point-by-point multiplication of the jitter-free bathtub plot of Figure 6(c) (i.e., $P[\epsilon | t_s]$) and sampling instant PDF of Figure 7 (i.e., $P[t_s]$). The result is the total probability of bit error distributed over the full range of possible sampling time instants. This result is plotted in Figure 8. It is interesting to note from Figure 8 that most of the bit errors in this example occur near the bit transition times, and that these errors are caused by the relatively improbable extremes in sampling instant deviation (i.e., jitter).

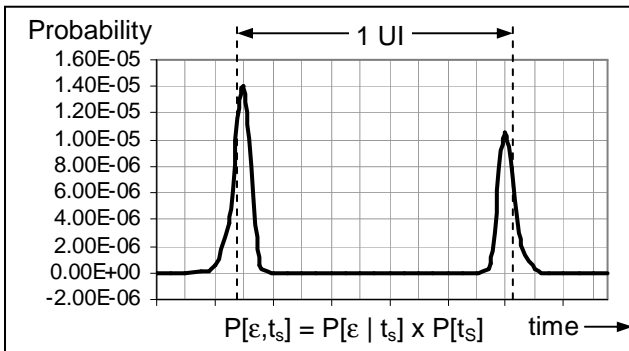

Figure 8. Probability of bit error over the range of possible sampling instants

The cumulative $P[\epsilon]$ (i.e., BER) can be computed by integrating the result of equation (6) with respect to time:

$$BER = \int_{-\infty}^{\infty} P[\epsilon, t_s] dt \quad (7)$$

Numerical integration of the example plot of Figure 8 (i.e., the cumulative area under the curve) yields a BER due to jitter of 3.27×10^{-5} . This result is in contrast to the jitter-free BER at the center of the bathtub plot of Figure 6(c) of 9.27×10^{-14} . (Jitter-free BER assumes optimum sampling near the center of the UI.)

5 Conclusions

Jitter can cause bit errors by shifting the bit sampling instant away from the optimum position and into regions of the bit time that are close to (or beyond) the bit transition points (at the rising and falling edges). It is possible to predict the effect of jitter on the system BER using measurements of the eye diagram, noise, and jitter PDF.

The example jitter BER calculations outlined in this application note show that there may be a significant difference in results depending on whether jitter is considered. (*Note: The examples herein include intentionally exaggerated noise and jitter amplitudes in order to more effectively illustrate the manner in which jitter affects BER.*) Some important observations are as follows:

1. If the jitter is small enough, the resulting timing deviations of the sample clock will be confined to the "stable region" of the bit period (defined in Figure 5), in which case the jitter will have no effect on the BER.
2. The stable region of the bit period can be increased (and thus susceptibility to jitter decreased) by decreasing the rise and fall times and/or decreasing the noise.
3. Some of the existing literature on jitter utilizes unwritten assumptions that rise/fall times are infinitely short, that there is no amplitude noise, and/or that there is no distortion inherent in the eye diagram. In order to make accurate predictions of jitter BER, it is important to consider these effects.

¹ B. Sklar, *Digital Communications: Fundamentals and Applications*, Englewood Cliffs, New Jersey: Prentice Hall, pp. 741-743

² N.S. Bergano, F.W. Kerfoot, and C.R. Davidson, "Margin Measurements in Optical Amplifier Systems," in *IEEE Photonics Technology Letters*, vol.5, no. 3, pp. 304-306, Mar. 1993.

³ National Committee for Information Technology Standardization (NCITS), *T11.2/Project 1230, Rev8 (working draft)*, <http://www.t11.org>, 15 march 1999.

⁴ K.S. Shanmugan and A.M. Breipohl, *Random Signals: Detection, Estimation, and Data Analysis*, New York: John Wiley and Sons, pp. 33-34.

⁵ A. Papoulis, *Probability, Random Variables, and Stochastic Processes*, New York, New York: McGraw-Hill, pp. 27.