



APPLICATION NOTE 982

## Low-Power, 32kHz Oscillator Operates Over Wide Supply Range

*Abstract: Simple oscillator circuit handling a wide supply range using a crystal oscillator and the MAX931, a comparator plus reference chip.*

A 32kHz oscillator is often used to generate a system clock or auxiliary sleep clock in low-power instruments and microcontrollers ( $\mu$ Cs). The usual implementation is a CMOS inverter (74HC04 or CD4049UB type) biased as a linear amplifier by connecting a large-valued resistor from the input to the output.

Inverter circuits present problems, however. Supply currents fluctuate widely over a 3V to 6V supply range, and currents below 250 $\mu$ A are difficult to attain. Operation can be unreliable for wide variations in supply voltage. Further, the inverter's input characteristics can vary widely (especially among different manufacturers), and they are not guaranteed.

A very low-power crystal oscillator solves these problems (**Figure 1**). Drawing only 13 $\mu$ A from a 3V supply, it consists of a single-transistor amplifier/oscillator (Q1) and a low-power comparator/reference device (IC1). Q1's base is biased at 1.25V via R5, R4, and the reference in IC1.  $V_{BE}$  is about 0.7V, placing the emitter at approximately 0.5V.

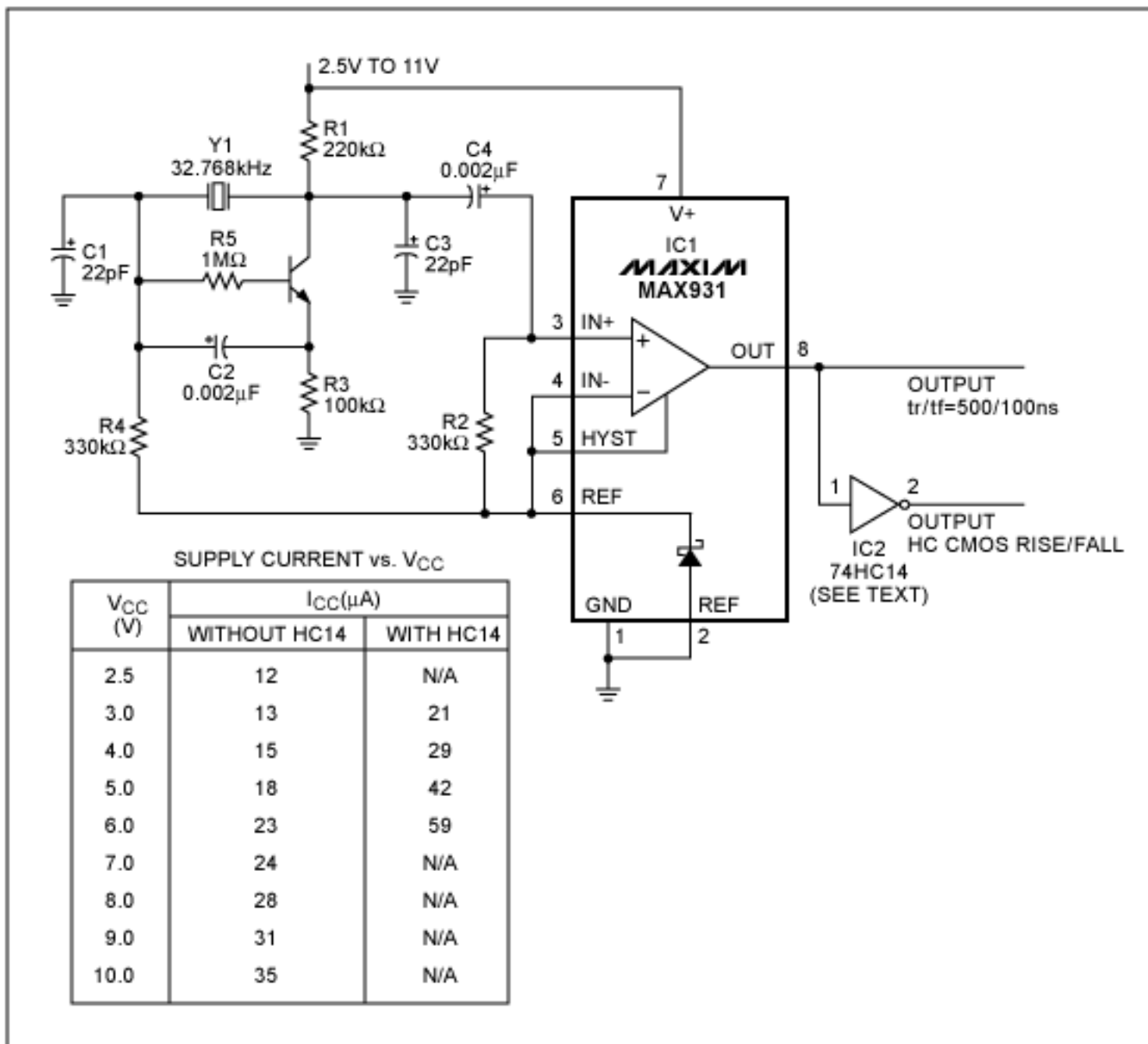

Figure 1. This 32kHz, low-power clock oscillator offers numerous advantages over conventional oscillator circuits based on a CMOS inverter (see text).

This constant voltage across R3 sets the transistor's quiescent current at  $5\mu\text{A}$ , which fixes the collector voltage at about 1V below  $V_{CC}$ . The amplifier's nominal gain ( $R1/R2$ ) is approximately 2V/V.

The crystal combined with the load capacitors C1 and C3 forms a feedback path around Q1, whose  $180^\circ$  of phase shift causes the oscillation. C4 couples this signal to the comparator input, whose quiescent voltage (1.25V) is set by the reference via R2. The comparator's input swing is thus centered around the reference voltage. Operating at 3V and 32kHz, IC1 draws about  $7\mu\text{A}$ .

The comparator output can source 40mA and sink 5mA—more than enough for most low-power loads. The moderate-speed rise/fall times, however (500ns and 100ns, respectively), can cause standard, high-speed CMOS logic to draw higher-than-normal switching currents. In that case, the optional Schmitt trigger shown (IC2) can handle the comparator's rise/fall times with only a small penalty in supply current (see table in Figure 1). You can omit the Schmitt trigger if the oscillator drives a  $\mu\text{C}$ 's crystal-input terminal.

Unlike inverter-based oscillators (which exhibit start-up difficulties, finicky operation, and a decade of change in supply current over the 3V to 6V range), this circuit starts quickly and reliably at any supply voltage. Component

values are generally not critical, and for Q1, you can substitute any small-signal transistor with a decent beta of 100 or so at 5 $\mu$ A. Supply currents are nearly flat over the 2.5V to 11V supply range (the maximum allowed for IC1).

---

Application Note 982: <http://www.maxim-ic.com/an982>

### **More Information**

For technical questions and support: <http://www.maxim-ic.com/support>

For samples: <http://www.maxim-ic.com/samples>

Other questions and comments: <http://www.maxim-ic.com/contact>

### **Related Parts**

MAX931: [QuickView](#) -- [Full \(PDF\) Data Sheet](#) -- [Free Samples](#)

AN982, AN 982, APP982, Appnote982, Appnote 982

Copyright © by Maxim Integrated Products

Additional legal notices: <http://www.maxim-ic.com/legal>