

APPLICATION NOTE 955

# Analog Switch Expands I<sup>2</sup>C Interface

*Abstract: Design idea outlining how to use an I<sup>2</sup>C-controlled analog switch to triple the number of devices connected to an I<sup>2</sup>C bus.*

Perhaps the most effective way to gain board space and increase component density is to minimize wiring on the board. A widely used architecture that allows such miniaturization is the I<sup>2</sup>C bus. Comprising only a bidirectional data line, SDA, and a clock line, SCL, this bus requires no chip selects or other additional connections.

Microcontrollers from Philips, Microchip, and other manufacturers include dedicated I<sup>2</sup>C interfaces, but you can also implement the interface in software. To complete this task, you associate a 7-bit address with each master or slave transceiver and factory- or pin-program the device with two to four address options.

An increasing number of slaves now include the I<sup>2</sup>C interface, but some of their 128 address locations are reserved for special functions, so not all locations are available to a designer. Yet, two or more devices could have the same address in some applications.

In **Figure 1**, analog switch IC<sub>1</sub>, which is I<sup>2</sup>C-controlled, connects auxiliary branches that contain devices with the same address to the main I<sup>2</sup>C bus. IC<sub>2</sub> and IC<sub>3</sub>, for example, have the same address address but are located on different auxiliary buses.

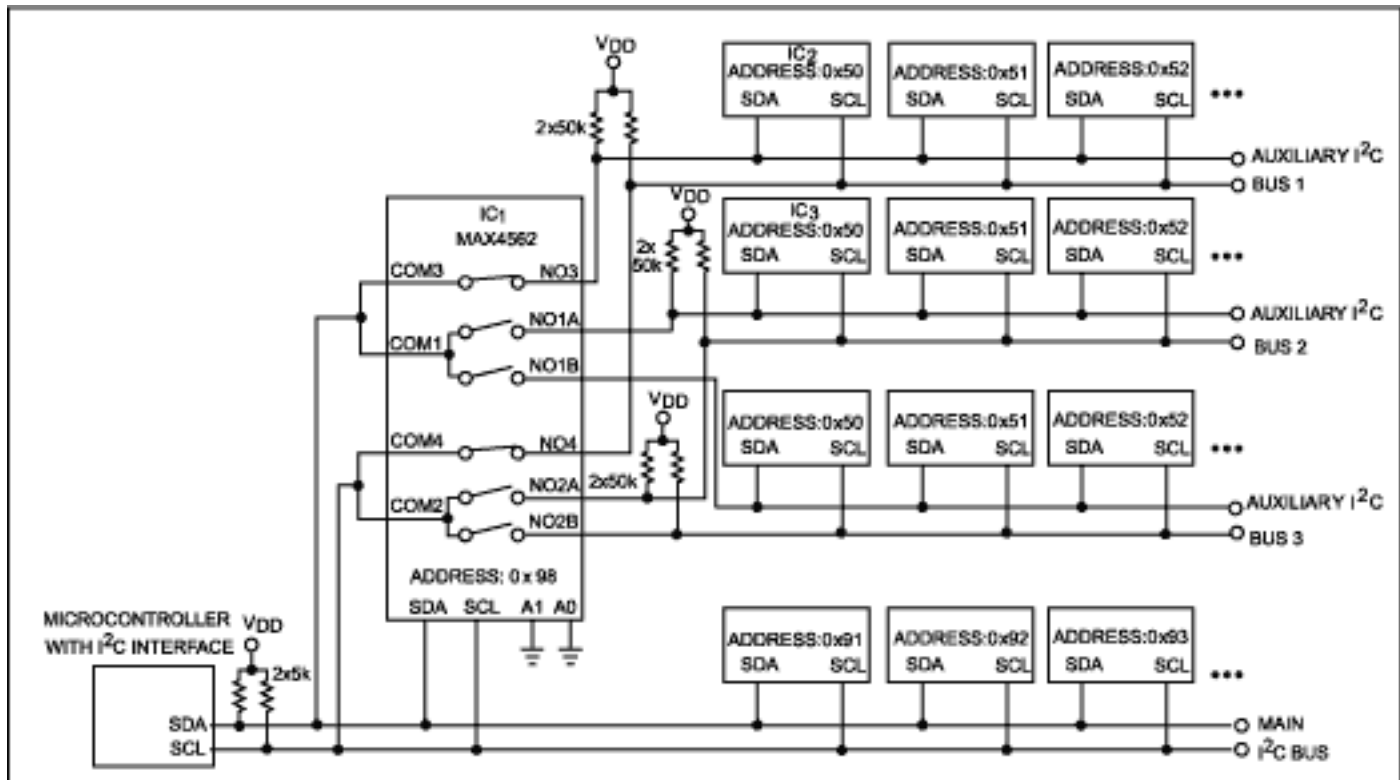

Figure 1. This I<sup>2</sup>C-controlled analog switch expands by three the number of devices connected to the bus.

The arrangement in Figure 1 prevents the master from addressing multiple slaves at the same time. If that situation occurs, the data becomes corrupted during a master-read protocol, and all slaves may not receive data during a master-write protocol. The analog switch accepts bidirectional signals as required for the SDA line. The

switch has low on-state resistance, adds almost no leakage on the lines, and provides four selectable slave addresses. You simultaneously control the switches by using the simple SendByte protocol (address plus 8-bit command).

You can switch the three auxiliary buses on the fly. Power-up sets the switches to soft mode, an off state with 12-msec switching time. Then, a command byte of 0b11000000 sets the switches to hard mode (400-nsec switching time). Subsequent commands select the desired auxiliary bus. Command 0b1000011, for example, selects auxiliary bus 1.

The main I<sup>2</sup>C bus includes necessary pullup resistors, and the auxiliary buses include weaker pullups that ensure a high state when you deselect the bus. The circuit in Figure 1 allows you to add three times more devices on the bus. For a wider selection, you can replace the MAX4562 with a MAX4572, whose 14 switches allow you to add as many as seven auxiliary buses.

A similar version of this article appeared in the November 22, 2001 issue of *EDN* magazine.

---

Application Note 955: <http://www.maxim-ic.com/an955>

### More Information

For technical questions and support: <http://www.maxim-ic.com/support>

For samples: <http://www.maxim-ic.com/samples>

Other questions and comments: <http://www.maxim-ic.com/contact>

### Related Parts

MAX4562: [QuickView](#) -- [Full \(PDF\) Data Sheet](#) -- [Free Samples](#)

MAX4572: [QuickView](#) -- [Full \(PDF\) Data Sheet](#) -- [Free Samples](#)

AN955, AN 955, APP955, Appnote955, Appnote 955

Copyright © by Maxim Integrated Products

Additional legal notices: <http://www.maxim-ic.com/legal>