

APPLICATION NOTE 947

Extend Battery Life with Dual Power Supply for Wallcube/Battery-Powered Systems

Abstract: To save battery life, a dual-output power supply draws battery power only when the AC wallcube source is not present. Featuring the MAX1705 step-up DC-DC converter and either the MAX1524 boost controller or MAX608 step-up DC-DC controller, this dual-output power supply needs no extra diodes or MOSFETs to automatically switch input sources and maintain 5V and 3.3V outputs.

The primary concern for power management in portable equipment is to prolong battery life by eliminating unnecessary energy consumption. The dual-output power supply of Figure 1 supports this objective while maintaining regulated 5V and 3.3V outputs for as long as the battery or AC-wallcube voltage (or both) are present.

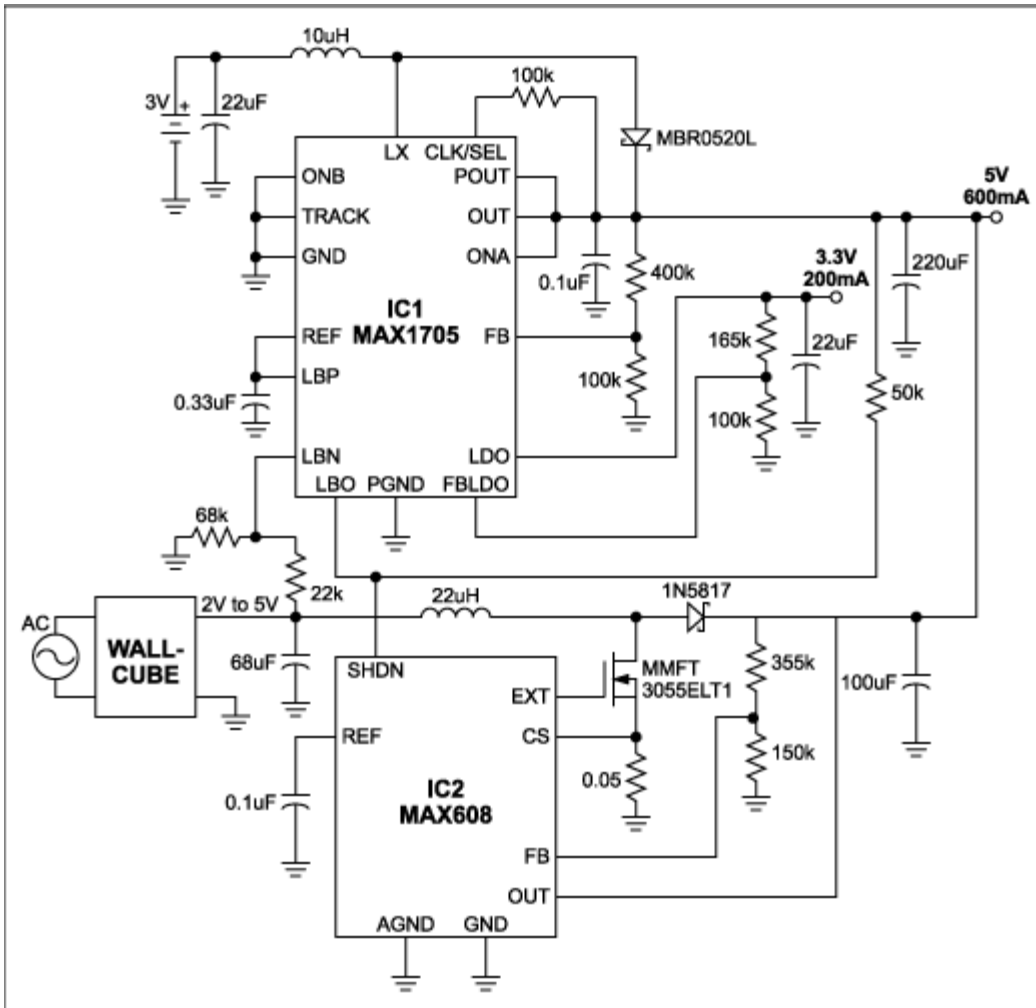

Figure 1. These two ICs switch input sources automatically to maintain 5V and 3.3V outputs.

The circuit draws battery power only when the AC source is not present. Changeover between battery and wallcube requires no user intervention, and the circuit interposes no extra diodes or MOSFETs in the battery path. Its switchmode regulators deliver as much as 600mA at 5V, and its linear regulator delivers as much as 200mA at 3.3V.

IC1, which contains a switchmode regulator and a linear regulator, has separate internal ON/OFF controls that enable its linear

regulator to remain on (powered by IC2's output) when its switching regulator is off. IC2 is a switchmode DC-DC converter that boosts the unregulated wallcube output (2V to 5V) to a regulated output of 5.1V.

IC1's POUT terminal, capable of delivering 300mA at 95% efficiency (and more at slightly reduced efficiency), is set for a regulated output of 5V. Thus, when the wallcube provides a voltage to IC2, IC2 produces a 5.1V output voltage, which causes IC1 to stop switching; in this situation, the voltage fed back to IC1 exceeds the level where IC1 is permitted to switch. IC1 goes into idle mode, drawing less than 1 μ A of quiescent current, until the voltage provided by IC2 drops, allowing IC1 to resume switching. This drop of IC2's output is usually caused when the wallcube is unplugged; when this happens, a comparator in IC1 (LBN/LBO) tells IC2 to shut down. This shutdown prevents a flow of reverse current from IC1's output into IC2's OUT pin.

This circuit can be updated by substituting the MAX1524 and its accompanying external components for the IC2 switching regulator originally used. The MAX1524 comes in a smaller package than the original MAX608 and doesn't require a current-sense resistor.

Related Parts

[MAX1524](#) Simple SOT23 Boost Controllers

[MAX1705](#) 1 to 3 Cell, High Current, Low-Noise, Step-Up DC-DC Converters with Linear Regulator -- [Free Samples](#)

[MAX608](#) 5V or Adjustable, Low-Voltage, Step-Up DC-DC Controller -- [Free Samples](#)

Automatic Updates

Would you like to be automatically notified when new application notes are published in your areas of interest? [Sign up for EE-Mail™](#).

Application note 947: www.maxim-ic.com/an947

More information

For technical support: www.maxim-ic.com/support

For samples: www.maxim-ic.com/samples

Other questions and comments: www.maxim-ic.com/contact

AN947, AN 947, APP947, Appnote947, Appnote 947

Copyright © by Maxim Integrated Products

Additional legal notices: www.maxim-ic.com/legal