

APPLICATION NOTE 926

# Simple Circuit Disconnects Load From Battery

*Abstract: The following application note discusses how to disconnect a load from a depleted battery using the MAX8212 microprocessor voltage monitor. Once the battery is recharged or replaced assert a manual reset to reconnect the load to battery.*

To prevent battery damage, the **Figure 1** circuit disconnects the load at a predetermined level of load voltage. This level ( $V_{TRIP}$ , closely proportional to the battery voltage) is determined by R1 and R2 such that the voltage at pin 3 of IC1 equals 1.15V:  $V_{TRIP} = 1.15V(R1 + R2)/R1$ . The allowed range for  $V_{TRIP}$  is 2V to 16.5V.

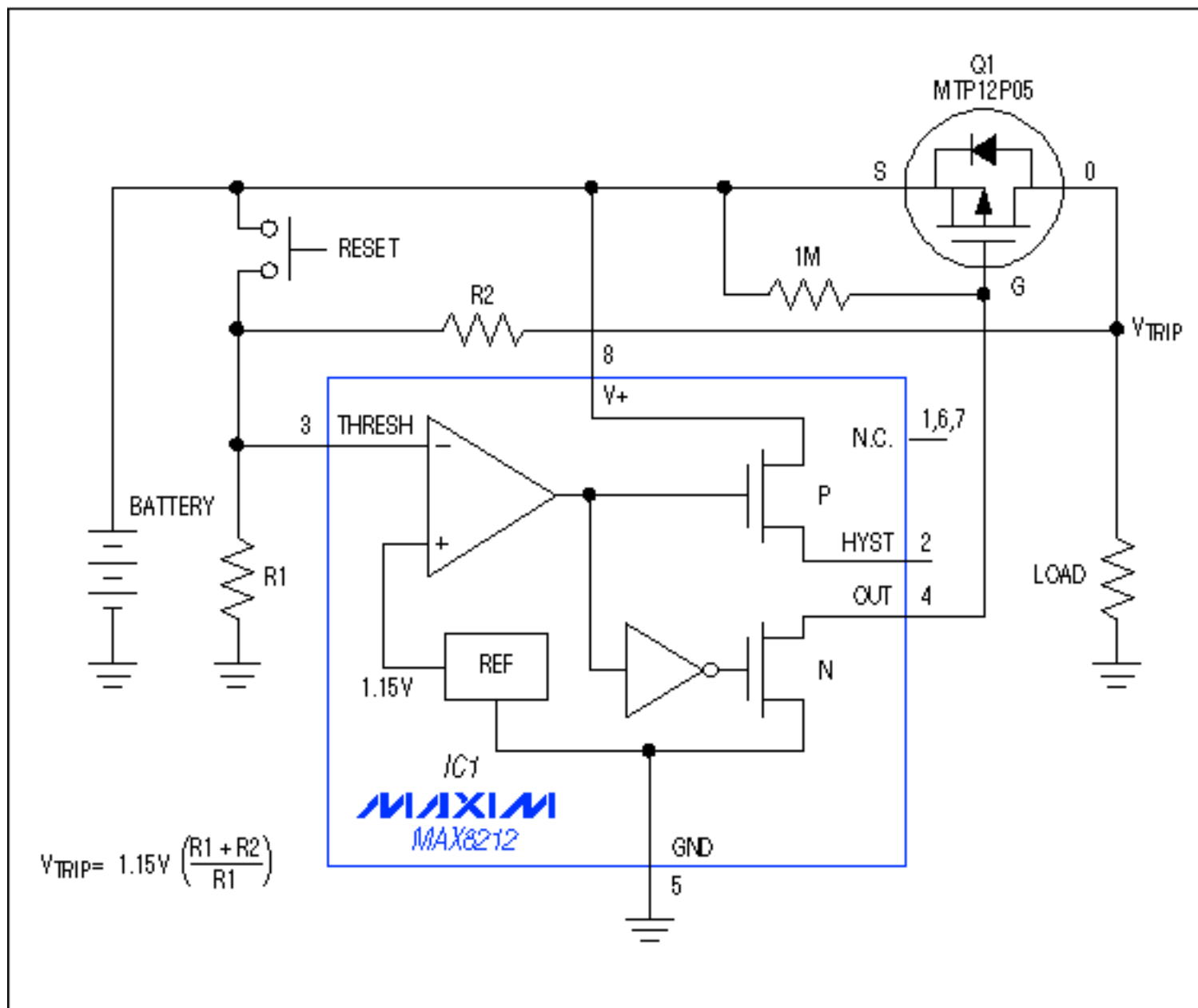

*Figure 1. This circuit disconnects the load and battery (at a level of battery voltage determined by R1 and R2) and remains latched in that state until reset by the pushbutton switch.*

The load-battery connection remains open until the system receives a manual reset command. Automatic reconnect circuitry is not always desired, and in any case it may not be effective because the battery voltage rises so much when the load is removed. If the load must be removed before full discharge, or if the difference in terminal voltage from charge to discharge is small, then the hysteresis required (including the effects of component tolerance) may be too great to ensure an automatic reconnection after the battery is recharged or replaced.

Pressing Reset (or pulling pin 3 above 1.15V with a transistor) reconnects the load after the battery is recharged or replaced. Battery drain with the load disconnected is only 5 $\mu$ A, so the circuit can remain in that state for an extended period without causing a deep discharge of the battery. Choose Q1 for a minimal voltage drop (source to drain) at the required load current.

*A related idea appeared in the 3/14/96 issue of EDN.*

---

Application Note 926: <http://www.maxim-ic.com/an926>

### **More Information**

For technical questions and support: <http://www.maxim-ic.com/support>

For samples: <http://www.maxim-ic.com/samples>

Other questions and comments: <http://www.maxim-ic.com/contact>

### **Related Parts**

MAX8212: [QuickView](#) -- [Full \(PDF\) Data Sheet](#) -- [Free Samples](#)

AN926, AN 926, APP926, Appnote926, Appnote 926

Copyright © by Maxim Integrated Products

Additional legal notices: <http://www.maxim-ic.com/legal>