



APPLICATION NOTE 919

Upconverter-Driver for US CDMA Delivers +3dBm at -59dBc/-73dBc ACPR for 30mA

Additional Information:

- [Wireless Product Line Page](#)
- [Quick View Data Sheet for the MAX2307](#)
- [Applications Technical Support](#)

The MAX2307 is an integrated RF upconverter-driver in an ultra-small 3 x 4 UCSP package (1.5mm x 2.0mm). Although the MAX2307 was originally characterized for Japanese CDMA, this application demonstrates its performance when tuned for US CDMA transmit frequencies between 824MHz to 849MHz. With an IF frequency of 130.38MHz, the MAX2307 delivers +3dBm of output power over the 824 to 849MHz frequency range while exceeding ACPR requirements by several dB. Current consumption at +3dBm is 30mA from a supply voltage of +3.0V. A low-power logic-controlled shutdown allows supply current to be reduced to under 1mA.

A few component changes are required to the MAX2307 EV kit to tune it for an IF frequency of 130.38MHz, and the RF frequency range of 824 to 849MHz. See **Figure 1** for the schematic and Table 1 for the component description.

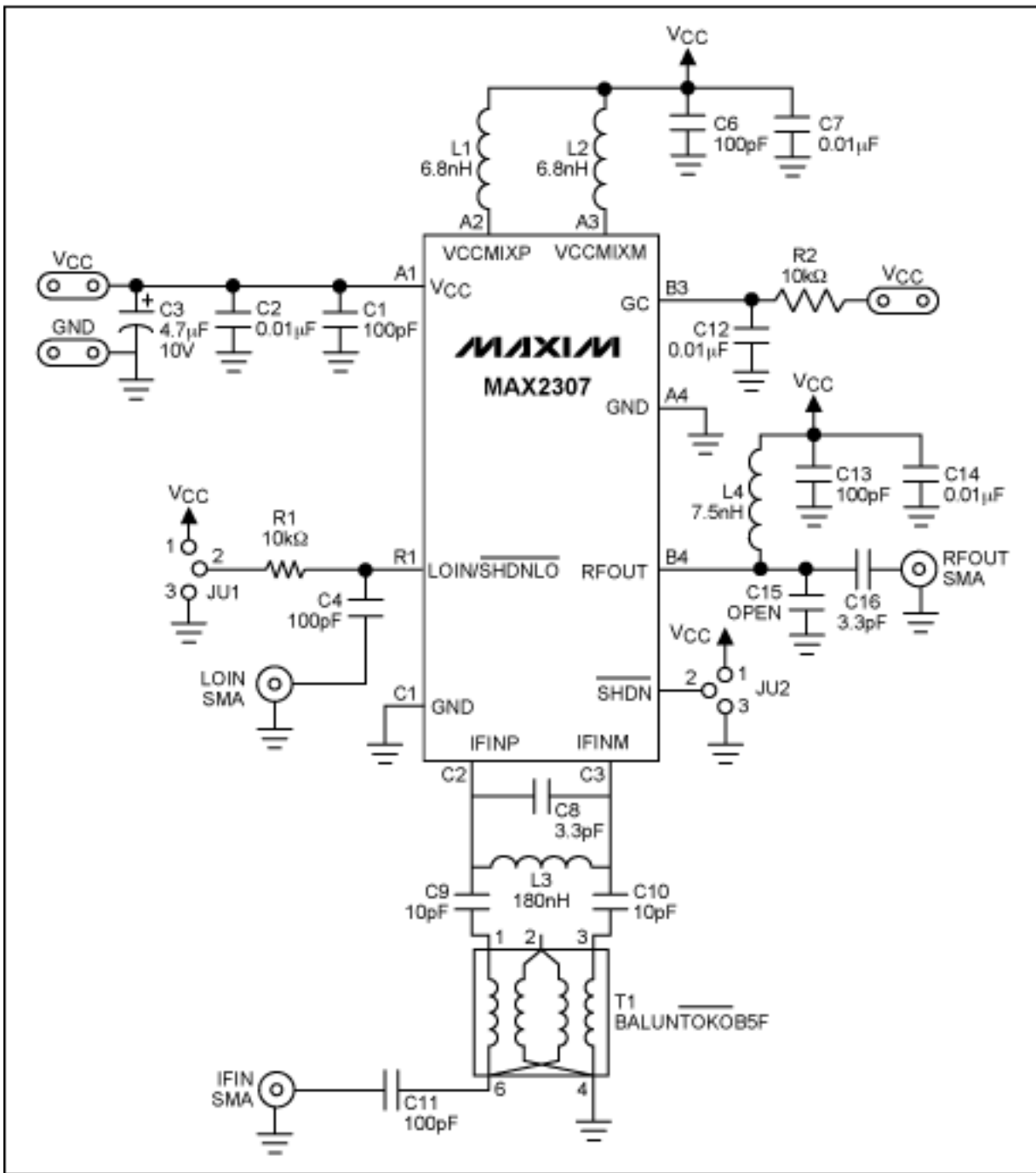

Figure 1. The MAX2307 for US CDMA with 130MHz IF.

Table 1. The MAX2307 for US CDMA with 130MHz IF

Designation	Quantity	Description
C1, C4, C6, C11, C13	5	100pF 5% ceramic capacitors (0402) Murata GRM36COG101J050
C15	2	Not installed
C16	1	3.3pF ceramic capacitor (0402) Murata GRM36COG3R3B050
C3	1	4.7 μ F A Case 10V AVXTAJA475M010
C2, C7, C12, C14	4	0.01 μ F 10% ceramic capacitors (0402) Murata GRM36X7R103K016
C8	1	3.3pF \pm 0.1pF ceramic capacitor (0402) Murata GRM36COG3R3B050
C9, C10	2	10pF \pm 0.25pF ceramic capacitor (0402) Murata GRM36COG100C050
L1, L2	2	6.8nH inductors (0402) Murata LQG10A6N8S00
L3	1	180nH inductor (0603) Coilcraft 0603CS-18XJBC
L4	1	7.5nH inductor (0402) Murata LQP10A7N5B00
R1, R2	2	10k Ω 5% resistors (0402)
T1	1	Balun transformer (B5F type) Toko 458DB-1011
RF_OUT, LOIN, IFIN	3	SMA connectors (PC-edge-mount) EF Johnson 142-0701-801 or Digi-Key J502-ND
JU1, JU2	2	3-pin headers
VCC, GND, VGC	3	Test points Mouser 151-203
U1	1	MAX2307EBC (UCSP-4x3L)
None	1	MAX2307 PC board
None	1	MAX2307 data sheet
None	1	MAX2307 EV Kit data sheet

Figures 2 and 3 demonstrate the gain and ACPR performance of the device over frequency.

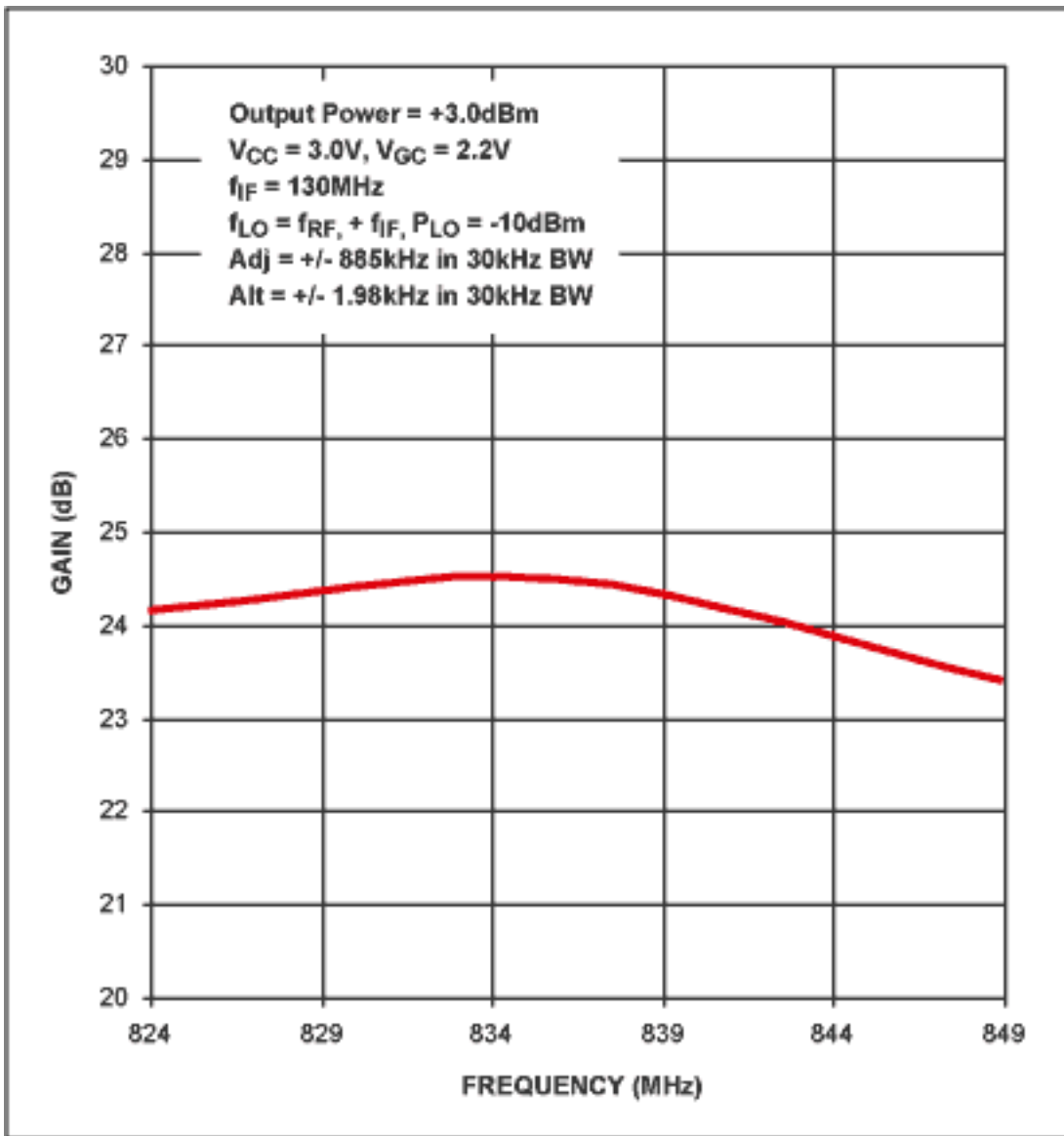

Figure 2. The MAX2307 gain vs. frequency.

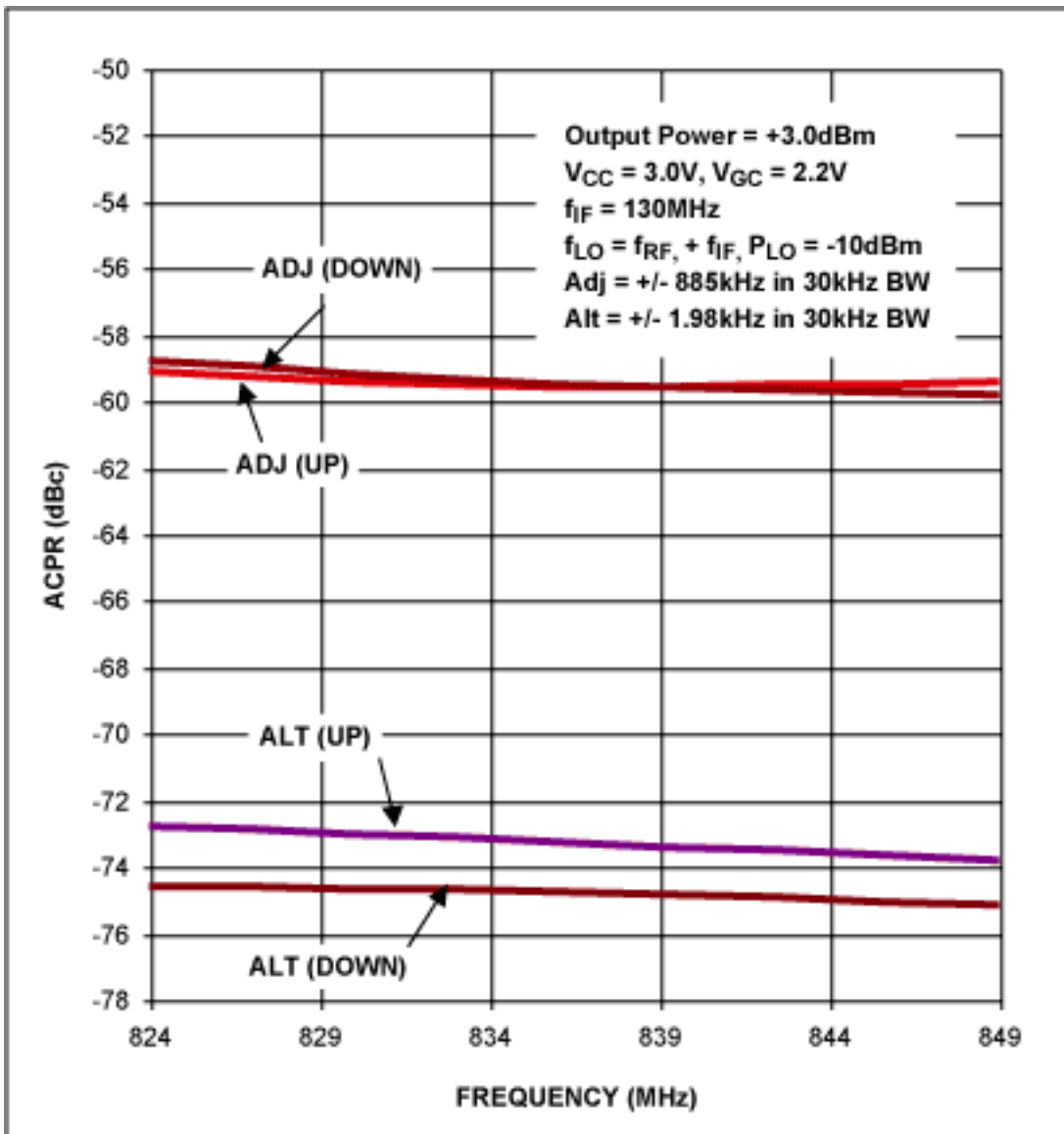

Figure 3. The MAX2307 ACPR vs. frequency.

Figure 4 demonstrates the output power and ACPR performance vs. gain control voltage.

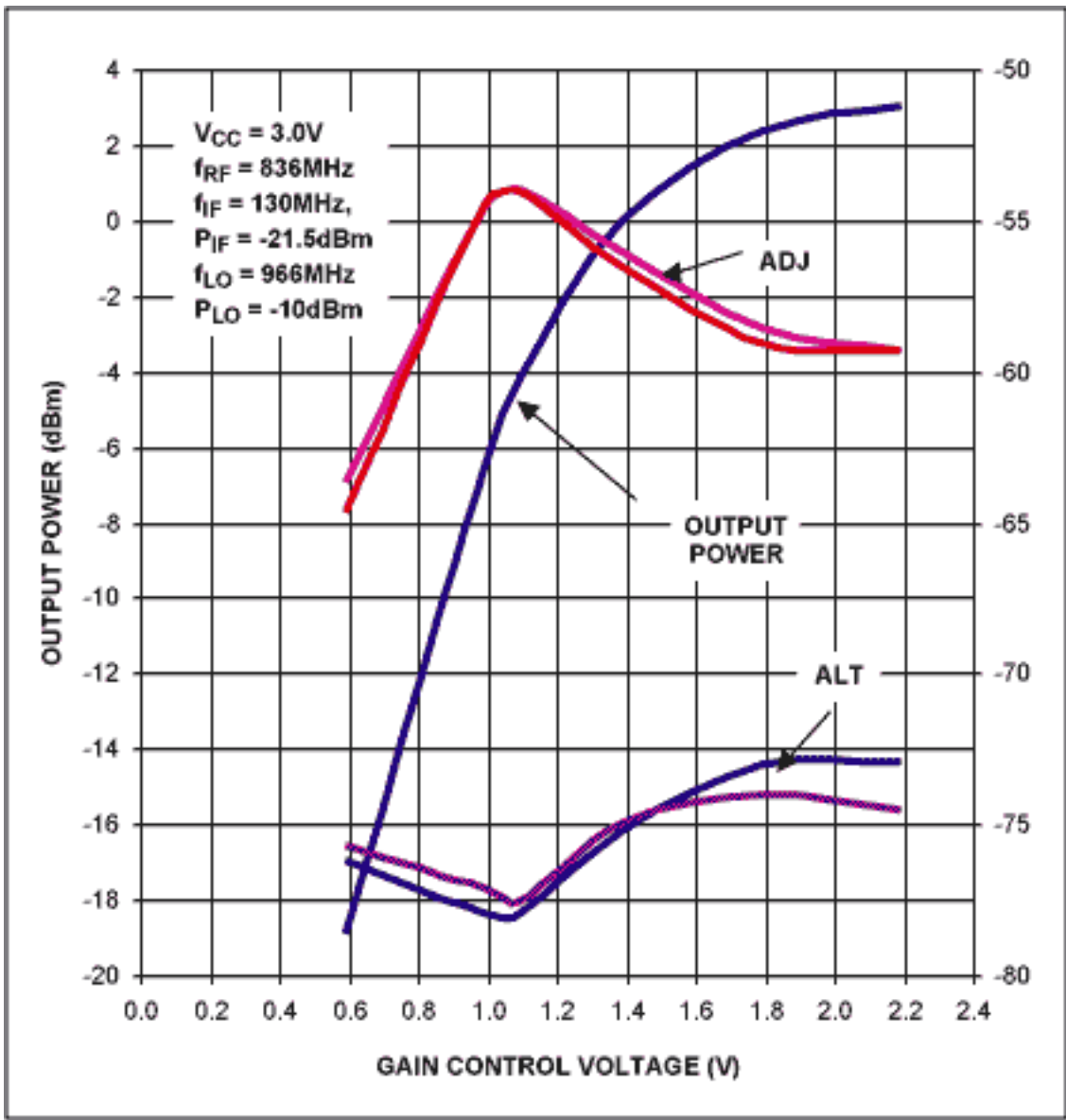

Figure 4. The MAX2307 output power and ACPR vs. gain control voltage.

Figure 5 demonstrates output power and ACPR performance vs. input power.

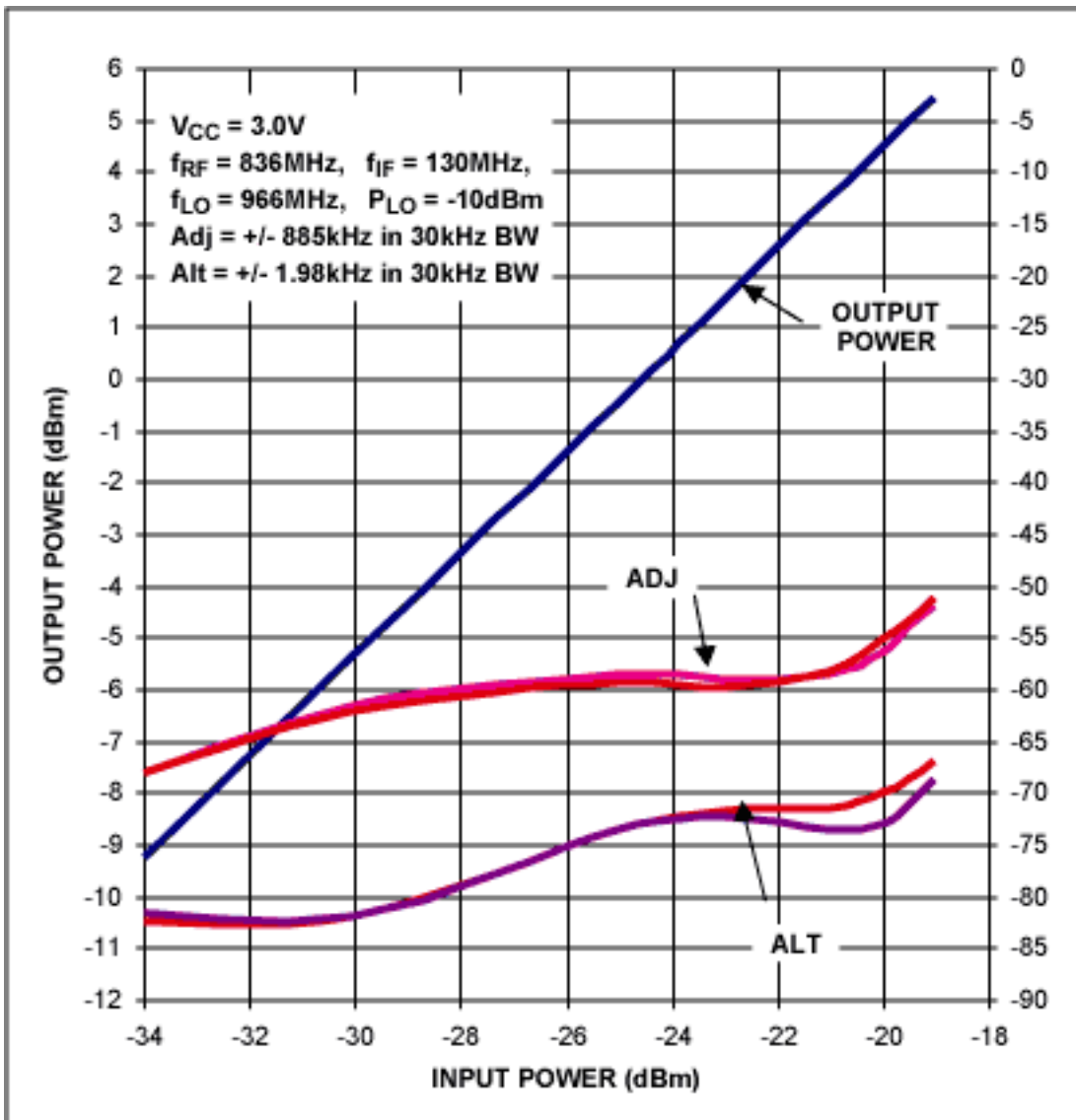

Figure 5. The MAX2307 output power and ACPR vs. input power.

Figure 6 demonstrates supply current vs output power.

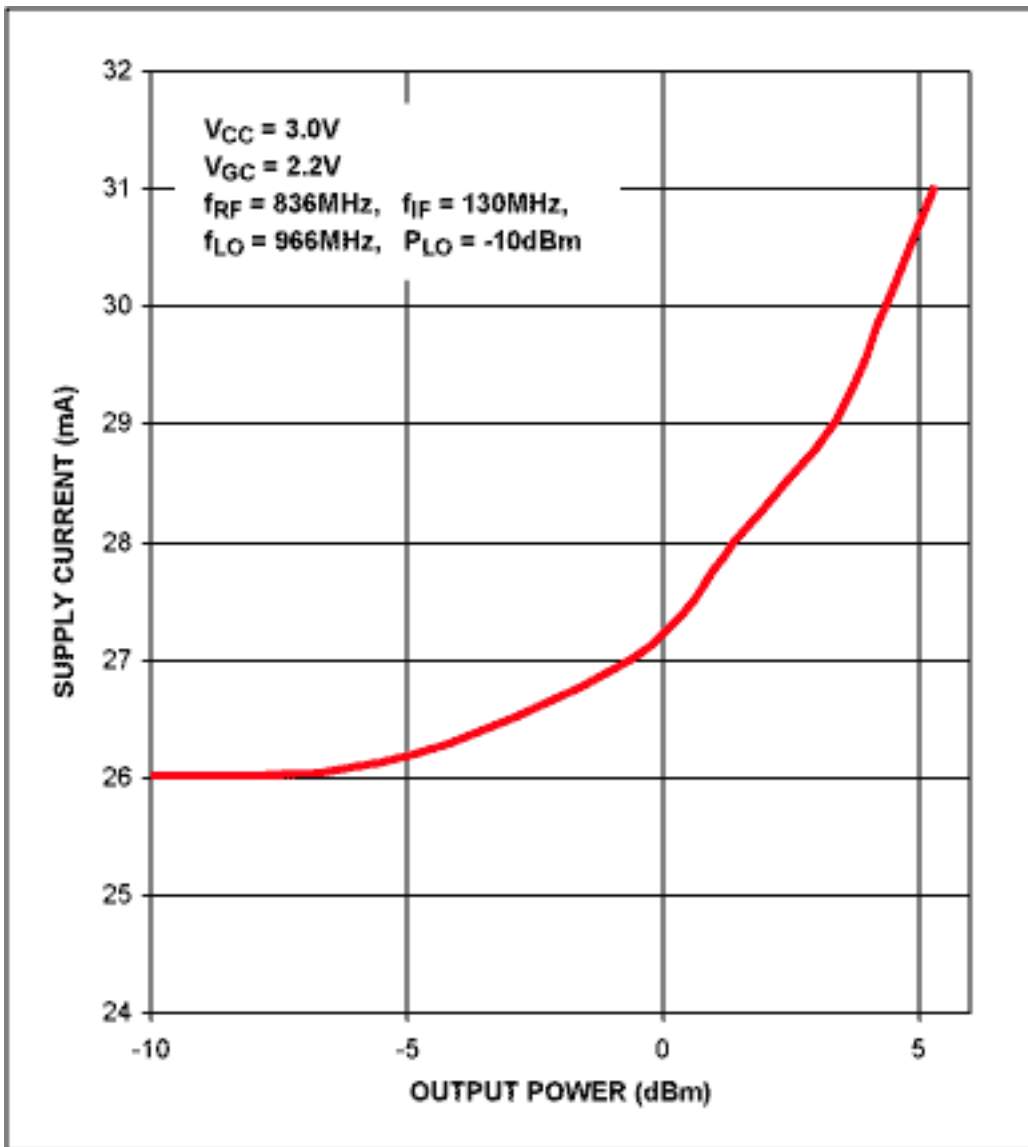

Figure 6. The MAX2307 supply current vs. output power.

Additionally the MAX2307 provides 18dBc of image-suppression, relative to the desired tone, and -36dBc of carrier suppression. See the [MAX2307 data sheet](#) and [MAX2307 EV kit data sheet](#) for further performance information and pcb layout information.

Application Note 919: <http://www.maxim-ic.com/an919>

More Information

For technical questions and support: <http://www.maxim-ic.com/support>

For samples: <http://www.maxim-ic.com/samples>

Other questions and comments: <http://www.maxim-ic.com/contact>

Related Parts

MAX2307: [QuickView](#) -- [Full \(PDF\) Data Sheet](#)

AN919, AN 919, APP919, Appnote919, Appnote 919

Copyright © by Maxim Integrated Products

Additional legal notices: <http://www.maxim-ic.com/legal>