

APPLICATION NOTE 910

High-Efficiency Boost Converter Provides 24V for DTE

Data terminal equipment (DTE), such as wireless LAN and wireless local loop, may require data and power on the same cable. A high voltage power source of 24V is required to reduce the voltage drop in the cable.

Isolation is provided by the 12V power-supply. For a system with one or two ports, a custom-designed DC-DC converter is more suitable than power modules, or "bricks", since bricks tend to be bulkier and are more expensive. They are more suitable for systems that support more ports, where the power demand is higher.

The MAX668 is an excellent choice for the design of a DC-DC step-up converter. The MAX668, a current-mode controller, operates in the PWM mode at medium and heavy loads, providing high-efficiency and low-noise. With power levels greater than 20W, efficiencies of more than 90% are achievable.

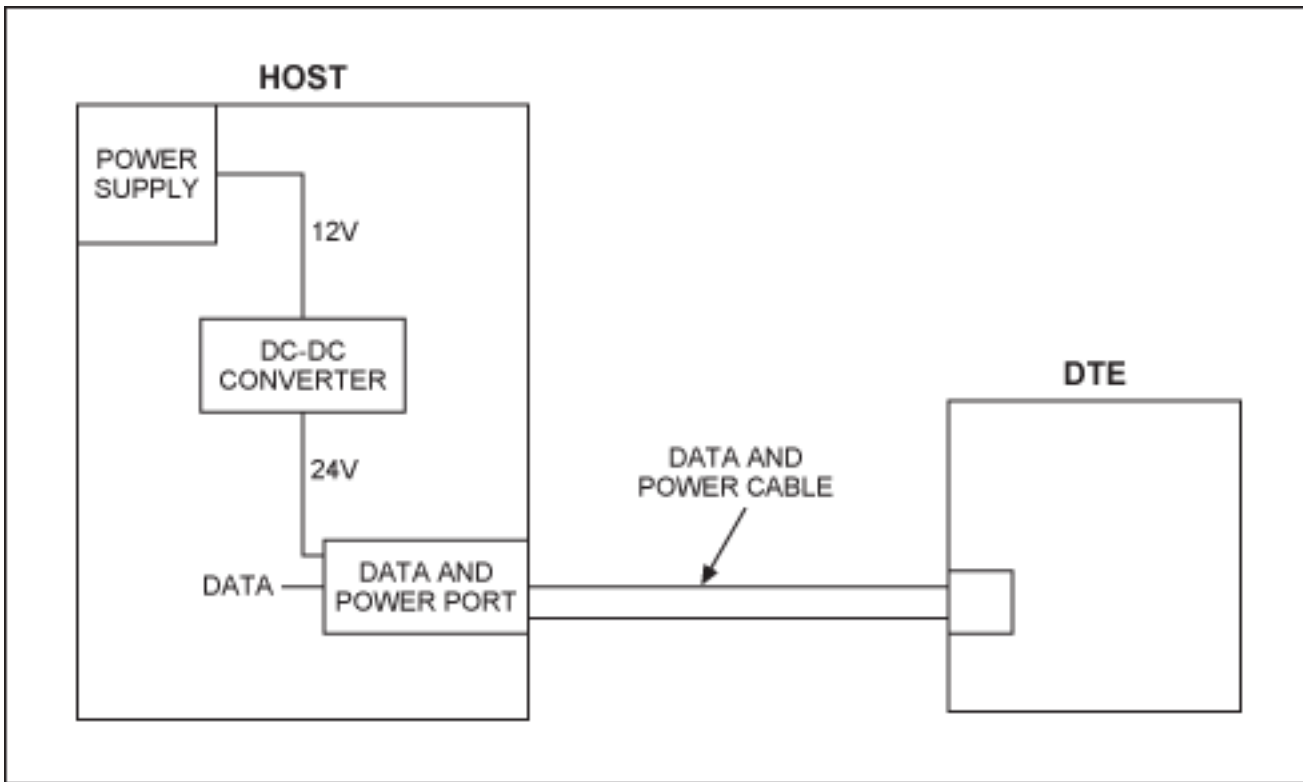

Figure 1.

The circuit of **Figure 2** has a 24V output and can deliver current up to 3 amperes, enough to power a system with two ports. A switching frequency of 500kHz was chosen as a compromise between switching loss and the size of inductor L1. Increasing the value of gate resistance R7 will reduce EMI noise, but increase switching loss. A value of 4.7Ω was chosen as a compromise. At an input voltage of 12V, a full load of 3 amperes and an output of 24V, the conversion efficiency was 93%.

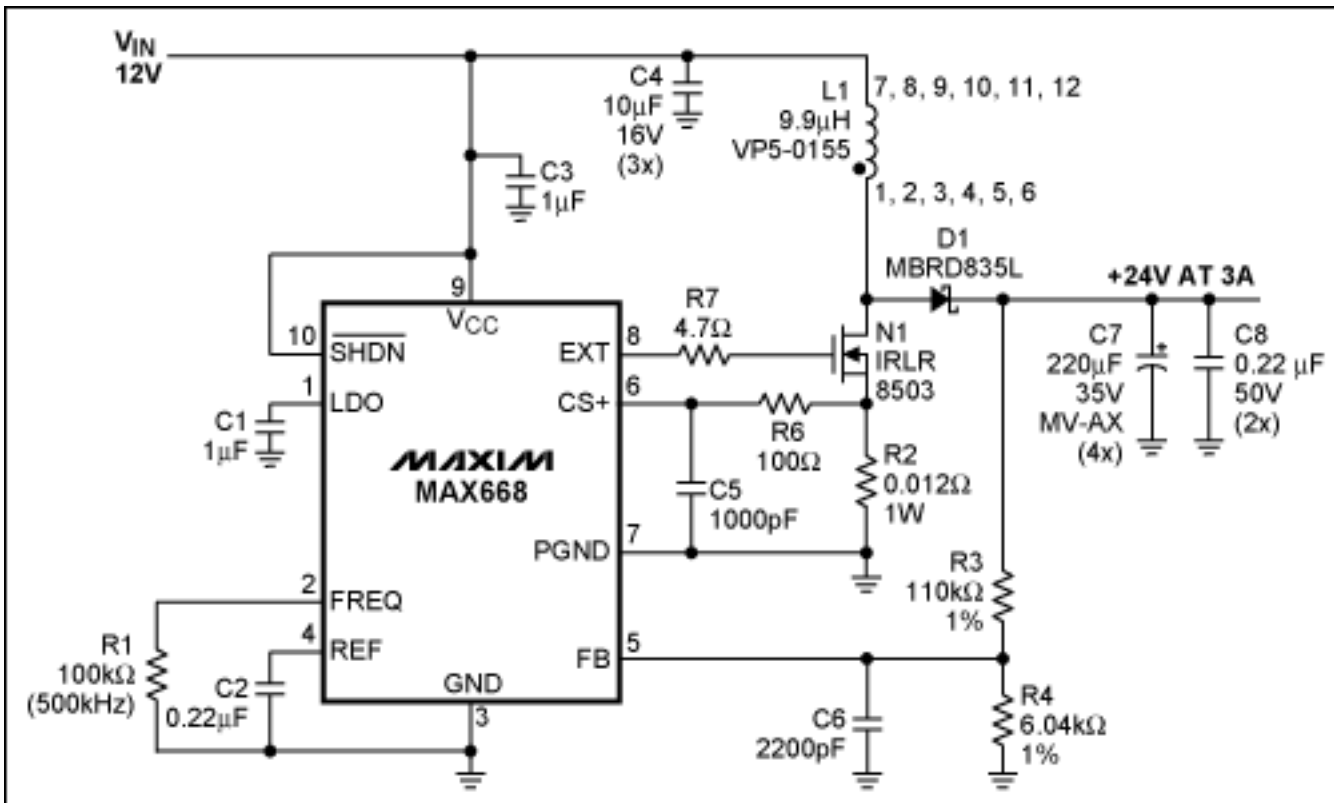

Figure 2.

Application Note 910: www.maxim-ic.com/an910

More Information

For technical support: www.maxim-ic.com/support

For samples: www.maxim-ic.com/samples

Other questions and comments: www.maxim-ic.com/contact

Automatic Updates

Would you like to be automatically notified when new application notes are published in your areas of interest? [Sign up for EE-Mail™.](#)

Related Parts

MAX668: [QuickView](#) -- [Full \(PDF\) Data Sheet](#) -- [Free Samples](#)

AN910, AN 910, APP910, Appnote910, Appnote 910

Copyright © by Maxim Integrated Products

Additional legal notices: www.maxim-ic.com/legal