

APPLICATION NOTE 909

The MAX1802 for Digital Still Camera from 2AA Batteries

Digital camera supplies must be small and efficient. The power supplies must be relatively free of low-power noise, so that post filtering can be easily achieved. They must be capable of generating several voltages. Most camera makers require 4 to 6 channels for power supplies. A typical block diagram of a digital still camera (DSC) indicating the different power supply channels is shown in **Figure 1**.

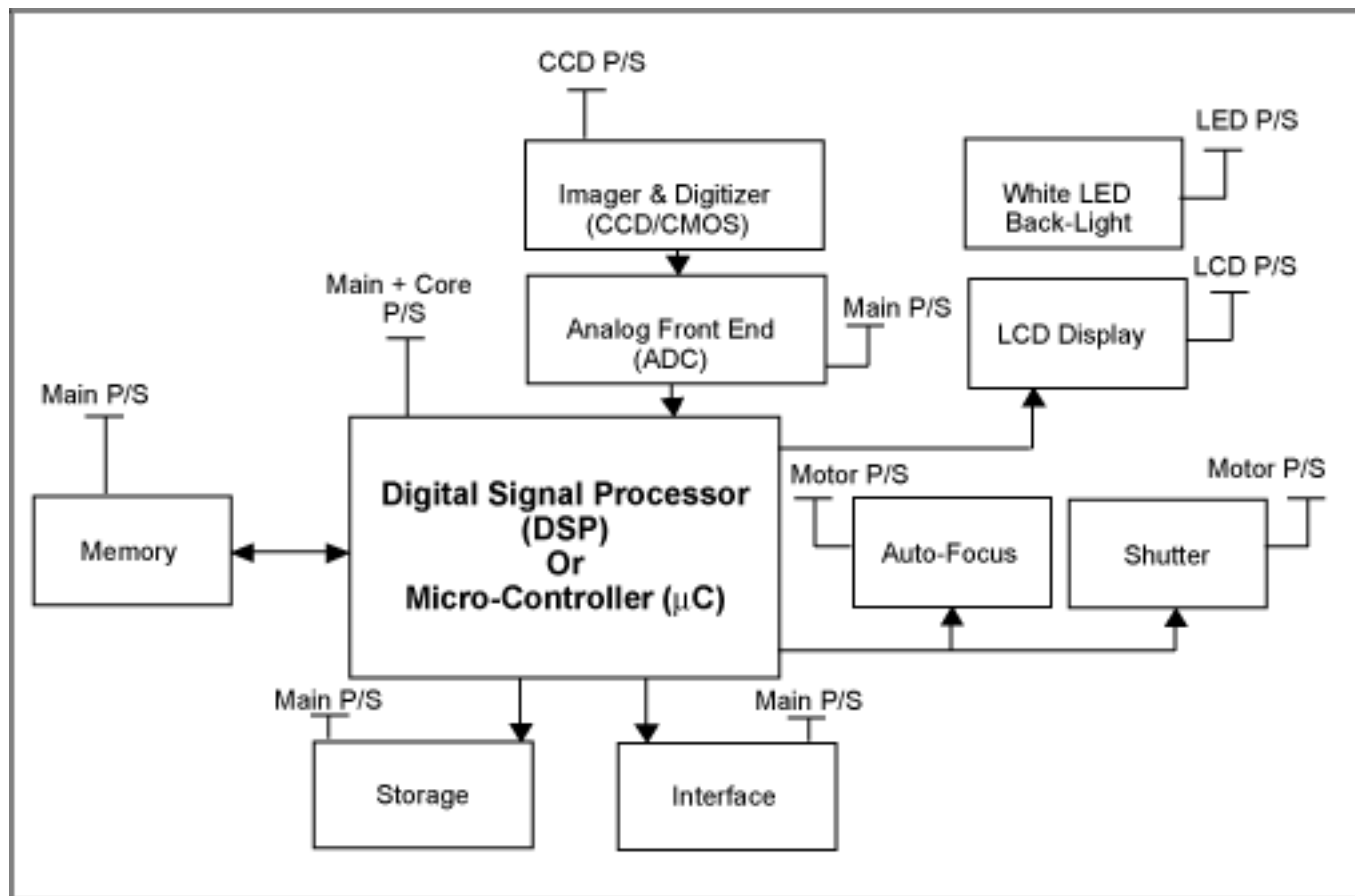

Figure 1. Block diagram of a typical digital still camera.

Most of the DSC systems also have a sub-processor (not shown in Figure 1), which contains a real-time clock and memory controller. The sub-processor is powered by an always-on back-up supply to keep the sub-processor blocks alive during system shutdown. Some manufacturers prefer that this supply be separated from the main battery supply to save battery life. In such systems an additional converter is necessary to provide the always-on backup power supply to the sub-processor.

The MAX1802 provides a complete single chip solution for powering the major blocks in digital still cameras and video cameras by integrating a high-efficiency step-down controller and converter each, and three auxiliary step-up controllers. The step-down controller is typically used for the main system power supply and the converter as the core power supply. The three auxiliary controllers are used for the LCD, CCD and motor power supplies. The MAX1801 is a slave controller that can be used with the MAX1802 to generate an independent LED power supply, if necessary. The MAX1802 operates in a low-noise constant frequency PWM mode and the MAX1801 is synchronized to the MAX1802 oscillator.

VDDM (used as main system supply) and 1.5V output step-down converter (used for core processor power) through VDDC (Figure 2). The efficiency for this circuit at different loads and input voltages is shown in **Figure 3**.

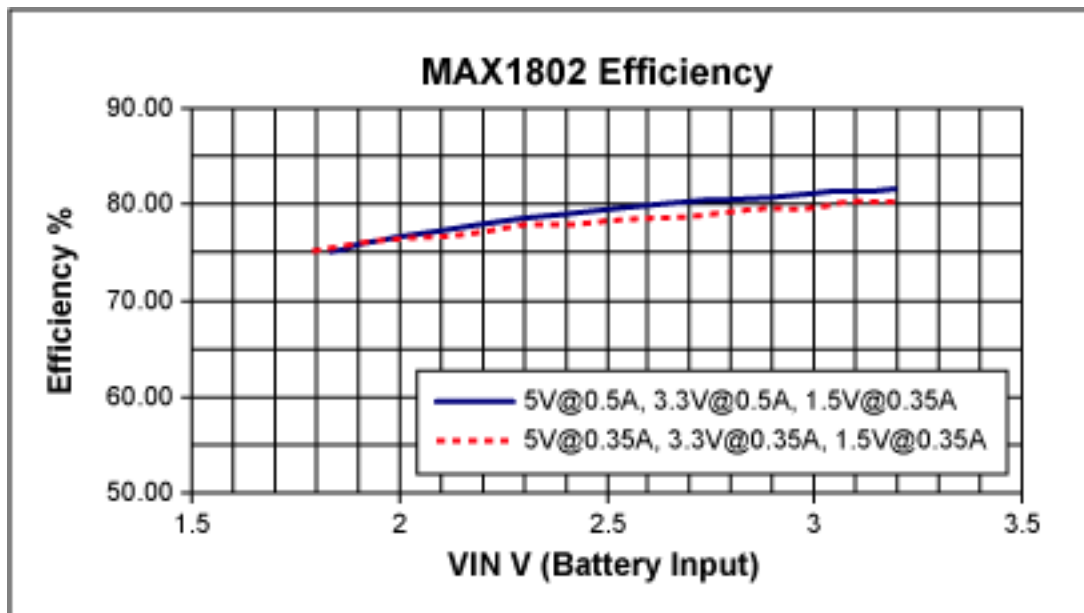

Figure 3. Efficiency curve for the MAX1802 with 2AA cell input.

This data indicates that the MAX1802 is an efficient solution for a portable system power supply where component count and board real estate are critical issues even when the input voltage is lower than the range specified in the [MAX1802 data sheet](#).

Application Note 909: <http://www.maxim-ic.com/an909>

More Information

For technical questions and support: <http://www.maxim-ic.com/support>

For samples: <http://www.maxim-ic.com/samples>

Other questions and comments: <http://www.maxim-ic.com/contact>

Related Parts

MAX1802: [QuickView](#) -- [Full \(PDF\) Data Sheet](#) -- [Free Samples](#)

AN909, AN 909, APP909, Appnote909, Appnote 909

Copyright © by Maxim Integrated Products

Additional legal notices: <http://www.maxim-ic.com/legal>