



APPLICATION NOTE 905

Adding POR Function to the MAX1864 Generating Two Outputs

The MAX1864 power-supply controller is designed for cost-effective applications such as cable modem consumer premise equipment (CPE), XDSL CPE and set-top boxes. It includes a current mode synchronized step-down controller and two positive regulator gain blocks.

This chip does not have a power-on-reset (POR) function. This application note demonstrates how to add this function, using one of the linear regulator controllers to reset the microprocessor 140ms after the output voltage is within the regulated output voltage.

Figure 1 shows the circuit schematic. POR is used to monitor the main output, VOUT1. When the main output, VOUT1, reaches its specified output voltage, POR becomes active-high with 140ms delay. The synchronized buck and one positive regulator gain block (B2 and FB2) controller in the MAX1864 provide two outputs, while the second regulator gain block (B3 and FB3) monitors the main output voltage. A resistor, R6, is connected between the output, VOUT1 and FB3, and a capacitor, C6, is connected from the FB3 pin to ground. A pull-up resistor, R5, is connected to the supply voltage (+5V) through B3, and the output from B3 can be used as the POR output. When the output, VOUT1, is within the regulated range, the voltage at the FB3 pin gradually increases by charging the capacitor, C6, through the output, VOUT1. The voltage across C6 is dependent on the time constant of R6 and C6. With the values shown for R6 and C6, POR will become high 140ms after the time where the voltage at the FB3 pin is high enough.

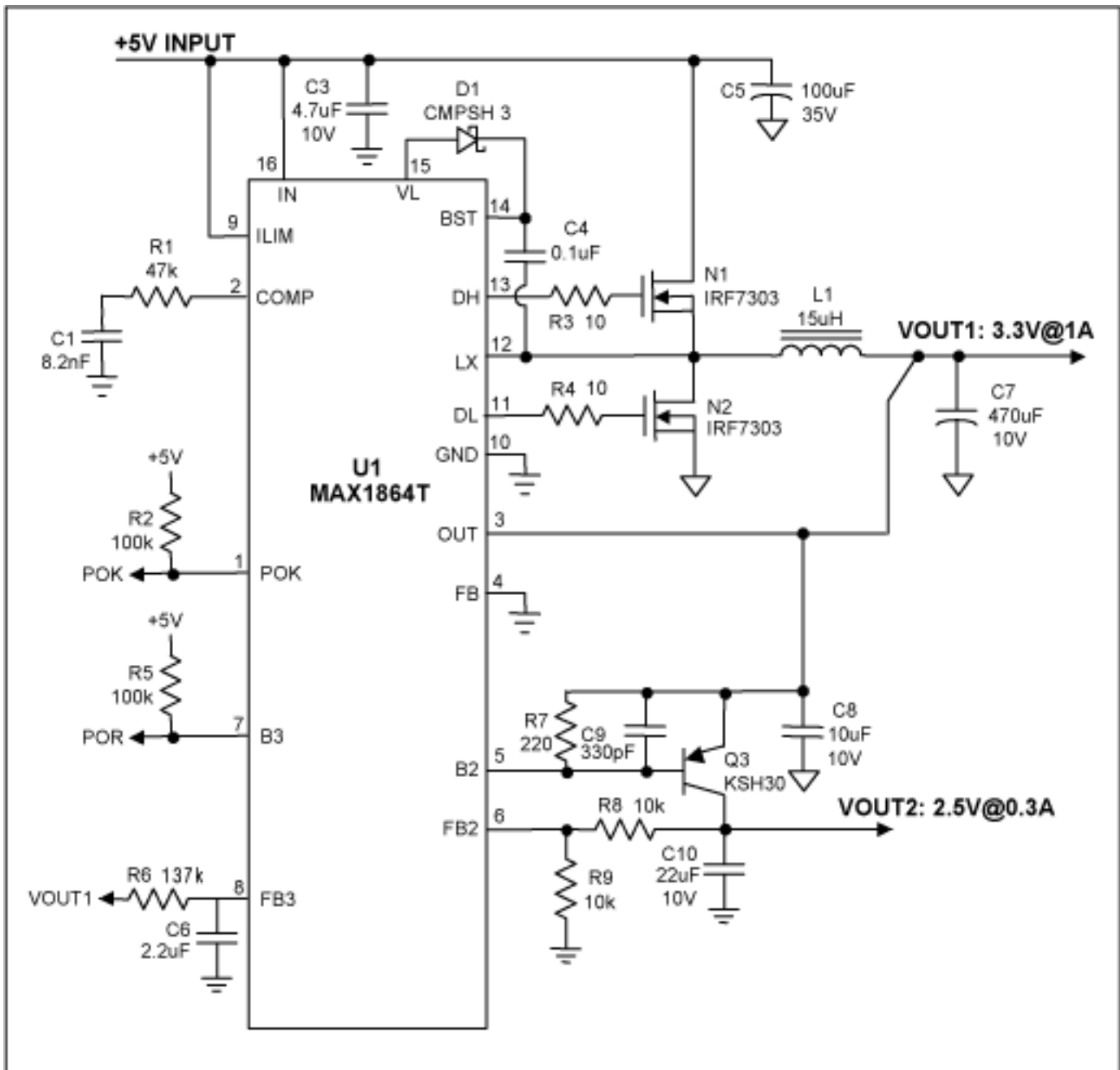

Figure 1. Two output with POR function.

Figure 2 shows the POR and VOUT1 waveforms.

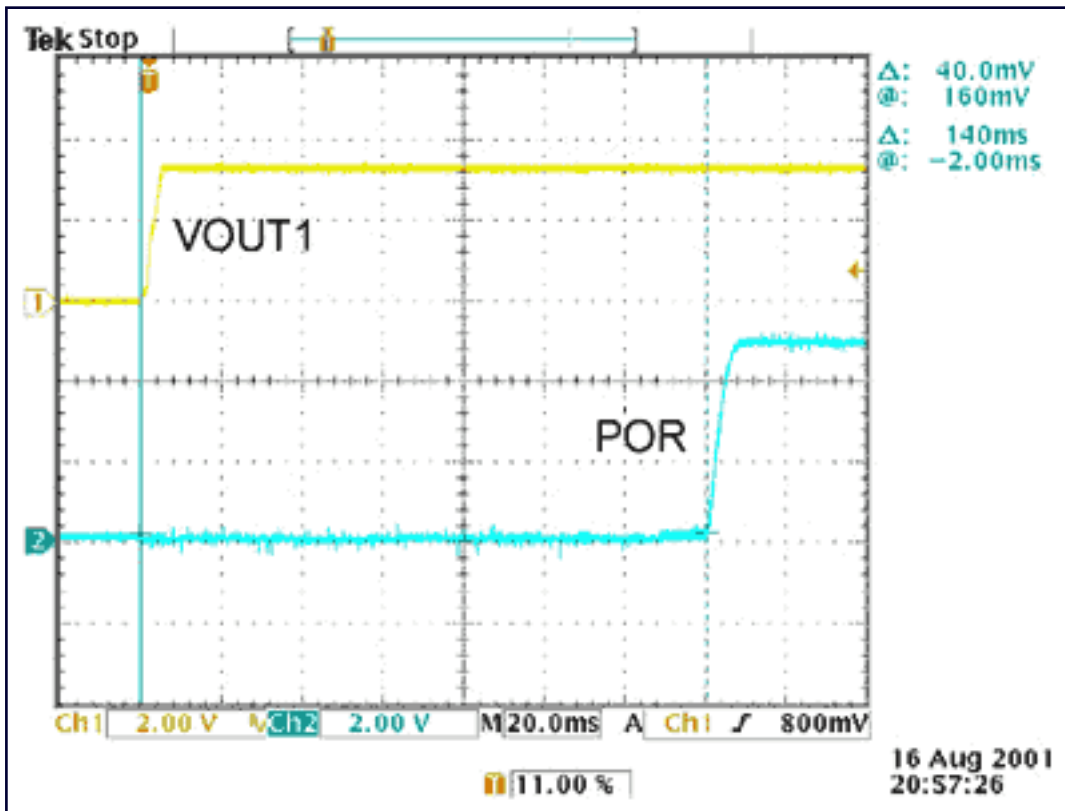

Figure 2. Experimental waveforms.

Application Note 905: <http://www.maxim-ic.com/an905>

More Information

For technical questions and support: <http://www.maxim-ic.com/support>

For samples: <http://www.maxim-ic.com/samples>

Other questions and comments: <http://www.maxim-ic.com/contact>

Related Parts

MAX1864: [QuickView](#) -- [Full \(PDF\) Data Sheet](#) -- [Free Samples](#)

AN905, AN 905, APP905, Appnote905, Appnote 905

Copyright © by Maxim Integrated Products

Additional legal notices: <http://www.maxim-ic.com/legal>