

APPLICATION NOTE 90

Negative-Output Boost Regulator Has High Efficiency

Abstract: In this design note a switching regulator, the MAX634, operates with a charge pump to produce an adjustable, regulated, negative output voltage with high efficiency. The circuit converts 5V to an adjustable negative output of -12V to -22V for use as a backplane bias supply for LCDs.

The circuit of Figure 1 converts 5V to an adjustable output of -12V to -22V, suitable for use as a backplane-bias supply for LCDs. The circuit includes a switching regulator that boosts the input voltage to a high positive voltage (top of Q3), and a charge pump that converts this level to the negative output voltage. The scheme provides good load regulation and allows use of an economical, low-side, n-channel MOSFET switch (Q3). Efficiency (90% or so for the entire output range) surpasses that of most inverting-topology converters (Figure 2).

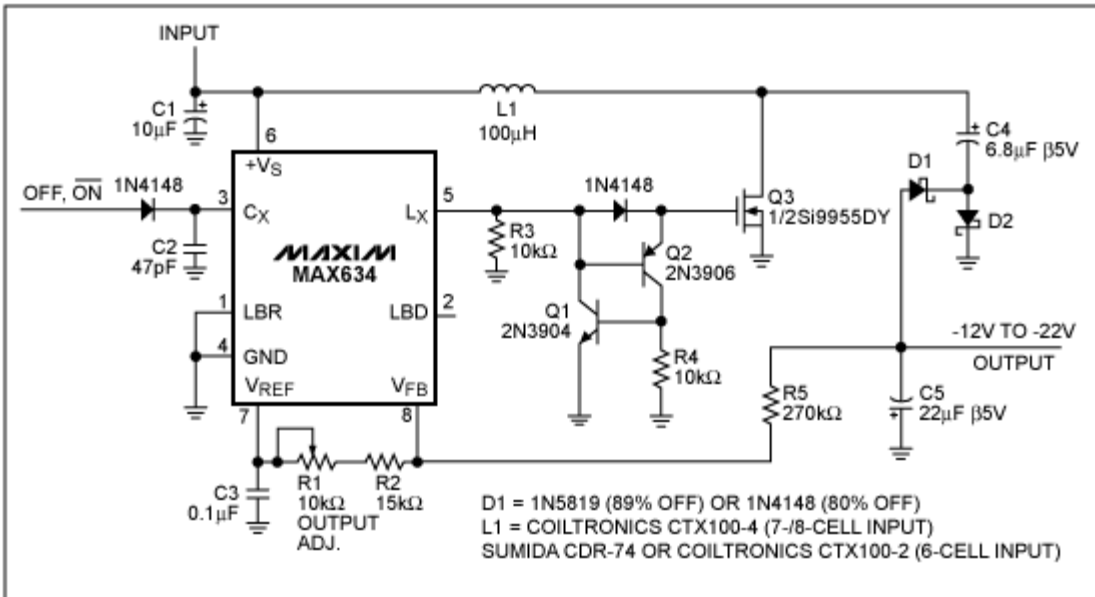

Figure 1. This switching regulator operates with a discrete-component charge pump (D1, D2, C4, and C5) to produce an adjustable, regulated, negative output voltage.

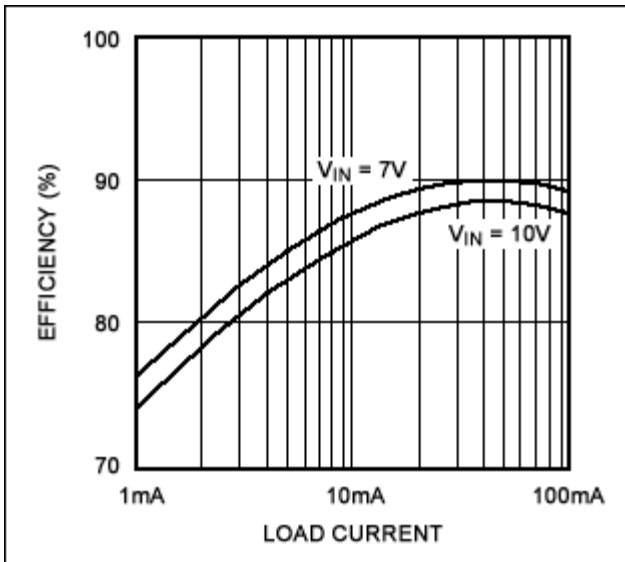

Figure 2. The Figure 1 circuit exhibits excellent efficiency at higher load currents.

Q1 and Q2 form an SCR that turns on as the internal power switch (between the VS and LX terminals) turns off. The SCR action discharges the gate capacitance of Q3 so it can turn off quickly. Potentiometer R1 adjusts the output voltage.

If battery voltage exceeds the absolute value of output voltage, the output does not track the input as a normal boost regulator would do. Instead, the charge pump and feedback loop maintain the the correct output value, the cost being high noise and low efficiency (lower than that of an equivalent linear regulator).

Related Parts

[MAX634 CMOS, Micropower, Inverting Switching Regulator](#) -- [Free Samples](#)

Automatic Updates

Would you like to be automatically notified when new application notes are published in your areas of interest? [Sign up for EE-Mail™](#).

Application note 90: www.maxim-ic.com/an90

More information

For technical support: www.maxim-ic.com/support

For samples: www.maxim-ic.com/samples

Other questions and comments: www.maxim-ic.com/contact

AN90, AN 90, APP90, Appnote90, Appnote 90

Copyright © by Maxim Integrated Products

Additional legal notices: www.maxim-ic.com/legal