

Design Note:

**HFDN-18.0**

Rev.1; 04/08

---

---

**The MAX3865 Laser Driver with Automatic  
Modulation Control**

---

---



*Maxim Integrated Products*

# The MAX3865 Laser Driver with Automatic Modulation Control

## 1 Introduction

Laser diodes for telecommunication applications are characterized by two principal parameters:

- The *threshold current*,  $I_{th}$ , which can be defined as the minimum current through the laser diode that will support stimulated emission of photons (resulting in coherent optical output). Laser current levels below the threshold current result in low-level spontaneous emission (non-coherent optical output). See Figure 1.
- The *slope efficiency*,  $S$ , is the gradient of optical power output versus current input above the threshold as defined in Equation (1).

$$S = \frac{d(\text{optical power output})}{d(\text{laser input current})}. \quad (1)$$

In actual use, the maximum and minimum drive currents,  $I_{max}$  and  $I_{min}$ , should be chosen so that the average optical power output,  $P_{av}$ , (see Equation (2)) is adequate for the application, and so that the extinction ratio,  $r_e$ , (Equation (3)) is as large as possible:

$$P_{av} = \frac{P_{max} + P_{min}}{2} \quad (2)$$

$$r_e = \frac{P_{max}}{P_{min}}. \quad (3)$$

Attempting to obtain a large but controlled extinction ratio is ultimately the source of many problems with practical laser drivers. On the one hand the laser must never operate below the threshold current, because this will cause an unpredictable start-up delay and a poor waveform (due to relaxation oscillation), in addition to increased noise and degraded laser spectral properties (“chirp”). On the other hand, laser characteristics are somewhat variable from one to the next, and in any case they vary with temperature and age.

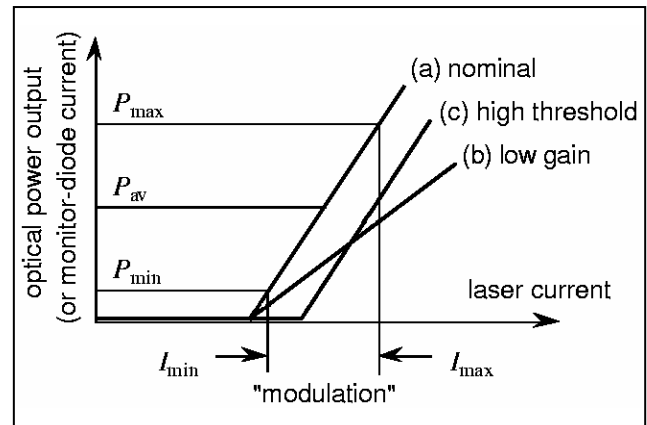

Figure 1. Characteristics of a typical dc-coupled communications laser diode. The horizontal axis represents current flowing into the laser, and the vertical axis represents optical output power (or equivalently, monitor-diode current since this is proportional to optical output power).

For example, suppose we have set up a laser driver with appropriate values of  $I_{max}$  and  $I_{min}$  to achieve desired values for  $P_{av}$  and  $r_e$ , using the nominal laser characteristic (a) in Figure 1. Now suppose the actual laser characteristic is different from nominal. We will consider two cases:

Case 1. The laser slope efficiency is reduced, but the threshold is unchanged (this could be the result of initial manufacturing tolerances, or of a temperature change, or it could occur over a period of time as the laser ages). Referring to characteristic (b) in Figure 1, it is obvious that the maximum, minimum, and average optical power output levels are lower than the intended set-up levels, while the extinction ratio is unchanged. The system will probably remain usable, but the signal-to-noise ratio and bit error rate are degraded.

Case 2. The laser slope efficiency is unchanged but the threshold current is greater than nominal, as in Figure 1, characteristic (c). This is the disaster situation in which the laser operation falls below threshold. Other scenarios can be investigated, with various combinations of laser slope efficiency and threshold, but it is obvious that, for specified average optical power output, the disaster situation becomes more likely as the nominal extinction ratio is made larger.

## 2 Optical Feedback via a Monitor Diode

Many laser assemblies include a monitor photo diode. Photo diodes are essentially linear in their relation between optical power input and reverse-biased current. Incident photons generate hole-electron pairs in the diode, and increase its reverse leakage current above the “dark” value. Thus, monitor current is a measure of laser optical power output and, by incorporating the laser and monitor into a suitable feedback system, it should be possible to control the optical output. Figure 2 shows the general idea.

The desired laser optical output waveform is first scaled by a factor that is the inverse of monitor gain,  $A_{\text{monitor}}$ , where

$$A_{\text{monitor}} = \frac{d(\text{monitor photocurrent})}{d(\text{laser optical power output})}. \quad (4)$$

This scaled waveform is used as input to a “classical” feedback control system, in which the forward path consists of a high-gain current amplifier plus the laser acting in cascade, and the monitor diode constitutes the feedback network.

Then, provided only that the loop gain is large at all frequencies of concern, the actual optical output waveform from the laser mimics the desired waveform:

$$\text{loop gain} = A_{\text{amplifier}} \times A_{\text{laser}} \times A_{\text{monitor}}. \quad (5)$$

$P_{\text{max}}$  and  $P_{\text{min}}$ , hence  $P_{\text{av}}$  and  $r_e$ , are all controlled and held constant despite variations in the laser characteristic.

The trouble is that photo diodes have a limited bandwidth; details vary, but typical diodes behave much like a low-pass filter with a cutoff around 100MHz. Diodes can of course be manufactured with larger bandwidths, but at increased cost and with other problems. When the data rate is low (perhaps up to 100Mbps), the system can be made to work. However a number of things go wrong at high data rates:

- Basically, the problems all stem from the fact that the loop bandwidth must be of the same order as the bit rate, for satisfactory reproduction of the input waveform. Thus a 2.5Gbps data waveform requires a bandwidth around 2.5GHz. (2GHz or even 1.5GHz might be enough, depending on the fidelity requirement, but the order of magnitude is 2.5GHz.)
- The monitor diode contributes a dominant pole at about 100MHz to the feedback loop. Therefore the requirements on the high-gain current amplifier become extreme: it is difficult to stabilize the feedback loop.

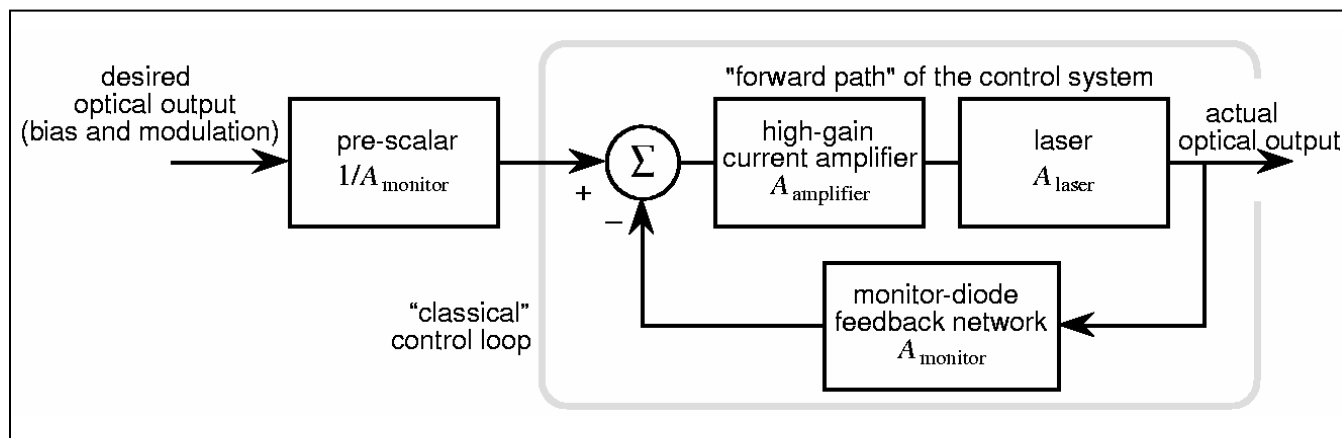

Figure 2. Feedback control of a laser

- Recall that the overall response of a feedback system has a zero at each pole of its feedback network. Therefore, the overall gain of the feedback part of Figure 2 rises above 100MHz, and its output becomes extremely noisy. Another way of looking at it is that the feedback becomes ineffectual above 100MHz, so the system output includes all the noise of the high-gain amplifier running without feedback.

## 2.1 Automatic Power Control

Something useful can be achieved by abandoning the quest for large loop bandwidth, and replacing the high-gain amplifier by an integrator:

$$A_{\text{amplifier}} \Rightarrow \frac{1}{s\tau} \quad (6)$$

When

$$\frac{\text{actual optical output}}{\text{desired optical output}} = \frac{1}{1 + s\tau A_{\text{laser}} A_{\text{monitor}}}, \quad (7)$$

the system becomes a low-pass filter. If the integrator time constant  $\tau$  is chosen long enough, the average optical power output  $P_{\text{av}}$  becomes equal to the desired average output, independent of the detail of the data pattern in the modulation waveform. However, all the high-frequency information in the modulation waveform is filtered out, so  $P_{\text{max}}$ ,  $P_{\text{min}}$ ,

and the difference between them are not controlled. Automatic power control (APC) is achieved, but not automatic modulation control (AMC).

Laser driver systems incorporating APC are quite common. The user can program the average optical power output, and this will be maintained automatically despite variations in the laser. However, peak-peak optical output and extinction ratio are not controlled, and must be set up and tweaked for each individual laser.

## 3 Automatic Modulation Control via a Pilot Tone

Maxim's MAX3865, achieves automatic modulation control by adding a small pilot tone to the laser current. This pilot tone is a square wave with a frequency of about 1MHz (low enough that it can pass through the monitor diode without attenuation). Figure 3 shows a simplified block diagram. The control loops for laser bias (average) current and modulation (peak-peak) current are separated.

The automatic power control (APC) feedback loop holds the bias or average current in the monitor diode constant, and is basically the same as Figure 2. The desired (pre-scaled) bias current enters at the center-left in Figure 3. (The pre-scalar is omitted

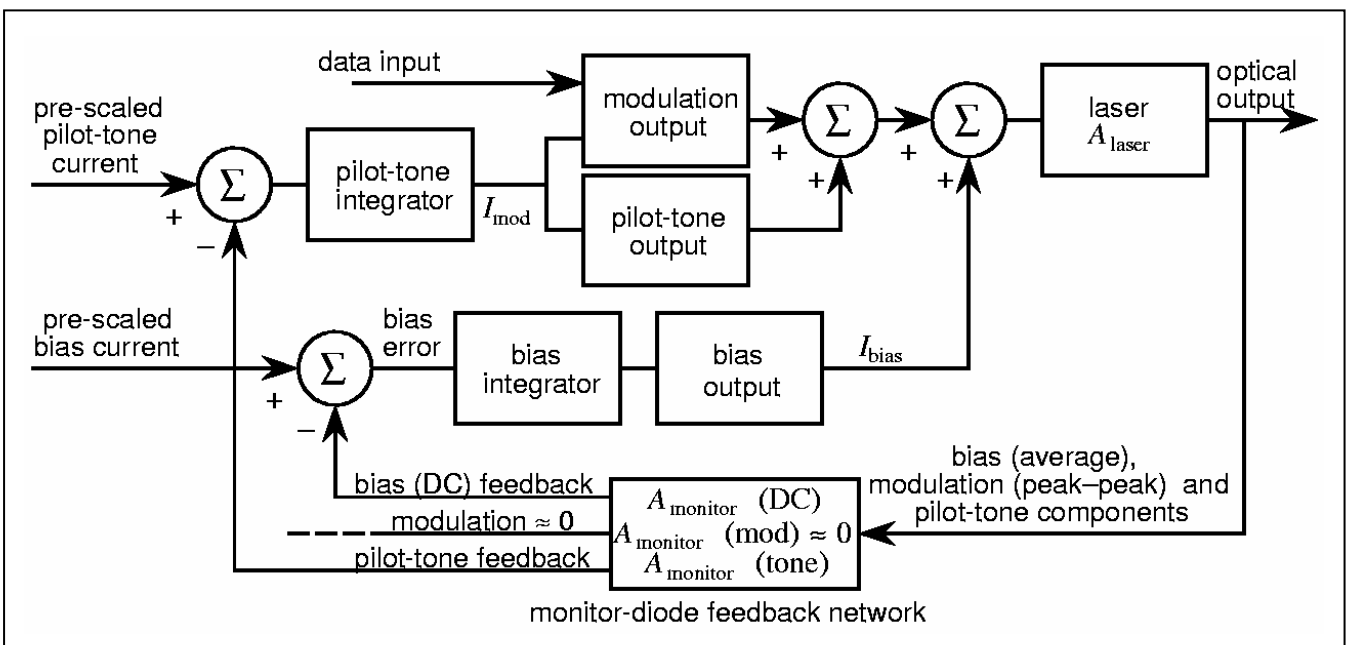

Figure 3. Conceptual block diagram of a laser driver with APC and AMC

from Figure 3 for simplicity.) The DC current (or bias) in the monitor diode is subtracted from the entering pre-scaled bias current. The resulting difference or *bias error* is integrated, and applied to the laser via a suitable high-current output stage. In the steady state, the bias error must be zero, or else the integrator output would be changing, which denies the steady state. Therefore the bias feedback must be equal to the pre-scaled bias current input. Average monitor-diode current is controlled, hence average optical power output from the laser is controlled.

To understand the operation of the automatic modulation control (AMC) function, suppose initially that the modulation current  $I_{mod}$  (located near the center of Figure 3) is known. Then the peak-peak data or modulation current in the laser is known, and the pilot-tone current is known. At the

output of the monitor diode, the modulation component of current is near zero because of the restricted bandwidth, but the pilot-tone component is not similarly restricted and is a true indication of the pilot-tone component of optical output. The desired pilot-tone current enters Figure 3 at the top-left (again, the pre-scalar of Figure 2 is omitted for simplicity), and from this current, the pilot-tone feedback current is subtracted. The resulting difference or *pilot-tone error* is integrated and becomes  $I_{mod}$ . As with the bias control loop, in the steady state, the pilot-tone feedback current must be equal to the pilot-tone input.

## 4 Detailed Description

Figure 4 is a block diagram of the MAX3865, simplified only in that the current-scaling factors

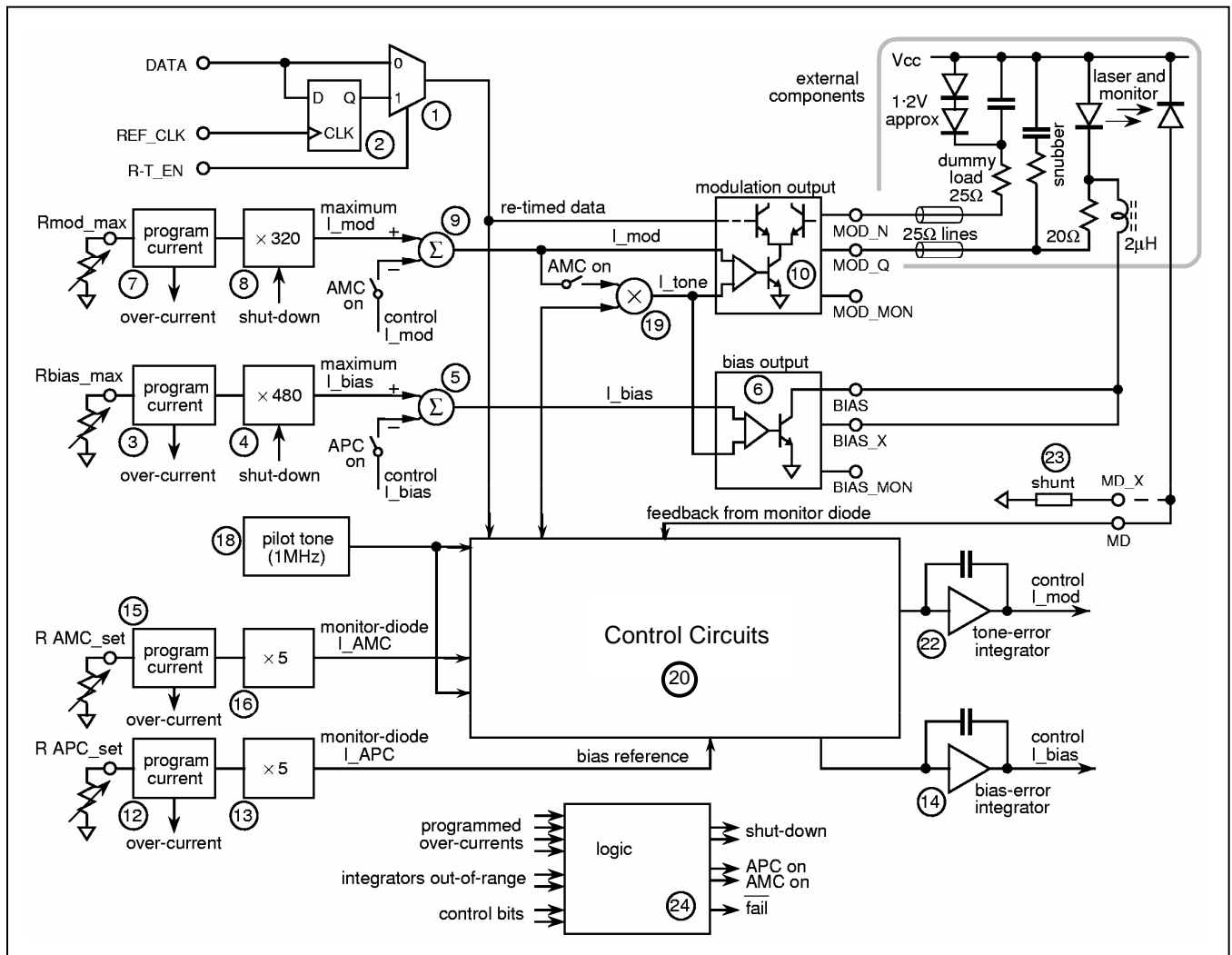

Figure 4. Block diagram of the MAX3865 laser driver, which includes both APC and AMC

which are shown localized as blocks #4, #8, #13 and #16 are in fact distributed throughout the chip. The maximum current in any external programming resistor is about 200µA. The currents in blocks such as the adders, multipliers and integrators are a few microampères, appropriate for realization in integrated-circuit form. Only in the circuit blocks which interface with the outside world are the currents significantly large.

- maximum bias current output to laser = 100mA
- maximum modulation current output to laser = 60mA peak-peak
- maximum instantaneous current in monitor diode = 1mA

Monitor pins BIAS\_MON and MOD\_MON provide access to the actual bias and modulation currents, with scale factors of 1/48 and 1/32 respectively.

The circuit has four modes of operation, which are programmed by two TTL-compatible control bits:

- (0,0) = shut down,
- (0,1) = manual mode,
- (1,0) = APC mode,
- (1,1) = AMC mode.

In the shut-down mode, all laser currents are forced to zero, but the rest of the circuit remains operative; in particular, the various integrators are primed and ready to go, once a working mode is selected. A TTL-compatible active-low warning flag, FAIL, is set under fault conditions.

In all modes, the input data can be routed directly to the modulation output stage #10 via multiplexer #1, or it can be routed via the re-timing latch #2. In the latter case, jitter present on the data can be eliminated if a reference clock is available. Re-timing is enabled via a TTL-compatible active-high control pin R-T\_EN.

## 4.1 The Manual Mode

In the manual mode, the laser bias and modulation currents are programmed directly via external resistors or small current-output DACs. As noted, the maximum current that flows in any programming resistor is about 200µA.

Bias output current is programmed in #3 by connecting a resistor to ground:

$$I_{\text{bias}} = 480 \left[ \frac{1.2\text{V}}{R_{\text{bias\_max}} + 2\text{k}\Omega} \right] \quad (8)$$

$$= 480 \times I(R_{\text{bias\_max}}).$$

where  $I(R_{\text{bias\_max}})$  is the current flowing through  $R_{\text{bias\_max}}$ . The rationale for the terminology  $R_{\text{bias\_max}}$  is explained in Section 4.2. Block #3 is protected against short-circuits to ground or  $V_{\text{CC}}$  at the programming pin and the whole chip shuts down if the current is programmed too large. From #3, the bias current flows via subtractor #5 (note that its second input is off in this operating mode) to the bias output amplifier #6. It then flows to the laser cathode via a small inductor, which isolates the laser from the output capacitance of the amplifier.

Similarly, peak-peak or modulation output current is programmed in #7 by connecting a resistor to ground:

$$I_{\text{mod}} = 320 \left[ \frac{1.2\text{V}}{R_{\text{mod\_max}} + 2\text{k}\Omega} \right] \quad (9)$$

$$= 320 \times I(R_{\text{mod\_max}}).$$

where  $I(R_{\text{mod\_max}})$  is the current flowing through  $R_{\text{mod\_max}}$ . From #7, the current flows via subtractor #9 (its second input is off) to the modulation output stage #10, and thence to the laser. In essence, the modulation output stage consists of a differential pair, with its bases driven by the data waveform and with a DC tail current equal to the programmed peak-peak modulation current.

With the arrangement in Figure 4, the correspondences between the chip current outputs  $I_{\text{bias}}$  and  $I_{\text{mod}}$  and the laser currents  $I_{\text{max}}$  and  $I_{\text{min}}$  in Figure 1 are:

$$\text{laser } I_{\text{min}} = \text{chip } I_{\text{bias}}, \quad (10)$$

$$\text{laser } I_{\text{max}} = \text{chip } I_{\text{bias}} + \text{chip } I_{\text{mod}}. \quad (11)$$

### 4.1.1 Layout: Parasitic C and L

Voltage and current changes in the modulation output stage and laser are extremely fast—up to about  $10^{10}\text{V/sec}$  and  $10^9\text{A/sec}$ . Therefore, substantial currents flow to ground in even minute stray capacitances, and substantial voltage drops occur across minute lead inductances. These can degrade the data waveforms.

$$I = C \frac{dV}{dt}, \quad (12)$$

$$V = L \frac{dI}{dt}. \quad (13)$$

Every effort should therefore be made to minimize parasitic  $C$  and  $L$ . Good physical layout is essential. As shown in Figure 4, the two sides of the modulation-output differential pair (the so-called DUMMY and LASER outputs of the chip) are loaded equally. The output currents are routed via equal-length  $25\Omega$  strip lines to the  $25\Omega$  dummy load and laser. The laser impedance is built out to  $25\Omega$  by a series resistor (approximately  $20\Omega$ ), and an  $RC$  snubber at least partially compensates for laser inductance. The  $25\Omega$  dummy load, the laser and snubber all return to the same  $V_{CC}$  supply point.

#### 4.1.2 AC-Coupling and DC-Coupling

The collectors of the modulation-output transistors must remain above  $1.8V$ , in order to provide headroom for these collectors and the tail transistor which sits underneath them. In Figure 5,

$$V_{\text{modulation out}} = V_{CC} - V_{\text{laser}} - V_{\text{series R}} - V_{\text{parasitic L}}. \quad (14)$$

Typical lasers drop more than a volt and, at the modulation current peaks, the series resistor drops another volt. It is extremely difficult to achieve parasitic inductance less than  $1nH$ —this corresponds to about  $1mm$  of PCB trace unless that trace is a properly terminated transmission line. In accordance with Equation 13, the peak drop across this inductance is yet another volt. Substitution of all these values into Equation 14 shows that the  $V_{CC}$  supply needs to be around  $5V$ ; the industry standard of  $3.3V$  is simply not enough.

However the MAX3865 provides for  $3.3V$  operation by AC-coupling the modulation outputs to the laser. In Figure 5, the mean voltage at the modulation outputs is  $+V_{CC}$  (the average voltage across an inductor must be zero). The actual output voltage swings about this mean, rising above  $V_{CC}$  when the instantaneous modulation current is small, and falling below it when the current is large. Referring to the laser currents in Figure 1:

$$\text{laser } I_{\min} = \text{chip } I_{\text{bias}} - \frac{1}{2} \text{chip } I_{\text{mod}}, \quad (15)$$

$$\text{laser } I_{\max} = \text{chip } I_{\text{bias}} + \frac{1}{2} \text{chip } I_{\text{mod}}. \quad (16)$$

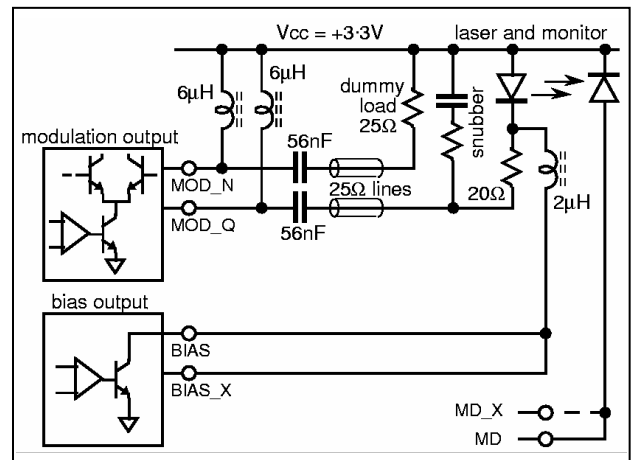

Figure 5. AC coupling of the MAX3865 to a laser for operation with  $V_{CC} = 3.3V$ . The combination of  $6\mu H$  and  $56nF$  gives critical damping with  $25\Omega$  and a coupling time constant of  $600nsec$ , equivalent to  $1500$  bits at  $2.5 Gbps$ . Both  $L$  and  $C$  should be increased proportionately if a longer time constant is required.

#### 4.2 The APC Mode

In the APC mode, the second input to subtractor #5 is enabled. What goes to the bias output stage is not the current as programmed in #3 and #4, but the difference between this and the output from the bias integrator #14. The current  $I_{\text{bias}}$  subtracts from the programmed  $I_{\text{bias}}$  to give the actual  $I_{\text{bias}}$  in the laser, and this cannot exceed the programmed current. Thus, the terminology  $R_{\text{bias\_max}}$  is appropriate for this mode of operation. The arrangement provides an automatic safety feature against overdriving and destroying the laser under fault conditions.

When the APC loop has settled to equilibrium, the average or DC component of the feedback current from the monitor diode, going into #20, must be equal to the sum of the average components of the other three currents. If, for example, the monitor-diode feedback current is momentarily too large, the output of integrator #14 moves positive and, at #5, this reduces the bias current to the laser. But the averages of the tone reference and mark-density compensation currents must be zero because these originate in multipliers. (See Section 4.2.1 below.) Therefore, the average current in the monitor diode must equal the programmed bias reference current, which originates in #12:

$$I_{\text{av}(\text{monitor diode})} = 5 \left[ \frac{1.2\text{V}}{R_{\text{APC\_set}} + 2\text{k}\Omega} \right] \quad (17)$$

$$= 5 \times I(R_{\text{APC\_set}}).$$

where  $I(R_{\text{APC\_set}})$  is the current flowing through  $R_{\text{APC\_set}}$ . Average optical power output from the laser is controlled.

The stability of the APC feedback loop depends on a combination of the bias-integrator time constant and the other gains and poles around the loop. In particular, it depends on the laser-to-monitor current gain. Current shunt #23 is provided to reduce the loop gain when the laser-to-monitor current gain is too large. For laser gains less than 0.005, either connect MD\_X to ground or leave it unconnected; for laser gains greater than 0.02, connect MD\_X to MD; for laser gains between 0.005 and 0.02, use either arrangement.

#### 4.2.1 Mark-Density Compensation

In the very long term, the data input contains equal numbers of 0s and 1s, and the average optical power output is truly the average of the powers that correspond to data\_0 and data\_1. However, in the shorter term there may be a local excess of either 0s or 1s. Said differently, the very-long-term mark density is 50%, but the short-term mark density is not 50%.

Any APC loop attempts to hold the average power constant, and therefore adjusts the powers that correspond to data\_0 and data\_1, up or down depending on the local mark density. The rate at which this adjustment takes place is set by the APC loop time constant. One common approach to reducing this undesirable effect is to make the APC time constant very long, but this has the disadvantage of slowing the response to other changes. The MAX3865 uses a different technique, mark-density compensation.

When the local mark-density of the data is 50%, the average output from the mark-density multiplier is zero. However, when the data consists locally of an excess of 1s, the average output from the mark-density multiplier goes positive and adds to the bias reference current. The numerical details in Figure 4 are such that this increase in effective reference current compensates exactly for the local increase in feedback current from the monitor diode, provided the current, *monitor-diode*  $I_{\text{AMC}}$ , which originates in #15, is programmed equal to the difference between

the data\_0 and data\_1 currents in the monitor diode. (This requires *monitor-diode*  $I_{\text{AMC}}$  to be programmed equal to the monitor-diode modulation current.) There is then no error output applied to the input to integrator #14, and no shift in the laser bias current.

### 4.3 AMC Mode

In the AMC mode, the second input to subtractor #9 is enabled, also the second input to multiplier #19. The current *maximum*  $I_{\text{mod}}$  programmed in #7 takes on the significance of an upper bound to the peak-peak modulation current output—exactly like the arrangement for bias current described in Section 4.2. Current *control*  $I_{\text{mod}}$  subtracts away from maximum  $I_{\text{mod}}$  to give the actual  $I_{\text{mod}}$  in the laser.

Multiplier #19 generates a pilot-tone current and adds this to both the bias and modulation output currents. There is, therefore, a pilot-tone component of current in the monitor diode.

When the AMC loop has settled to equilibrium, the pilot-tone component of feedback current from the monitor diode must be equal to the pilot-tone reference current that originates in #15, #16 and #20. If, for example the monitor-diode feedback current is momentarily too large, the resulting difference reduces the modulation current (and hence pilot-tone current) in the laser. The pilot-tone current in the monitor diode, and hence peak-peak modulation current, is controlled:

$$I_{\text{p-p}(\text{monitor diode})} = 5 \left[ \frac{1.2\text{V}}{R_{\text{AMC\_set}} + 2\text{k}\Omega} \right] \quad (18)$$

$$= 5 \times I(R_{\text{AMC\_set}}).$$

where  $I(R_{\text{AMC\_set}})$  is the current flowing through  $R_{\text{AMC\_set}}$ . Peak-peak optical power output from the laser is controlled.

In summary, the average optical power output and extinction ration in the AMC mode are given by:

$$P_{\text{av}} = \frac{I_{\text{av}(\text{monitor diode})}}{A_{\text{monitor}}}$$

$$= \frac{6\text{V}}{(R_{\text{APC\_set}} + 2\text{k}\Omega) A_{\text{monitor}}}$$

$$= \frac{5 \times I(R_{\text{APC\_set}})}{A_{\text{monitor}}}, \quad (19)$$

and

$$\begin{aligned}
r_e &= \frac{I_{av(\text{monitor diode})} + \frac{1}{2}I_{P-P(\text{monitor diode})}}{I_{av(\text{monitor diode})} - \frac{1}{2}I_{P-P(\text{monitor diode})}} \\
&= \frac{R_{AMC-set} + \frac{1}{2}R_{APC-set} + 3k\Omega}{R_{AMC-set} - \frac{1}{2}R_{APC-set} + 1k\Omega} \\
&= \frac{I(R_{APC-set}) + \frac{1}{2}I(R_{AMC-set})}{I(R_{APC-set}) - \frac{1}{2}I(R_{AMC-set})}, \quad (20)
\end{aligned}$$

where  $A_{\text{monitor}}$  is the monitor-diode gain as defined in Equation 4.

The MAX3865 can be DC-coupled to the laser for operation at  $V_{CC} = 5V$ , or AC-coupled for  $V_{CC} = 3.3V$ . Programming resistors  $R_{APC-set}$  and  $R_{AMC-set}$  are not affected, mark-density compensation is automatic in either case.

#### 4.3.1 Laser End-of-Life

As a laser nears the end of its useful life, the bias and modulation currents required to maintain its optical output become larger. The MAX3865 automatically increases its output currents, as required. The warning flag, FAIL, is set when either of the chip-output currents attempts to exceed the upper-bound values programmed by  $R_{bias\_max}$  or  $R_{mod\_max}$  (Equations #8 and #9).

Alternatively, approaching end-of-life can be detected by observing the scaled versions of  $I_{bias}$  and  $I_{mod}$  at the open-collector-output pins BIAS\_MON and MOD\_MON, and noting when these approach limit values:

$$I_{bias\_mon} = \frac{I_{bias}}{48}, \quad (21)$$

$$I_{mod\_mon} = \frac{I_{mod}}{32}. \quad (22)$$

If outputs BIAS\_MON and MOD\_MON are not used, these pins should be tied to  $V_{CC}$ .

#### 4.3.2 Feedback Via a Monitor Diode

Recognize that, for any feedback system, the overall closed-loop transfer function approaches the inverse of the transfer function of the feedback network. Therefore, if (for example) the feedback resistors around an operational amplifier change in value, the overall gain must change.

The MAX3865 is no different. In any system which uses feedback via a monitor diode to control the optical power output from a laser, the monitor diode constitutes the feedback network. Therefore, if the characteristic of the monitor changes, the optical output must change. What the MAX3865 controls and holds constant, despite changes in the laser/monitor-diode combination, are the average and peak-peak currents in the monitor diode, IAPC and IAMC.

If you change the laser characteristic by changing its temperature, you are also likely to change the monitor diode. Any observed change in the optical output from the system may be associated with the latter, not with a failure of the MAX3865 to regulate correctly.