

**Application Note:**

**HFAN-09.0.1**

Rev.2; 04/08

---

---

***NRZ Bandwidth - HF Cutoff vs. SNR***

---

---



*Maxim Integrated Products*

# NRZ Bandwidth – HF Cutoff vs. SNR

## 1 Introduction

A fundamental goal of physical layer digital communication system design is transmission of the data signal through the system with minimum distortion. In order to accomplish this goal, it is imperative to match (as closely as possible) the system bandwidth to the bandwidth requirements of the data. The purpose of this application note is to analyze the bandwidth required for effective transmission of nonreturn-to-zero (NRZ) encoded data.

## 2 NRZ Encoded Data

In order to transmit binary data, it must be encoded into a signal (e.g., an electrical or optical waveform) that is suitable for the transmission medium (e.g., copper cable, optical fiber, etc.). Of the many binary data encoding methods currently in use, nonreturn-to-zero (NRZ) is one of the most common.

In NRZ encoding, each binary digit (bit) is assigned an equal amount of time, called the bit period,  $T_b$ . During each bit period, a binary one is represented by a high amplitude, and a binary zero is represented by a low amplitude. The sequence of encoded bits is called the bit stream or data signal. Timing synchronization is maintained by a square-wave signal called the bit clock. An NRZ-encoded bit stream and the bit clock are illustrated in Figure 1.

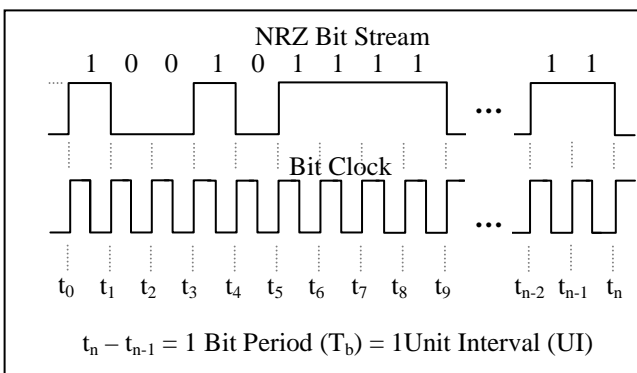

Figure 1. NRZ encoded bit stream

## 3 Autocorrelation of Random NRZ Data

The Wiener-Khinchin theorem states that, for a random process that is at least wide-sense stationary, the power spectral density of the process is equal to the Fourier transform of its autocorrelation function<sup>1</sup>. Using this theorem, we can compute the power spectral density of random NRZ data by first determining the autocorrelation function and then calculating its Fourier transform.

Random binary data can be defined as a sequence of bits in which the probability that any given bit in the sequence has a value of one or zero is independent of the value of all other bits in the sequence. In other words, we can never predict the value of the next bit in the sequence based on the previous bits (there are no patterns). We can use the random data model as the basis for determining the necessary system bandwidth.

The autocorrelation of any function of time can be computed by multiplying the function by a time-shifted version of itself and then integrating this product over all values of the time shift. This can be written mathematically as

$$R_{XX}(\tau) = \lim_{T \rightarrow \infty} \frac{1}{T} \int_{-T/2}^{T/2} X(t)X(t + \tau)dt \quad (1)$$

where  $R_{XX}(\tau)$  represents the autocorrelation of the function  $X(t)$ ,  $t$  represents time, and  $\tau$  represents the time-shift (sometimes called the *lag* or *lag factor*). Figure 2 is an example showing  $R_{XX}(T_b)$ , the autocorrelation of  $X(t)$  at a lag factor of 1 bit period, where  $X(t)$  equals the NRZ representation of the binary sequence 1011100.

To compute the autocorrelation of a random bit stream it is important to observe that there is no correlation for lag factors outside of plus or minus one bit period (i.e.,  $R_{XX}(\tau) = 0$  for  $\tau < -T_b$  or  $\tau > T_b$ ). This is due to the random nature of the bit stream, which results in the fact that, for any value of  $t$ , there is an equal probability that  $X(t)$  represents a one or a zero.

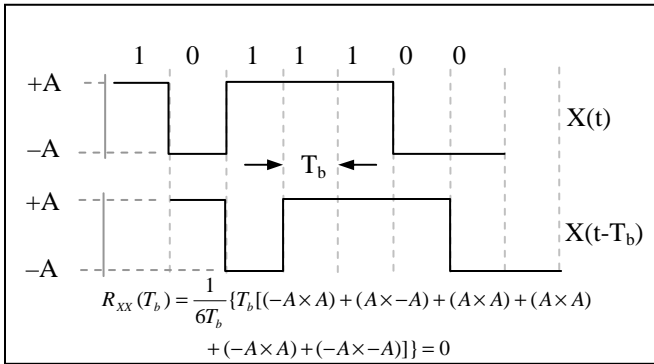

Figure 2. Autocorrelation example with  $\tau = T_b$

For example, if  $(-T_b < \tau < T_b)$  and we assume that the probability that  $[X(t) = -A]$  is 50% and the probability that  $[X(t) = +A]$  is also 50%, then there are only four equally probable possibilities for the product  $X(t)X(t-\tau)$ ; i.e.,  $(A)(A) = A^2$ ,  $(A)(-A) = -A^2$ ,  $(-A)(A) = -A^2$ , and  $(-A)(-A) = A^2$ . Since there is equal probability of  $A^2$  and  $-A^2$  at each point in the autocorrelation of a random bit stream, the sum of the products at each of the points will, in the limit, be equal to zero. The important conclusion is that, for random data, the limits on the autocorrelation integral of equation (1) can be changed to  $(-T_b$  and  $+T_b)$  since, in the limit, the autocorrelation will be zero outside of this interval.

Using the above conclusion, the autocorrelation of a random bit stream can be greatly simplified, since we only have to consider lag factors between  $-T_b$  and  $+T_b$ . In this region, the autocorrelation starts at  $R_{XX}(-T_b) = 0$ , increases linearly to a peak value  $\alpha$  at  $R_{XX}(0)$ , and then decreases linearly to a final value at  $R_{XX}(+T_b) = 0$ . The resulting triangular autocorrelation function is illustrated in Figure 3.

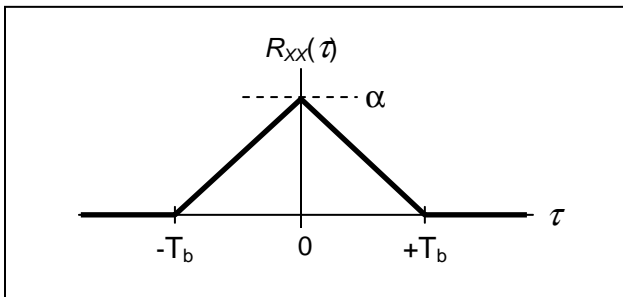

Figure 3. Autocorrelation of random NRZ data

#### 4 Power Spectrum of Random NRZ Data

The Fourier transform of a triangular function centered at zero with amplitude  $\alpha$  and width  $2T_b$  (i.e., the autocorrelation function shown in Figure 3)

Application Note HFAN-09.0.1 (Rev.2; 04/08)

is equal to  $\alpha T_b \text{sinc}^2(T_b f)$ , where  $\text{sinc}(f)$  is defined as  $(\sin \pi f)/\pi f$  and  $f$  is the frequency in Hertz<sup>2</sup>. This result is the power spectral density of the random NRZ bit stream and is illustrated in Figure 4 (note that the frequency axis is normalized to the data rate).

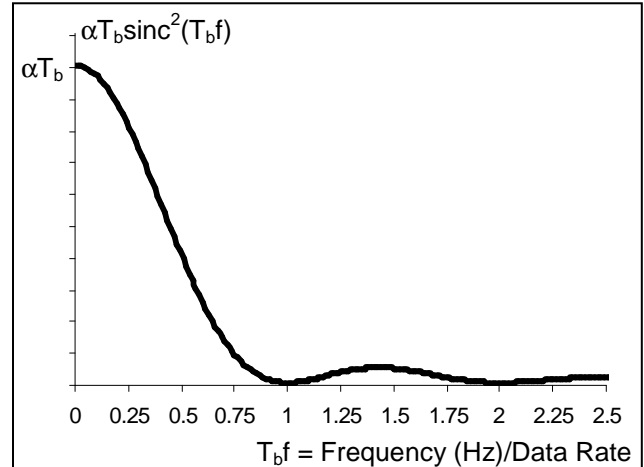

Figure 4. Power spectrum of random NRZ data

#### 5 Bandwidth Limits

The power spectrum of random NRZ data includes non-zero components that extend out to infinite frequencies. Since real systems have high frequency cutoffs that limit the bandwidth to finite values, an important question is: Where should these cutoffs be placed?

Since the fundamental frequency of the fastest bit transitions in an NRZ bit stream (i.e., a repeating one-zero pattern) is one-half of the data rate, this represents the lowest possible high-frequency cutoff. More bandwidth is required, however, to reduce distortion of the data signal and increase the signal-to-noise ratio.

Integration of the power spectrum of Figure 4 over the full frequency range provides considerable insight into possible choices for the high-frequency cutoff, as shown in Figure 5. This figure shows that the majority of the power (94% of the total) in random NRZ data is contained in the spectrum between the frequencies of 0 and 0.75 times the data rate. Tabulated values for the cumulative power of Figure 5 are shown in Table 1. As Figure 5 and Table 1 illustrate, the gain in signal power with increased bandwidth almost levels off somewhere between 0.75 and 0.8 times the data rate and then

increases somewhat between 1.2 and 1.6 times the data rate. It is important to note that, if the bandwidth is doubled from 0.75 to 1.5 times the data rate, then the total cumulative power increases from 93.6% to 98.1% for a net power gain of only 4.5%. Another way to state this is that a 100% increase in bandwidth (from 0.75 to 1.5 times the data rate) only provides a 4.5% increase in signal power.

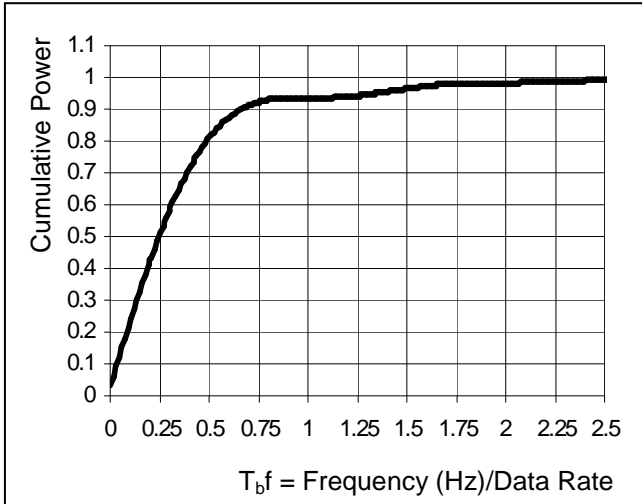

Figure 5. Cumulative (integrated) power spectrum of random NRZ data

**Table 1. Tabulated Values for Cumulative Power in Random NRZ**

Frequency(Hz) Data Rate(bits/s)	Cumulative % of Total Power
0.5	81.4%
0.75	93.6%
0.8	94.3%
0.9	95.0%
1.0	95.1%
1.1	95.2%
1.2	95.5%
1.3	96.2%
1.4	97.1%
1.5	98.1%
1.6	98.9%
1.7	99.5%
1.8	99.9%

When choosing the high-frequency cutoff, it is important to consider the effect of increased bandwidth on the system noise. The power spectrum of random Gaussian noise can be modeled as a constant (horizontal line) over the entire frequency spectrum<sup>3</sup>. This means that the cumulative noise power increases linearly as the bandwidth increases, and therefore the system signal-to-noise ratio (SNR) will also change with the bandwidth. As noted previously, increasing the high-frequency cutoff above 0.75 results in only a small increase in signal power. But, since the cumulative noise power increases linearly over the entire spectrum, this increase in high-frequency cutoff will result in a significant gain in noise power.

For example, let us assume that the SNR at a normalized bandwidth of 0.75 is equal to 12.7, which equates to a bit error ratio (BER) of  $10^{-10}$ , when considering only the effects of Gaussian noise. (For more detail on the relationship between SNR and BER see Maxim application note [HFAN-4.0.2 "Converting Between RMS and Peak-to-Peak Jitter at a Specified BER."](#)) If the normalized bandwidth is increased by 33% (to 1.0), the noise power will also increase by 33%. Meanwhile, the signal power will increase by only 1.5%. The result is a change in system SNR that can be calculated as

$$\frac{S(f_c = 1.0)}{N(f_c = 1.0)} = \frac{1.015 \times S(f_c = .75)}{1.333 \times S(f_c = .75)} \quad (2)$$

$$= 0.76 \times 12.7 = 9.65$$

where  $S$  is the signal power,  $N$  is the noise power, and  $f_c$  is the high-frequency cutoff. For an SNR of 9.65, the corresponding BER is  $6.84 \times 10^{-7}$ . Thus a 33% increase in bandwidth resulted in a reduction of BER by a factor of 6,840!

## 6 Conclusions

For systems transmitting random NRZ data, the majority of the signal power (94%) is contained within the frequency spectrum between 0 and 0.75 times the data rate. Noise power, on the other hand, accumulates at a constant rate as the high-frequency

cutoff is increased. The result is a rapid decrease in signal-to-noise ratio when the high-frequency cutoff is increased beyond 0.75, which leads to a significant degradation in bit error performance. Thus, for most systems transmitting random NRZ data, 0.75 times the data rate is a good choice for the high-frequency cutoff.

---

<sup>1</sup> J.W. Goodman, *Statistical Optics*, New York, NY: John Wiley & Sons 1985, p. 74.

<sup>2</sup> J.D. Gaskill, *Linear Systems, Fourier Transforms, and Optics*, New York, NY: John Wiley & Sons 1978, p. 201.

<sup>3</sup> H. Taub and D. Schilling, *Principles of Communication Systems, 2<sup>nd</sup> Edition*, New York, NY: McGraw-Hill, 1986, p.328.