



APPLICATION NOTE 844

## Low-Cost Anemometer Fights Dust

*Abstract: This application note describes a low-cost circuit that can detect when a chassis fan filter has become clogged with dust. It does this by using a temperature sensor to determine the rate of cooling of a transistor in the air path of the cooling fan, thereby implementing a simple thermal anemometer.*

As higher levels of power dissipation underscore the need for cooling (especially for processors), more and more fans are finding their way into small electronic enclosures. The dust pulled into these enclosures by fans, however, can cause major problems for high reliability systems. By coating heat sinks and electrically charged components, it acts as a blanket that raises the effective thermal impedance between those components and the air.

A simple way to combat this problem is to place a disposable filter on the air intake. If the user fails to replace the filter on a regular basis, however, it can become clogged and act as an air dam. That condition is worse than the original problem. Trying to sense a clogged filter by sensing the fan rotation with tachometer signals is useless, because fan rotation is not directly related to airflow.

Poor filter maintenance can be detected by determining the actual airflow with a "hot wire" anemometer, but most electronic anemometers are costly and bulky. As an alternative, an SMBus $\Omega$ /I<sup>2</sup>C anemometer can be created using an I/O expander, a few inexpensive switches, and a low-cost remote-temperature sensor (**Figure 1**). This sensor employs the base-to-emitter voltage of a transistor (Q3) to determine the transistor's junction temperature. Airflow is determined as follows:

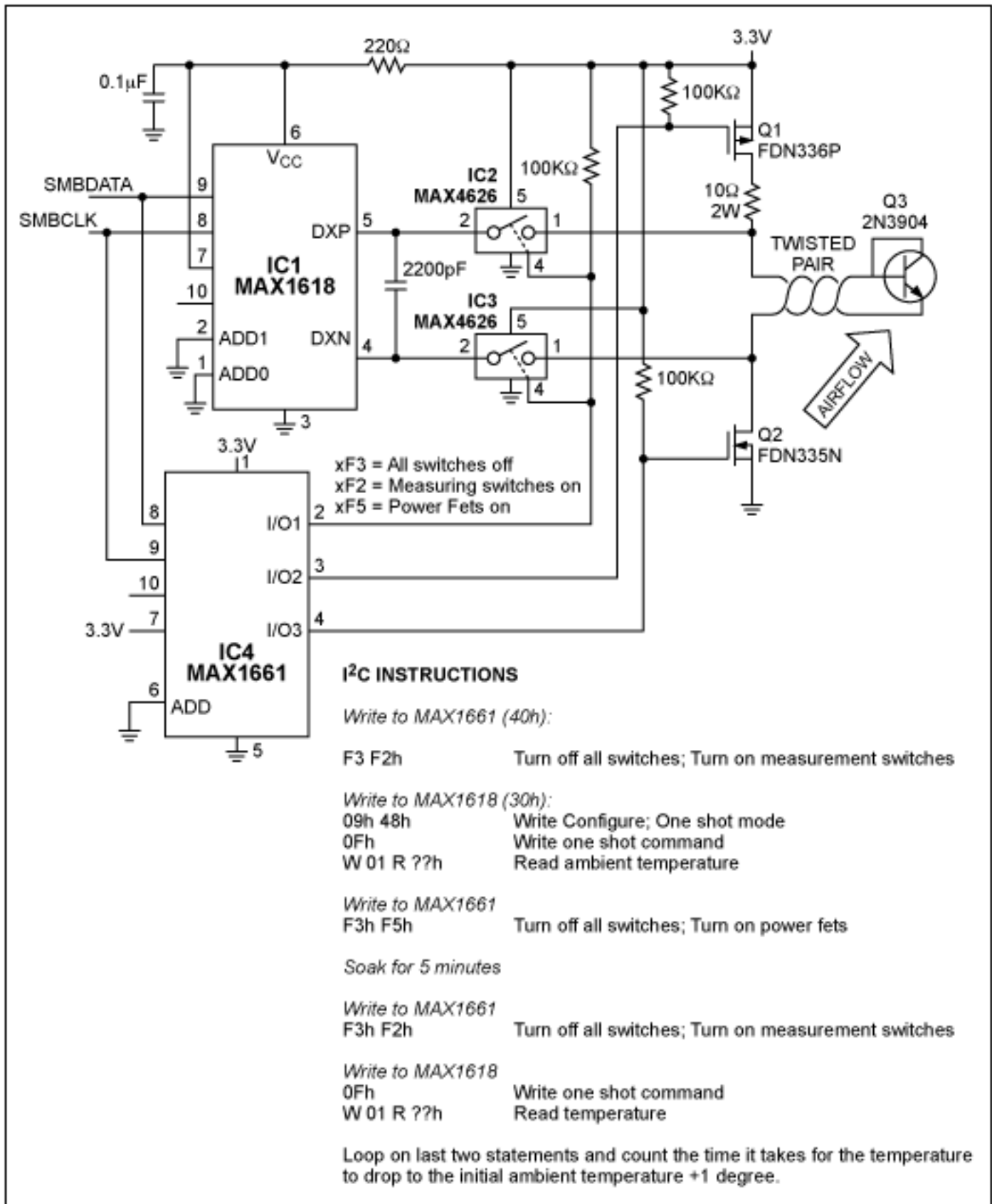

Figure 1. By heating a temperature-sense element (Q3) and then noting the time for it to return within 1°C of its original temperature, this anemometer measures the rate of airflow.

Using SMBus I/O expander IC4, turn off MOSFETs Q1 and Q2, and turn on the analog switches IC2 and IC3. Measure the ambient-air temperature with no preheating on Q3. Then, to apply current for heating Q3, turn off IC2 and IC3, and turn on Q1 and Q2. Allow an approximate five-minute "soak" to reach temperature equilibrium. (The exact heating time necessary for equilibrium depends on the setup, and must be determined by

experiment.)

When equilibrium is attained, remove power from Q3 by turning off Q1 and Q2, and turn on the analog switches IC2 and IC3 to make temperature measurements. Airflow is directly related to the rate at which the temperature drops, and can be determined by noting the time required for the transistor to return to within 1°C of its original temperature.

The temperature sensor injects a very small current into the base junction, so layout is important to keep noise off the DXP and DXN lines. If the remote transistor is to be mounted in an air channel, the use of a twisted-wire connection will allow distances up to 12 feet. The following table lists airflow vs. cooling time for a sensor placed about 12 inches away from a fan running at full speed (12V), at medium speed (8V), at low speed (6V) and zero speed (off).

Fan Voltage	Cooling Time
12V	30 sec
8V	47 sec
6V	60 sec
No Fan	84 sec

Longer power-soak times, (up to 30 minutes), do not alter these values significantly.

The circuit draws about 200mA when Q3 is heating. If this power dissipation is a problem, one can lower the frequency of measurement to hourly or even daily cycles, because changes in airflow occur slowly over time. Measurements can also be scheduled during times of low system activity, when the overall power use is down.

A similar version of this article appeared in the August 30, 2001 issue of *EDN* magazine.

SMBus is a trademark of Intel Corp.

---

Application Note 844: <http://www.maxim-ic.com/an844>

### More Information

For technical questions and support: <http://www.maxim-ic.com/support>

For samples: <http://www.maxim-ic.com/samples>

Other questions and comments: <http://www.maxim-ic.com/contact>

### Related Parts

MAX1618: [QuickView](#) -- [Full \(PDF\) Data Sheet](#)

MAX1661: [QuickView](#) -- [Full \(PDF\) Data Sheet](#)

MAX4626: [QuickView](#) -- [Full \(PDF\) Data Sheet](#) -- [Free Samples](#)

AN844, AN 844, APP844, Appnote844, Appnote 844

Copyright © by Maxim Integrated Products

Additional legal notices: <http://www.maxim-ic.com/legal>