



APPLICATION NOTE 823

Two ICs Convert 4-20mA Signal to 0-5V Output

Abstract: This design idea describes a simple circuit that converts a 4-20mA signal to a 0V to 5V analog voltage ideal for conversion to digital with an analog-to-digital converter (ADC). The 4mA level from the transducer produces a 0V output and the 20mA level produces a 5V output. A current sense amplifier generates this analog 0V to 5V output. In addition, the circuit provides a comparator output that can be used to detect a zero current condition.

In standard process-monitoring equipment, the outputs of 4-20mA transducers must be converted to signal voltages suitable for measurement by an A/D converter. Four milliamps in the loop is usually calibrated as zero for the quantity being monitored, and should therefore produce 0V at the ADC input. (Non-zero current enables the system to distinguish a broken loop from the zero-signal condition.)

The circuit in **Figure 1** monitors loop current with a current-sense amplifier (IC1), and employs a comparator/reference/op-amp device (IC2) to generate a ground-referenced output that ranges from 0V at 4mA to 5V at the full-scale loop current (20mA). For the resistor values shown (R2-R6), IC1 produces an output at pin 8 of approximately 1.25V at 4mA, and 6.25V at 20mA. In turn, the IC2 op amp (configured as a unity-gain difference amplifier) generates an output range of 0.05V to 5.045V. The IC2 comparator can be used to monitor input voltage or flag a pre-set loop current.

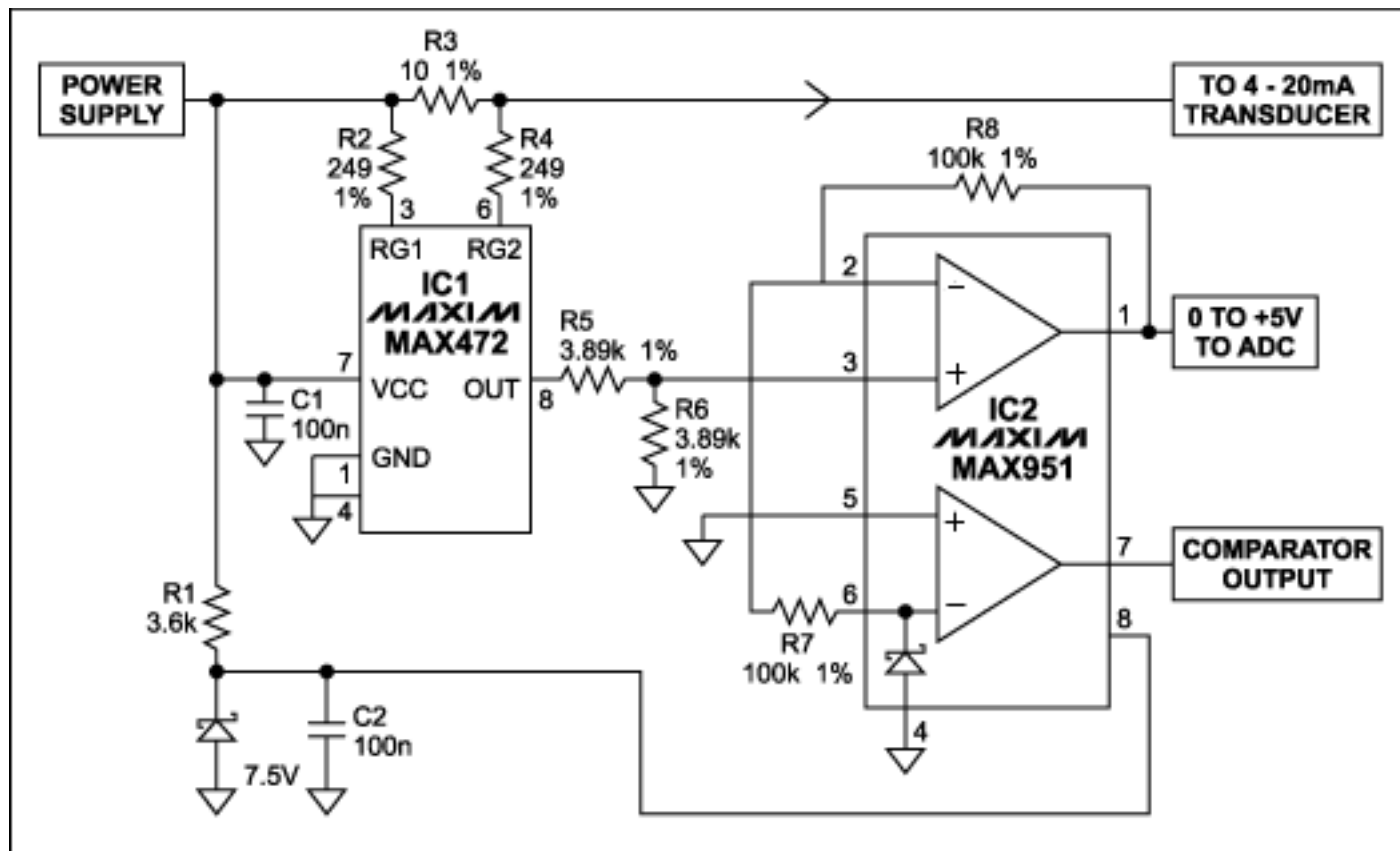

Figure 1. This circuit derives a 0V-5V output from a 4-20mA current-loop signal, using a load resistor of only 10Ω .

The circuit performs well with 1% resistors. Monte Carlo analysis indicates a worst-case output error of 5% due to resistance mismatch alone, but the performance with unmatched components was better than 1% at full-scale. By compensating for the dominant error (about +50mV of offset error at zero and full-scale), the circuit demonstrated an accuracy of better than 1% across the operating range (i.e., from 4mA to 20mA).

Application Note 823: <http://www.maxim-ic.com/an823>

More Information

For technical questions and support: <http://www.maxim-ic.com/support>

For samples: <http://www.maxim-ic.com/samples>

Other questions and comments: <http://www.maxim-ic.com/contact>

Related Parts

MAX472: [QuickView](#) -- [Full \(PDF\) Data Sheet](#)

MAX951: [QuickView](#) -- [Full \(PDF\) Data Sheet](#) -- [Free Samples](#)

AN823, AN 823, APP823, Appnote823, Appnote 823

Copyright © by Maxim Integrated Products

Additional legal notices: <http://www.maxim-ic.com/legal>