

APPLICATION NOTE 806

RF ICs for 3.5GHz WLL Transceivers

Abstract: This article provides a block diagram of the RF ICs available at 3.5GHz for wireless local loop (WLL) transceivers. The MAX2645 Silicon Germanium low-noise amplifier (LNA) provides a 25dB gain step from digital logic. The MAX2684 will upconvert from 1GHz and downconvert to a 1GHz IF. The MAX2620 is a voltage-controlled oscillator (VCO) with two buffered outputs. VCO buffer amplifiers, MAX2472 and MAX2473 maintain high isolation and keep harmonics -25dBc.

Additional Information:

- [Wireless Product Line Page](#)
- [Applications Technical Support](#)

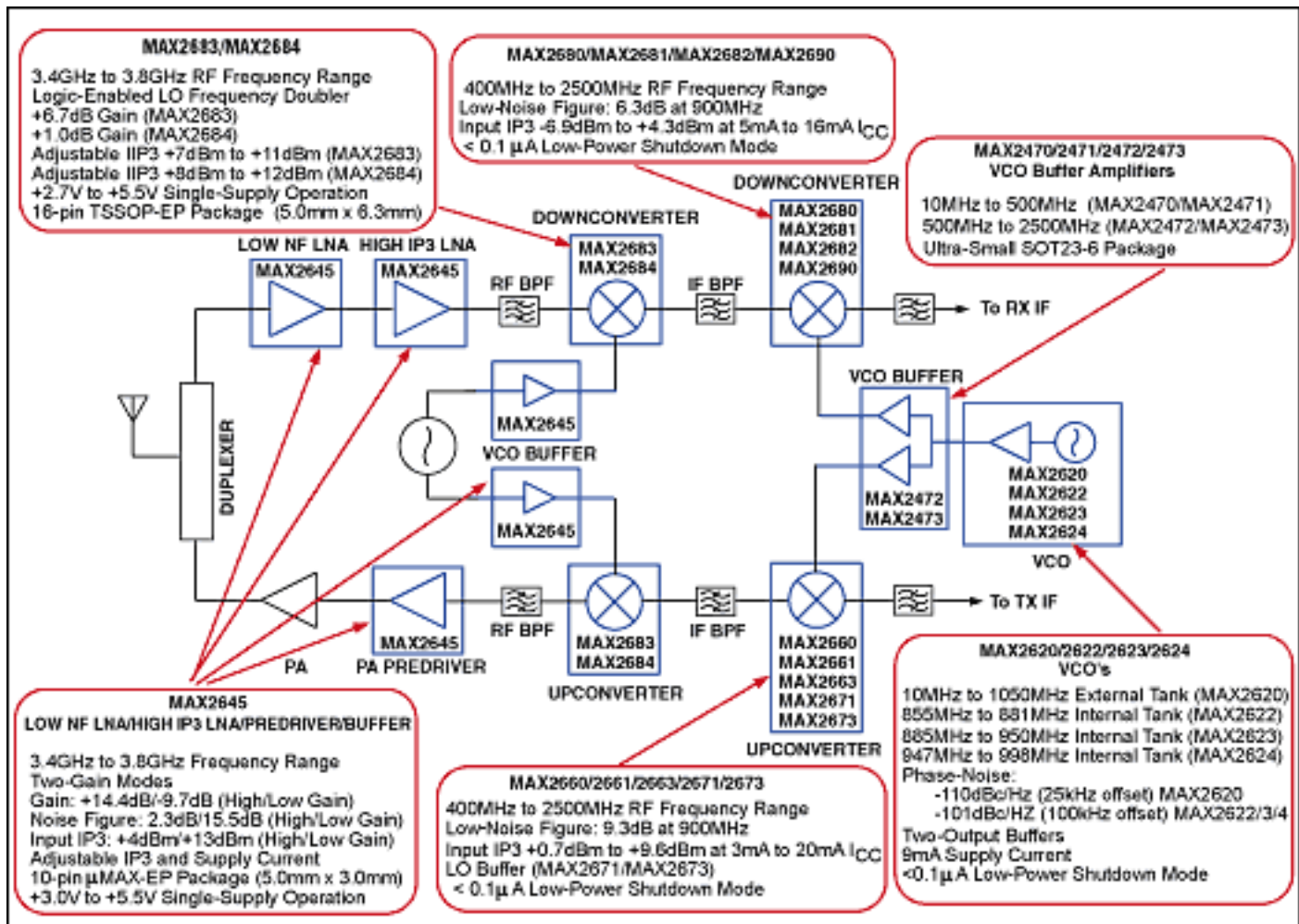

MAX2645: 3.4GHz to 3.8GHz SiGe Low-Noise Amplifier/PA Predriver/VCO Buffer

The MAX2645 is a versatile, low-noise, high-linearity amplifier designed for 3.4GHz to 3.8GHz wireless local loop (WLL), wireless broadband access, and digital microwave radio applications. The RF IC features an externally adjustable bias control, set with a single resistor, that allows the user to meet minimum linearity requirements while minimizing current consumption. The RF ICs high-gain, low-noise performance and adjustable input third-order intercept point (IIP3) allow it to be used as a very low-noise amplifier (LNA) in the receive path, a high-IP3 amplifier in the receive path, a PA predriver in the transmit path or as an LO buffer.

The MAX2645 RF IC features a logic-level gain control that provides a 25dB step reduction in gain, which improves IP3 performance for operation during high input signal level conditions. Supply current is reduced from 9mA in high-gain mode to 3mA in low-gain mode. The LNA also features a logic-controlled shutdown mode which reduces supply current to less than 0.1µA. Please refer to the [Quick View Data Sheet for the MAX2645 Silicon Germanium LNA](#) for further information.

Application Circuit	Supply Current (mA)		Gain (dB)		Noise Figure (dB)		Input IP3 (dBm)	
	High Gain Mode	Low Gain Mode	High Gain Mode	Low Gain Mode	High Gain Mode	Low Gain Mode	High Gain Mode	Low Gain Mode
Low NF LNA	9.2	2.7	14.4	-9.7	2.3	15.5	+4	+13
High IIP3 LNA	9.2	2.7	14.9	-10.7	2.6	16	+10.0	+15.5
PA Predriver	12	3.6	15.2	-9.7	2.6	16	+11.8	+16.2

MAX2683/MAX2684: 3.5GHz Downconverters and Upconverters with Selectable LO Doubler

The MAX2683/MAX2684 are super-high-performance, low-cost RF ICs intended for wireless local loop (WLL) and digital microwave radio (DMR) applications in the 3.4GHz to 3.8GHz frequency band. The MAX2683 is optimized for downconversion to IF frequencies between 100MHz and 400MHz, and allows both high-side and low-side local oscillator (LO) injection. The MAX2684 is optimized for IF frequencies between 800MHz and 1000MHz, and allows low-side LO injection. A logic-level control enables an internal frequency doubler on both devices, allowing the external LO source to run at full or half frequency. An internal LO filter reduces LO harmonics and spurious mixing. Refer to the application note "[The MAX2683 Low-Cost High-Performance 3.5GHz Upconverter](#)" for performance and applications information on use of the MAX2683/MAX2684 as an upconverting mixer.

The MAX2683/MAX2684 RF ICs feature an externally adjustable bias control, set with a single resistor, that lets the user trade supply current for linearity to optimize system performance. These RF ICs use a double-balanced Gilbert-cell architecture with single-ended RF and LO inputs and differential open-collector IF output ports. Differential IF ports provide a wideband, flexible interface for either single-ended or differential applications.

The MAX2683/MAX2684 RF ICs operate from a single +2.7V to +5.5V supply. The RF ICs are packaged in an 16-pin TSSOP-EP package with an exposed paddle for optimum performance at 3.5GHz. Please refer to the [Quick View Data Sheet for the MAX2683/MAX2684](#) for further information.

MAX2680/MAX2681/MAX2682/MAX2690: 400MHz to 2.5GHz, Low-Noise Silicon Germanium (SiGe) Downconverters

The MAX2680/MAX2681/MAX2682/MAX2690 miniature, low-cost, low-noise downconverters are designed for low-voltage operation and are ideal for use in portable communications equipment. Signals at the RF input port are mixed with signals at the local oscillator (LO) port using a double-balanced mixer. These downconverter mixers

operate with RF input frequencies between 400MHz and 2500MHz, and downconvert to IF output frequencies between 10MHz and 500MHz.

The MAX2680/MAX2681/MAX2682 RF ICs operate from a single +2.7V to +5.5V supply, allowing them to be powered directly from a 3-cell NiCd battery pack or a single lithium-ion cell. These RF ICs offer a wide range of supply currents and input intercept (IIP3) levels to optimize system performance. Additionally, each device features a low-power shutdown mode in which it typically draws less than 0.1 μ A of supply current. Consult the MAX2680/MAX2681/MAX2682 data sheet for IIP3 and supply current performance.

The MAX2680/MAX2681/MAX2682 RF ICs are manufactured on a high-frequency, low-noise, advanced silicon-germanium process and are offered in the space-saving 6-pin SOT23 package.

The MAX2690 features differential IF ports, which provides good linearity and low LO emissions, as well as providing compatibility with applications using differential IF filters, such as CDMA cellular phones. The mixer noise figure is 10dB at 900MHz.

The MAX2690 draws 16mA at $V_{CC} = 3V$ and operates from a +2.7V to +5.5V supply. A logic-controlled shutdown mode reduces the supply current to less than 1 μ A, making it ideal for battery-operated equipment. This device is offered in a miniature 10-pin μ MAX package. Please refer to the [Quick View Data Sheet for the MAX2680/MAX2681/MAX2682](#) for further information.

MAX2660/MAX2661/MAX2663/MAX2671/MAX2673: 400MHz to 2.5GHz Upconverters

The MAX2660/MAX2661/MAX2663/MAX2671/MAX2673 miniature, low-cost, low-noise upconverters are designed for low-voltage operation and are ideal for use in portable consumer equipment. Signals at the IF input port are mixed with signals at the local oscillator (LO) port using a double-balanced mixer. These upconverters operate with IF input frequencies between 40MHz and 500MHz, and upconvert to output frequencies as high as 2.5GHz.

These RF ICs offer a wide range of supply currents and output intercept levels to optimize system performance. Supply current is essentially constant over the specified supply voltage range. Additionally, each device features a low-power shutdown mode in which supply current is reduced to less than 1mA.

The MAX2660/MAX2661/MAX2663/MAX2671 RF ICs are offered in the space-saving 6-pin SOT23 package. For applications requiring balanced IF ports, choose the MAX2673 in the 8-pin μ MAX package. Please refer to the [Quick View Data Sheet for the MAX2660/MAX2661/MAX2663/MAX2671/MAX2673](#) for further information.

MAX2620: 10MHz to 1050MHz VCO With Buffered Outputs

The MAX2620 VCO combines a low-noise oscillator with two output buffers in a low-cost, plastic surface-mount, ultra-small μ MAX package. This device integrates functions typically achieved with discrete components. The oscillator exhibits low phase-noise when properly mated with an external varactor-tuned resonant tank circuit. Two buffered outputs are provided for driving mixers or prescalers. The buffers provide load isolation to the oscillator and prevent frequency pulling due to load-impedance changes. Power consumption is typically just 27mW in operating mode ($V_{CC} = 3.0V$), and drops to less than 0.3 μ W in standby mode. The MAX2620 operates from a single +2.7V to +5.25V supply. Please refer to the [Quick View Data Sheet for the MAX2620](#) for further information.

MAX2622/MAX2623/MAX2624: Monolithic Voltage-Controlled Oscillators

The MAX2622/MAX2623/MAX2624 self-contained voltage-controlled oscillators (VCOs) combine an integrated oscillator and output buffer in a miniature 8-pin μ MAX package.

The inductor and varactor elements of the tank circuits are integrated on-chip, greatly simplifying application of the part. In addition, the center frequency of oscillation and frequency span are factory preset to provide a

guaranteed frequency range versus control voltage. An external tuning voltage controls the oscillation frequency. The output signals are buffered by an amplifier stage (easily matched to 50Ω using only capacitors) to provide higher output power and isolate the devices from load impedance variations.

The MAX2622/MAX2623/MAX2624 operate from a +2.7V to +3.3V supply voltage and require only 9mA of supply current. In shutdown mode, the supply current is reduced to 0.1μA. Please refer to the [Quick View Data Sheet for the MAX2622/MAX2623/MAX2624](#) for further information.

MAX2472/MAX2473: 500MHz to 2500MHz VCO Buffer Amplifiers

The MAX2472/MAX2473 RF ICs are flexible, wideband, high reverse-isolation buffer amplifiers. The MAX2472 has dual open-collector outputs capable of delivering -5dBm into 50Ω while maintaining harmonic suppression below -25dBc. The MAX2473 has a single open-collector output with a bias control pin to vary output power from -10dBm to -2dBm while maintaining harmonic suppression below -25dBc. The MAX2472/MAX2473's combination of high reverse isolation and low supply current makes them ideal for applications requiring high performance with low power. The RF ICs feature high input impedance and open-collector outputs for maximum flexibility, enabling them to be used with a variety of oscillator topologies.

Both the MAX2472 and MAX2473 RF ICs operate from a single +2.7V to +5.5V supply. With $V_{CC} = +3.0V$ and -25dBm input power, the MAX2472 consumes 5.2mA, while the MAX2473 consumes only 2.7mA. Both RF ICs are available in a tiny 6-pin SOT23 package requiring minimal board space. Please refer to the [Quick View Data Sheet for the MAX2472/MAX2473](#) for further information.

μMAX is a registered trademark of Maxim Integrated Products, Inc.

Application Note 806: <http://www.maxim-ic.com/an806>

More Information

For technical questions and support: <http://www.maxim-ic.com/support>

For samples: <http://www.maxim-ic.com/samples>

Other questions and comments: <http://www.maxim-ic.com/contact>

Related Parts

MAX2470: [QuickView](#) -- [Full \(PDF\) Data Sheet](#)

MAX2471: [QuickView](#) -- [Full \(PDF\) Data Sheet](#)

MAX2472: [QuickView](#) -- [Full \(PDF\) Data Sheet](#)

MAX2473: [QuickView](#) -- [Full \(PDF\) Data Sheet](#)

MAX2620: [QuickView](#) -- [Full \(PDF\) Data Sheet](#) -- [Free Samples](#)

MAX2622: [QuickView](#) -- [Full \(PDF\) Data Sheet](#) -- [Free Samples](#)

MAX2623: [QuickView](#) -- [Full \(PDF\) Data Sheet](#) -- [Free Samples](#)

MAX2624: [QuickView](#) -- [Full \(PDF\) Data Sheet](#) -- [Free Samples](#)

MAX2645: [QuickView](#) -- [Full \(PDF\) Data Sheet](#)

MAX2660: [QuickView](#) -- [Full \(PDF\) Data Sheet](#)

MAX2661: [QuickView](#) -- [Full \(PDF\) Data Sheet](#)

MAX2663: [QuickView](#) -- [Full \(PDF\) Data Sheet](#)

MAX2671: [QuickView](#) -- [Full \(PDF\) Data Sheet](#)

MAX2673: [QuickView](#) -- [Full \(PDF\) Data Sheet](#)

MAX2680: [QuickView](#) -- [Full \(PDF\) Data Sheet](#)

MAX2681: [QuickView](#) -- [Full \(PDF\) Data Sheet](#)

MAX2682: [QuickView](#) -- [Full \(PDF\) Data Sheet](#)

MAX2683: [QuickView](#) -- [Full \(PDF\) Data Sheet](#)

MAX2684: [QuickView](#) -- [Full \(PDF\) Data Sheet](#)

MAX2690: [QuickView](#) -- [Full \(PDF\) Data Sheet](#)

AN806, AN 806, APP806, Appnote806, Appnote 806

Copyright © by Maxim Integrated Products

Additional legal notices: <http://www.maxim-ic.com/legal>