



APPLICATION NOTE 795

Designing Large Video-Crosspoint Systems Just Got Easier

Abstract: Maxim has raised the bar by announcing the next level of integrated video crosspoint integrated circuits (ICs). The flagship member of this new family is a fully buffered 32x16 analog crosspoint matrix, twice as large as the largest currently available. The switching portion alone is equivalent to 512 analog switches. The switching matrix is 100% non-blocking, which means any input can be connected to any output. Each input and output is buffered and all outputs can be individually set for high impedance disable or gain = 1V/V or 2V/V.

Analog video switching constitutes the heart of many systems. It plays a pivotal role in security video, video on demand, and other equipment that captures or distributes multiple analog-video signals. Designing the circuit boards that switch these signals can be challenging, because the designer must account for impedance matching, return loss, tilt effects, clamp levels, differential gain and phase errors, glitch energy, and other important issues.

A wrong decision in any of these areas affects the resulting video quality. When designing a very large system that switches several hundred or several thousand video signals, you must also consider crosstalk, signal degradation, insertion loss, EMI, physical size, and excessive heat. The historic design approach based on passive switches and IC op amps is challenging even for seasoned analog-video engineers. Today's highly integrated video-crosspoint ICs, however, enable the designer to produce more reliable systems faster and with less effort. Because most of the system's complexity resides in the IC, the designer can develop smaller systems that yield higher performance and greater profit.

New, Integrated, Video Crosspoint Matrix

Maxim has raised the bar by announcing the next level of integrated crosspoint ICs. The flagship member of this new family is a fully buffered 32x16 crosspoint matrix, twice as large as the largest currently available. As the first devices to achieve this level of integration, the new ICs pack a 32x16 matrix and other useful functions in a 144-pin TQFP form factor (**Figure 1**). The switching portion alone is equivalent to 512 analog switches. The switching matrix is 100% non-blocking, which means any input can be connected to any output. You can also connect any input to any number of outputs or even to all outputs simultaneously.

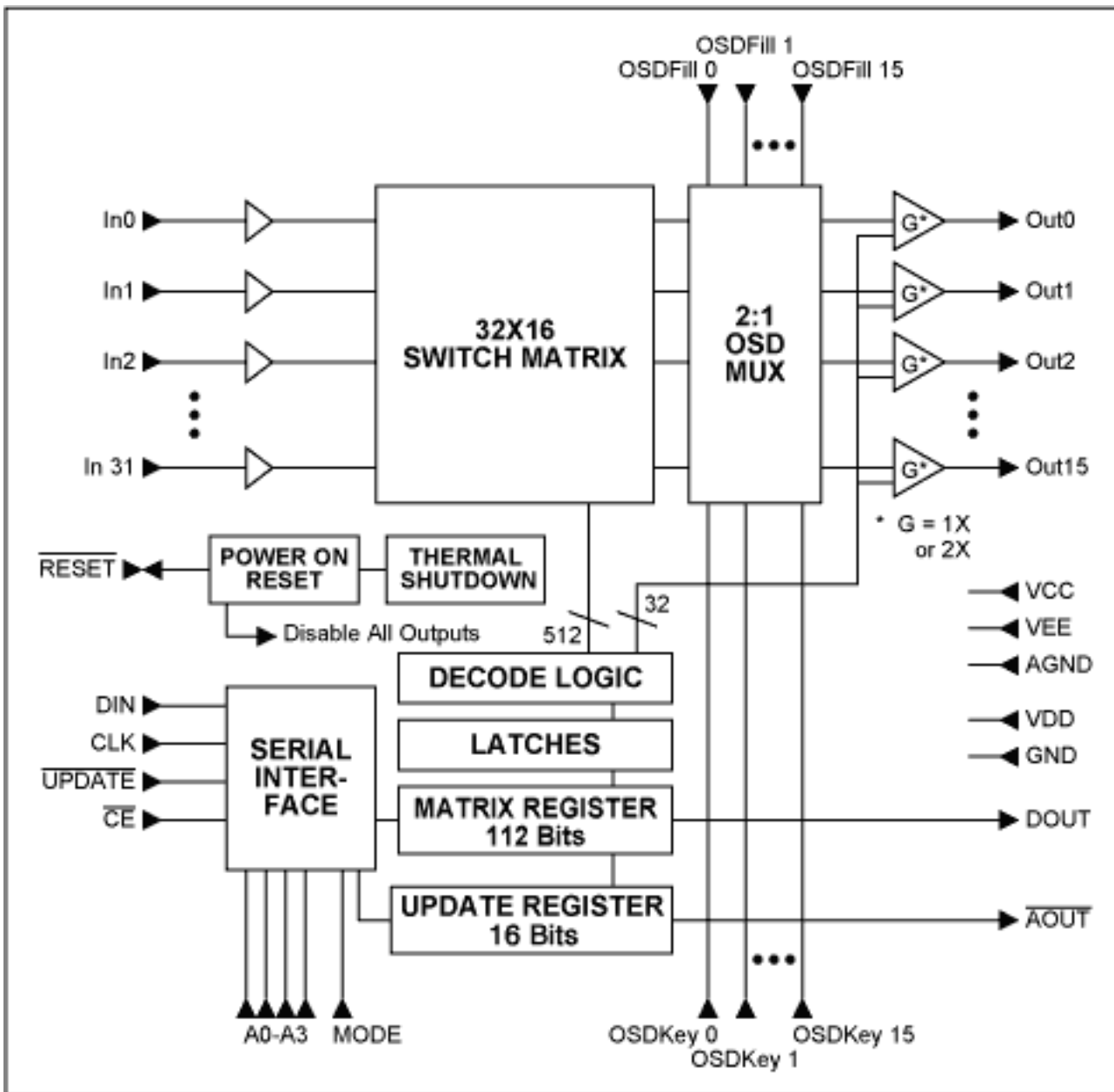

Figure 1. This block diagram illustrates functions within the MAX4358, a 32x16 video crosspoint matrix.

Fully Buffered

The MAX4358, with its buffered inputs and outputs, is a big improvement over passive switching matrices. The input buffer amplifiers provide high-impedance inputs that allow use of simple resistor-diode input clamps. Each output can drive a standard 75Ω video cable with 75Ω back-match resistor (150Ω total), with typical differential gain and phase errors of 0.05% and 0.1°, respectively.

The family consists of a 32x16 crosspoint with OSD insertion capability in a 144-pin TQFP package (MAX4358), a 32x16 crosspoint in a 128-pin TQFP (MAX4357), a 16x16 crosspoint with OSD insertion capability in a 128-pin TQFP (MAX4356), and a 16x16 crosspoint in a 100-pin TQFP (MAX4355).

These devices are best applied in medium- to large-capacity security video systems, which typically have one hundred to several thousand camera inputs, and tens to hundreds of outputs. Other good applications are "near-video-on-demand" systems and pay-per-view movie services. Again, typical equipments feature hundreds to thousands of destinations and ten to one hundred input sources. The goal of these systems is to automatically route a selected movie source to the room from which the request was made.

Building Large Video Switching Systems

The MAX4358 easily creates larger switching matrices. The number of ICs required to implement a matrix depends on the number of input channels, the number of outputs, and whether the array is non-blocking or has switching limitations. Another major factor is the size of the integrated building block. Using a 32x16 device instead of a 16x16 device lets you implement large arrays with half the number of ICs.

The most straightforward technique for implementing non-blocking matrices is to arrange the building blocks in a grid. The inputs connect to each vertical bank of devices in parallel with other banks, and the outputs of each building block in a vertical column connect together in a wired-OR configuration (**Figure 2**).

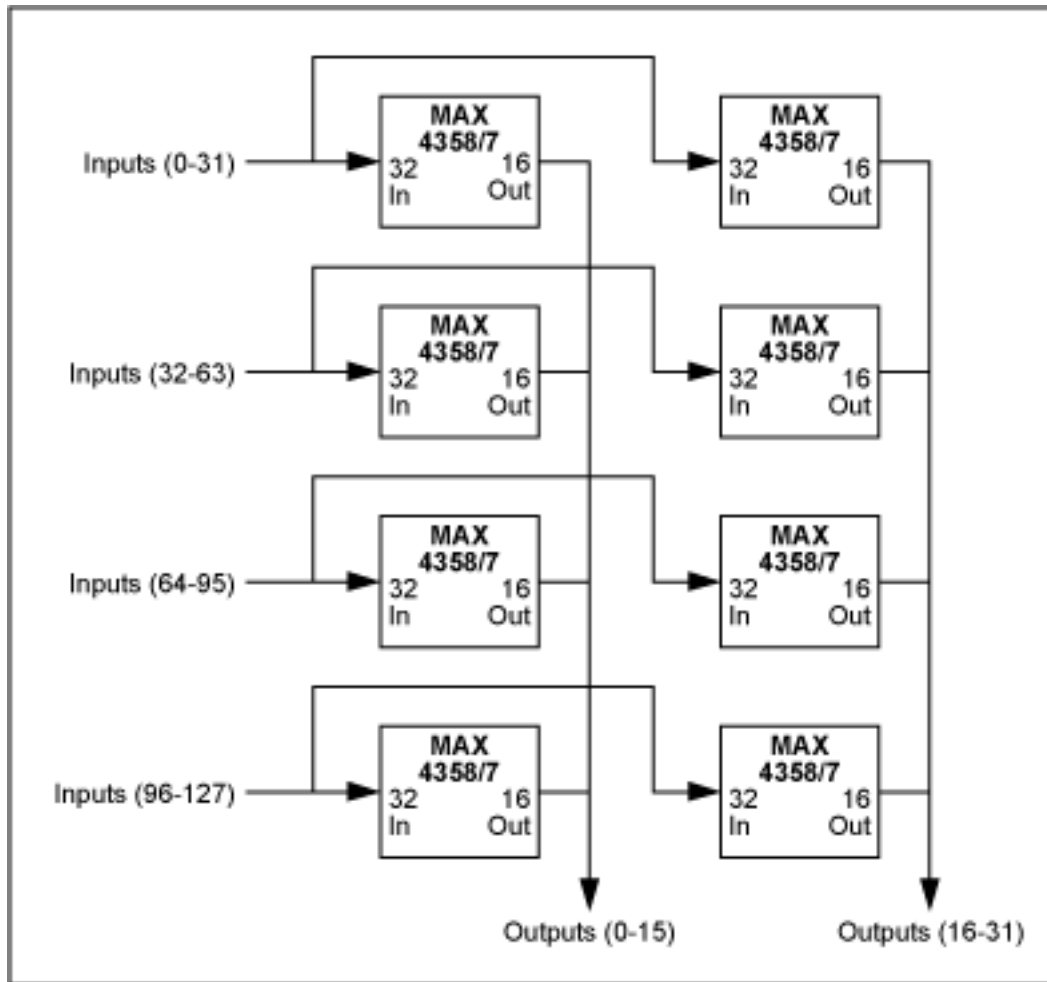

Figure 2. This diagram shows a 128-input, 32-output nonblocking array implemented with 32x16 crosspoint devices.

The wired-OR connection is possible because the IC's output buffers can be placed in a disabled or high-impedance output state that maintains low output capacitance with maximum impedance vs. frequency. These characteristics help minimize the adverse loading effects of "off" outputs. Connecting the ICs in this manner allows any input to be routed to any output, and you construct larger arrays by extending the connection technique to more devices.

Driving a Capacitive Load

As you can see, the above example requires many outputs to be wired together. As a result, each output buffer sees not only the normal load impedance but also the disabled impedance of all the other outputs connected to that node. This impedance has a resistive and a capacitive component. The resistive component reduces the total effective load for the driving output, but with minimal impact on performance because the output buffers easily handle the minimal increase in load.

The potentially more significant effect of a wired-OR connection is the capacitance. All disabled outputs add together, so the amount depends on the size of the matrix. A larger matrix has longer pc-board traces, which add even more capacitance. Consequently, the output buffers on these devices are designed to maintain good ac response (0.1dB gain flatness to 12MHz) while driving more than 30pF. Capacitance seen by the output can exceed this amount in some cases, if enough outputs are wired together in a large array. Several methods can improve the situation if performance loss is excessive.

First, you can reduce the number of outputs wired together by adding more crosspoint devices (**Figure 3**). Notice that additional devices in a second bank multiplex the signals, thereby reducing the number of wired connections. Another solution is to isolate the load from the output by adding a small (5Ω to 30Ω) resistor in series with the output, before the capacitive load. This added resistor enables the outputs to drive virtually unlimited capacitance, but also (as a minor drawback) it forms a lowpass filter with the parasitic capacitance to ground. A single RC network has no effect on video-frequency performance, but large systems may include a cascade of many RCs in series. The cumulative effect can be a slight rolloff at high frequency that causes a slight "softening" of the picture. This effect may be acceptable in a typical security video application, but for higher performance several options are available. One is to design the pc-board traces associated with outputs so they exhibit some inductance. By routing traces in a repeating "S" configuration, the traces nearest each other have a mutual inductance that increases the total inductance. Series inductance causes the amplitude response to peak at higher frequencies, thereby offsetting the rolloff from parasitic capacitance. As an alternative, you can achieve the same effect by adding a small-valued inductor. The optimum arrangement is usually a combination of these two approaches.

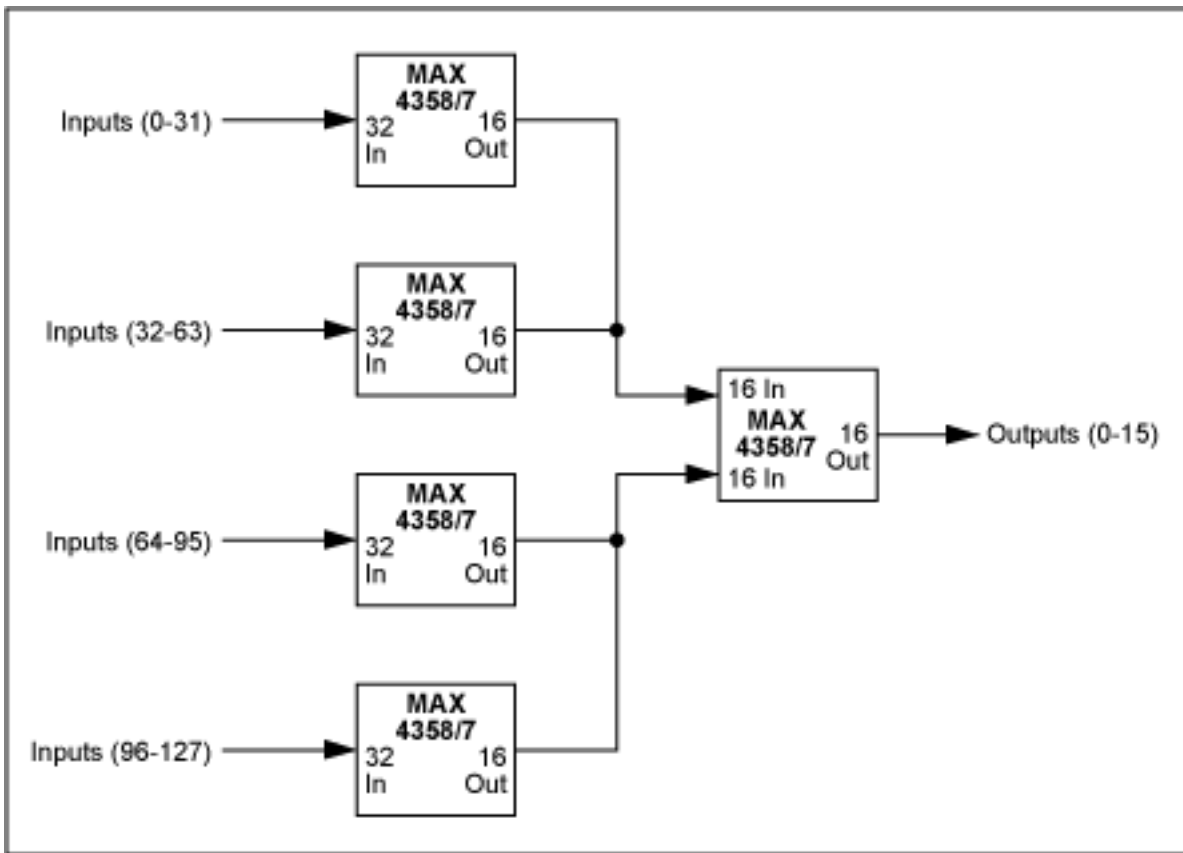

Figure 3. This 128x16 nonblocking matrix features reduced capacitive loading.

Crosstalk and Board Routing

Improper routing of signals on a large video matrix can cause multiple performance problems, but the most difficult issue associated with routing is crosstalk rejection. Like most ICs, these matrix devices have very good inherent crosstalk performance. For all ICs in the family, crosstalk rejection is typically -62dB . Bad pc-board layout can degrade this performance by 20dB or more, so you should pay close attention to the board layout. For best crosstalk performance,

- *Place ground isolation between the critical (long) pc-board traces that carry signals.* The added traces act as a shield to potential interfering signals. Note that crosstalk is encouraged both by side-by-side traces and by traces separated only by a pc-board layer. The potential coupling between layers is a function of the board's thickness and of the dielectric of its material.
- *Maintain controlled-impedance traces.* Designing pc-board traces to be 75Ω transmission lines dramatically reduces a potential source of crosstalk by lowering the trace impedance. As a tradeoff, more components are required to set the termination impedance and more power is dissipated as the buffer outputs drive lower impedances.
- *Minimize ground current interaction.* A good ground-plane strategy minimizes this problem.

In addition to crosstalk, another key issue is isolation, which is defined as the amount of undesirable feedthrough from input to output with the output disabled. The IC pins are arranged for excellent isolation: with inputs on one side and outputs on the other, the isolation is greater than -110dB at 6MHz . For users, the only concern is external: coupling via pc-board traces and via common power-supply connections. Coupling through the power supply depends on the quality and location of bypass capacitors. Take care to use appropriate low-impedance components, and locate them as close to the IC as possible. Taking reasonable care to avoid routing inputs near outputs should ensure good isolation.

Power in Large Systems

A big concern in most medium-to-large security video installations is the heat generated by power dissipation in the switching matrix. Many such systems operate under non-ideal conditions, installed as an afterthought in small rooms and storage closets. Large amounts of heat generated in a small space can raise the ambient temperature to levels uncomfortable for service personnel. For this reason and for the obvious power-supply savings, Maxim crosspoint devices require much less power than do the existing alternatives (less than one third at the minimum operating supply voltage). Unlike competitive devices that operate only on $\pm 5\text{V}$, Maxim crosspoint devices operate from $\pm 5\text{V}$ down to $\pm 3\text{V}$, or from 5V alone.

Drive a Cable or PC-Board Interconnect with the Same Device

To handle different load-driving situations, the output buffers on Maxim crosspoint devices can be programmed via the serial interface for a gain of 1V/V or 2V/V . The 1V/V configuration is used for driving short ($< 3\text{cm}$) high-impedance "local" traces on the pc board. For driving cables or 75Ω transmission-line traces, set the output-buffer gain to 2V/V and place a 75Ω resistor in series with the output (this is the output configuration most common in video systems). With gain set at 2V/V , the series resistor and 75Ω load impedance act as a voltage divider that cuts the signal in half, transmitting a standard 1V video signal down the cable. The series 75Ω resistor (called the back match, reverse termination, or series termination) presents a 75Ω matching impedance for potential reverse signals called reflections. The matched impedance eliminates or greatly reduces reflections.

On-Screen Display Insertion

In video switching systems it is useful (and often mandatory) to insert into each channel some information about the video signal source, for eventual viewing on a monitor. Commonly called on-screen-display, or OSD, this info would typically include the location (of a camera, for instance), and the time and date. A conventional technique for implementing OSD places the OSD devices in series with the switch matrix outputs (**Figure 4**). Two of Maxim's new crosspoint devices include the circuitry necessary for inserting these on-screen graphics and characters. This capability is achieved with fast, 2:1 analog multiplexers associated with each of the 16 outputs, as shown in Figure 1. The multiplexers switch in 40ns typical, which is much less than the width of a single pixel. Access to these fast switches is through an additional 16 dedicated analog inputs named OSD Fill, and 16 dedicated control lines named OSD Key.

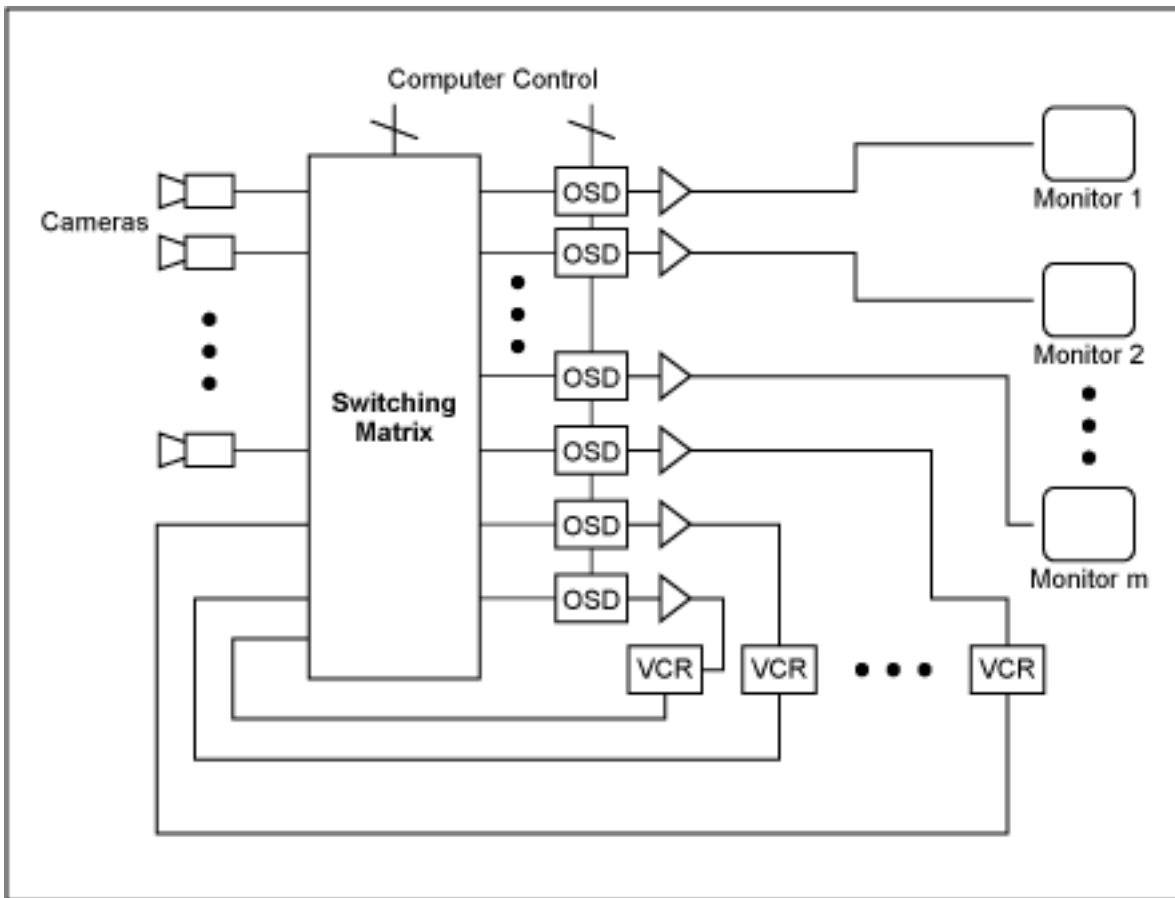

Figure 4. A conventional technique for implementing OSD places the OSD devices in series with the switch matrix outputs.

The analog video signal representing a graphic or character to be inserted is applied to the OSD Fill input that corresponds to the output where an on-screen display is to be added. You then supply an appropriate timing signal to the OSD Key input. A logic low on the OSD Key pin connects the signal on the OSD Fill input to the output, and a logic high connects regular video to the output. This switching action is repeated pixel by pixel for each scan line, allowing arbitrary graphics or any synchronized video signal to be inserted on the screen. This technique for inserting on-screen display information (**Figure 5**) is a radical departure from the conventional approach.

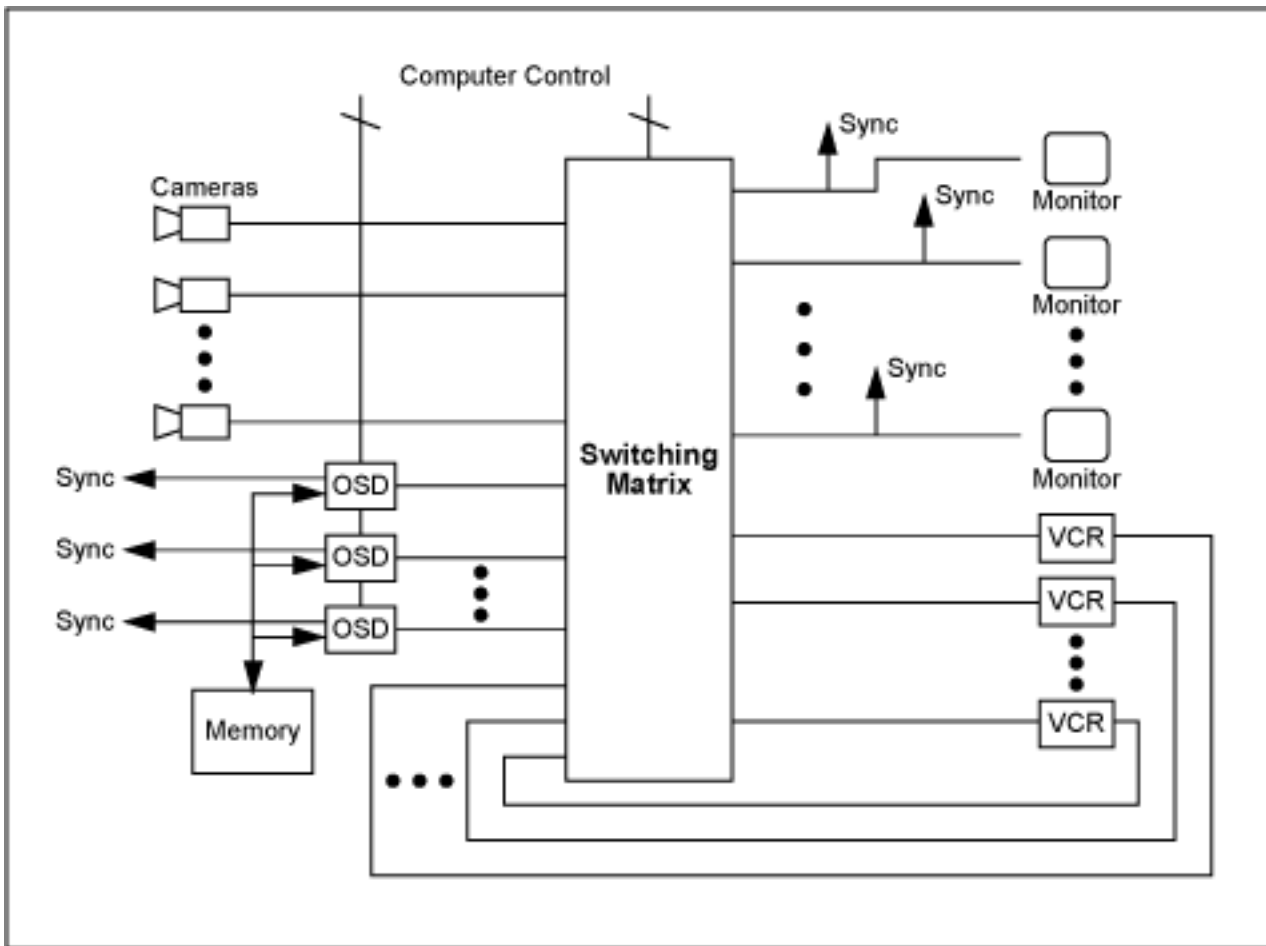

Figure 5. The new and improved on-screen display (OSD) positions OSD devices in front of the switching matrix.

With this approach, OSD information is now inserted before the switching matrix. The resulting architecture eliminates the complexity and cost of output buffers following the OSD devices, which were required because OSD devices cannot drive the cable directly. The new approach doesn't require output buffers because crosspoint devices can drive the cable directly. The video signal in current systems must pass through the OSD device and then through the output buffer. Because current OSD devices can have poor video pass-through, a second benefit of the new ICs is improved signal quality.

Unique Control Interface

The digital interface on Maxim crosspoint devices communicates with a host processor via a standard serial SPI interface, in two ways. First, it "talks" to the host in an individual address mode. In this mode the address is set by strapping four external pins on the package. The host then sends a 16-bit word consisting of four chip-address bits, 11 payload bits, and (to make the word two bytes long) one "don't care" bit. The 11-bit data payload consists of four bits to select the output to be programmed, five bits to select the input to be connected to that output, one bit to set the gain of the output buffer, and one bit to control whether that output is put into disable mode. This method programs (configures) the matrix one output at a time until all 16 outputs are configured for each crosspoint device in the matrix system.

Second, the interface has an alternate mode in which many crosspoint devices are addressed in series, with each data-out port going to the data-in port of the next device. Multiple devices are programmed with one long programming word. Within this long data word, the first bit is the LSB of the device most remote in the chain, and the last bit is the MSB of the device closest in the chain (a programming mode called daisy chaining). The length of the long data word equals 112 bits times the number of crosspoint devices to be programmed in series.

This programming method is most often used to configure the switching matrix at startup. The initialization word sequence can be read from system memory and sent to the interface as one continuous word, thereby simplifying the initialization program or reducing processor overhead during the equipment's power-on phase, when the processor must execute many tasks in initializing the system.

The two programming modes are selected by a toggling a single control line high or low. Both modes operate with the same physical board layout. Thus, you can program the IC at start-up by daisy chaining and sending one long data word, and immediately address and update individual locations in the matrix. As a result, you can implement two different serial addressing schemes with no extra pins and no changes in the board layout!

Summary

This new family of crosspoint devices eases the design of video-matrix switching systems while providing higher performance and more functionality. The result is physically smaller than existing systems, and produces far less heat.

VIDEO DESIGNERS: [Join our E-mail-based Discussion Group for Analog Video Designers.](#)

Application Note 795: <http://www.maxim-ic.com/an795>

More Information

For technical questions and support: <http://www.maxim-ic.com/support>

For samples: <http://www.maxim-ic.com/samples>

Other questions and comments: <http://www.maxim-ic.com/contact>

Related Parts

MAX4355: [QuickView](#) -- [Full \(PDF\) Data Sheet](#)

MAX4356: [QuickView](#) -- [Full \(PDF\) Data Sheet](#)

MAX4357: [QuickView](#) -- [Full \(PDF\) Data Sheet](#)

MAX4358: [QuickView](#) -- [Full \(PDF\) Data Sheet](#)

AN795, AN 795, APP795, Appnote795, Appnote 795

Copyright © by Maxim Integrated Products

Additional legal notices: <http://www.maxim-ic.com/legal>