

APPLICATION NOTE 791

Passive Differential IF Filters for the MAX2360/61 Transmitter ICs

Abstract: Clarifies the design of passive transmit IF filters for application with MAX236X integrated circuits (ICs) using differential topology. Sample design uses 600 source impedance and 400 Ω termination. The center frequency is 130MHz, and the bandwidth is 16MHz. Desired stop-band attenuation is -25dB at 90MHz and 200MHz. Bias path constraints force two inductors to provide the pull-up function. Simulation results are supplied, along with references.

Additional Information:

- [Wireless Product Line Page](#)
- [Quick View Data Sheet for the MAX2360/MAX2362/MAX2364](#)
- [Applications Technical Support](#)

Introduction

Much confusion surrounds the design and implementation of IF (intermediate frequency) filters with differential CDMA (Code Division Multiple Access) transmitter ICs, such as the MAX2360 or MAX2361. Filter textbooks are replete with example after example of single ended filters, and balanced filter implementation is left to the engineer's imagination. This application note describes the design of a sample 130MHz differential IF filter for use with the MAX2360, and shows how to couple the filter to the IF outputs and inputs for most efficient circuit operation. Simulation results are presented showing 16MHz bandwidth, 9.8dB loss, and 25dB attenuation at 100 and 183MHz.

The MAX2360 is a highly integrated transmitter IC, containing the IF frequency synthesizer, IF quadrature modulator, image reject RF upconverter, variable gain IF and RF amplifiers, power amplifier (PA) drivers, RF frequency synthesizer, and a serial bus interface for processor control. The IC was originally targeted towards IS-95 CDMA cell phone applications, and meets those needs in a small 48-pin TQFP form factor. More recent versions of the product (MAX2361, for example) are in the QFN package. All of the issues addressed in this application note apply to the newer versions, which also incorporate differential IF interfaces.

The IF interface detail shown in **Figure 1** gives the user a schematic representation of the IF outputs and inputs.

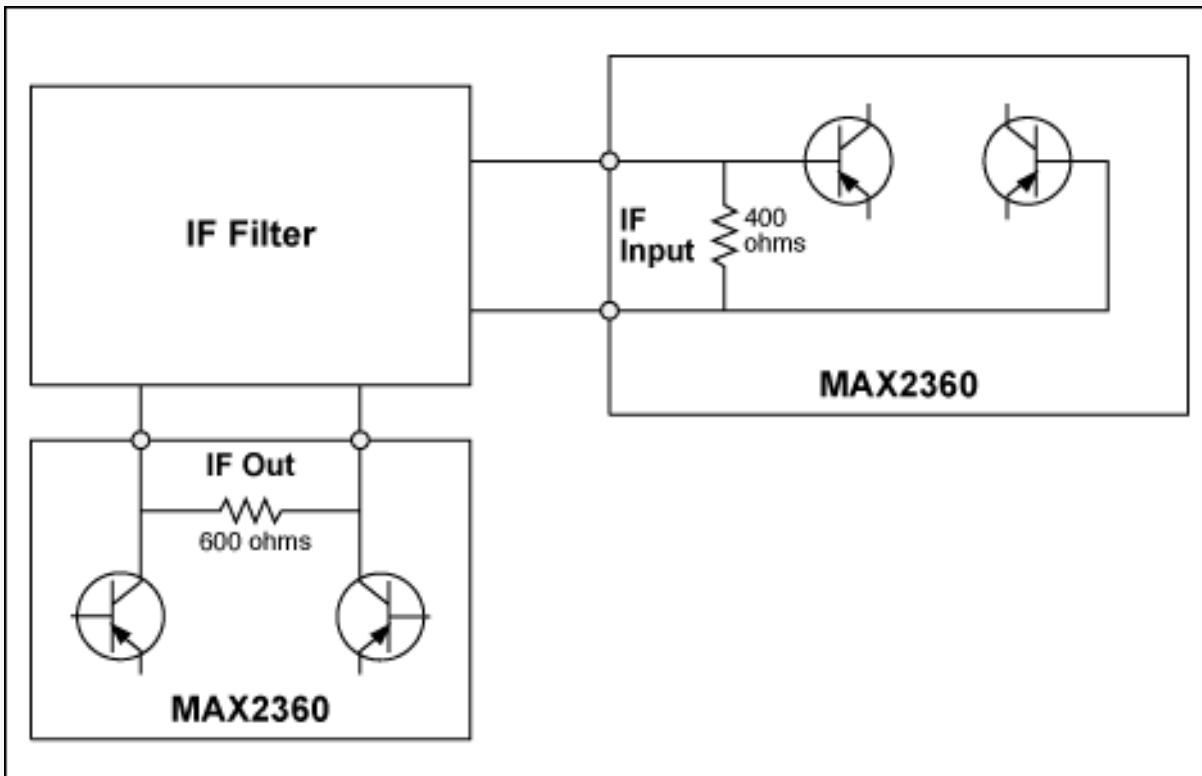

Figure 1. MAX2360 IF Filter Interface with balance signal path.

The output and input impedances are set by internal resistances: 600Ω at the output pins, and 400Ω at the input pins. These impedance levels represent an impedance which optimizes the performance of bipolar amplifiers being supplied from ~3V. Users applying SAW (surface acoustic wave) filters with 1k ohm input and output impedance will design matching networks to obtain the correct filter performance and power transfer. Recent CDMA systems have moved away from using SAW filters in the transmitter IF path, as the SAW filter added to the parts cost and resulted in an over-design of the transmitter spectral quality. To reduce the parts cost, new CDMA designs replace the SAW filter with passive LC designs, necessitating the design of a differential LC filter.

Example Single Ended Band Pass Filter Design

Target specifications for the IF filter are as follows:

Center Frequency, $f_0 = 130\text{MHz}$

3dB Bandwidth, $f_c = 16\text{MHz}$

Impedance $R_0 = 500\Omega$

Butterworth response

Stop band attenuation: ~25dB at 90MHz and 200MHz

Design Procedure

The order of the filter must be determined. To do this, the stop band frequencies are normalized relative to the center frequency and the bandwidth, for both the high side case and the low side:

$$\text{LOW SIDE} = 2 \times (130\text{MHz} - 90\text{MHz})/16\text{MHz} = 5.0$$

$$\text{HIGH SIDE} = 2 \times (200\text{MHz} - 130\text{MHz})/16\text{MHz} = 8.75$$

These normalized values are used with a standard Butterworth loss graph to estimate the required order of the filter. Both high side and low side frequencies are considered to determine the most restrictive limit. In the case being considered here, the low side limit of 5.0 indicates that a Butterworth filter with order 2 is required to provide 25dB attenuation at 90MHz. Consult a table of normalized Butterworth element values and note that the capacitor is 1.414 Farads and the inductor is 1.414 Henrys. **Figure 2** shows the two element normalized low pass filter.

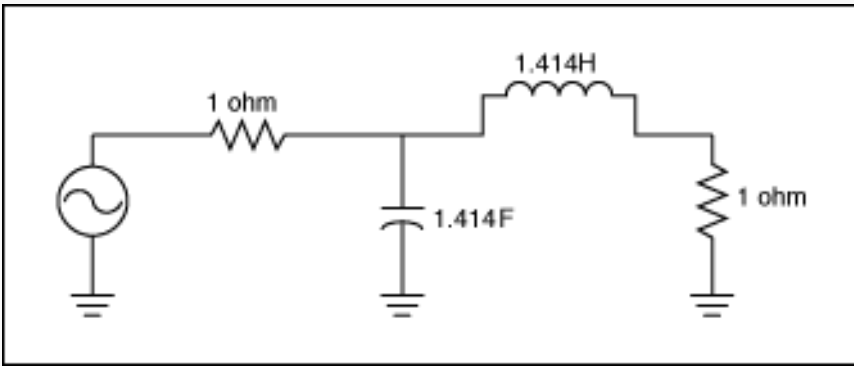

Figure 2. Normalized Butterworth $N=2$ low pass filter.

This low pass filter must now be transformed to a bandpass topology and scaled to 500Ω impedance. (Note: the 500Ω impedance was chosen for simplicity in this example, as it is a compromise between the 600Ω source impedance and the 400Ω filter termination. This mismatch introduces a small error that is ignored in this application note.)

To complete the transformation, the loaded Q of the filter is calculated:

$$Q_L = 130\text{MHz}/16\text{MHz} = 8.125$$

At this point in the design process, the issue of practical component values must be considered. If this is not done, an inappropriate topology will likely be chosen. Based on experience, the impedance level, and the center frequency, the topology shown in **Figure 3** was chosen. It features two parallel resonant LC tank circuits coupled through a series capacitor. This topology also uses few inductors, and is easy to convert to balanced operation.

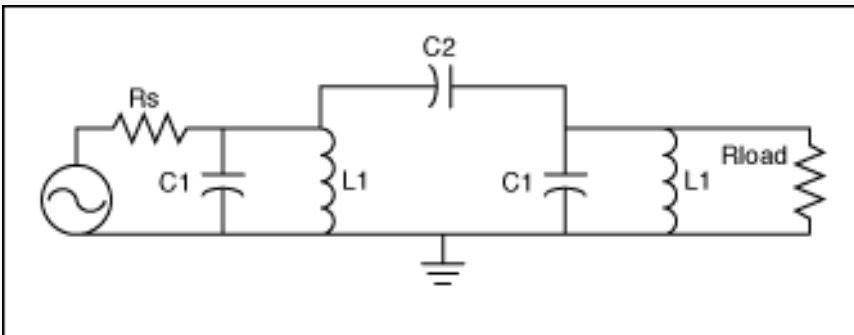

Figure 3. Bandpass filter topology.

The reference listed by White contains a valuable table (7.2) that suggests which filters can be built based on filter topology, loaded Q , center frequency and impedance level. Some modern filter design software packages also offer the same information, which can be of immense value for the beginning filter designer.

The first element to compute is the coupling capacitor, $C2$.

$$C2 := \frac{1}{2 \cdot \pi \cdot f_0 \cdot R_0} \cdot \sqrt{\frac{C_N}{L_N}} \quad C2 := \frac{1}{2 \cdot \pi \cdot 130 \cdot 10^6 \cdot 500} \cdot \sqrt{\frac{1.414}{1.414}} \quad C2 = 2.449 \cdot 10^{-12}$$

Equation 1

$$C1 := \frac{C_N}{R_0 \cdot 2 \cdot \pi \cdot f_c} - C2 \quad C1 := \frac{1.414}{500 \cdot 2 \cdot \pi \cdot 16 \cdot 10^6} - C2 \quad C1 = 2.568 \cdot 10^{-11}$$

Equation 2

$$L1 := \frac{R_0}{L_N \cdot Q_L \cdot 2 \cdot \pi \cdot f_0} \quad L1 := \frac{500}{1.414 \cdot 8.125 \cdot 2 \cdot \pi \cdot 130 \cdot 10^6} \quad L1 = 5.328 \cdot 10^{-8}$$

Equation 3

R_0 is the characteristic impedance of the final filter, in Ω .

Q_L is the loaded Q of the filter.

f_0 is the center frequency of the filter, in Hz.

f_c is the 3dB bandwidth of the filter, in Hz.

The diagram in **Figure 4** shows the current state of the filter design, after scaling for impedance and frequency:

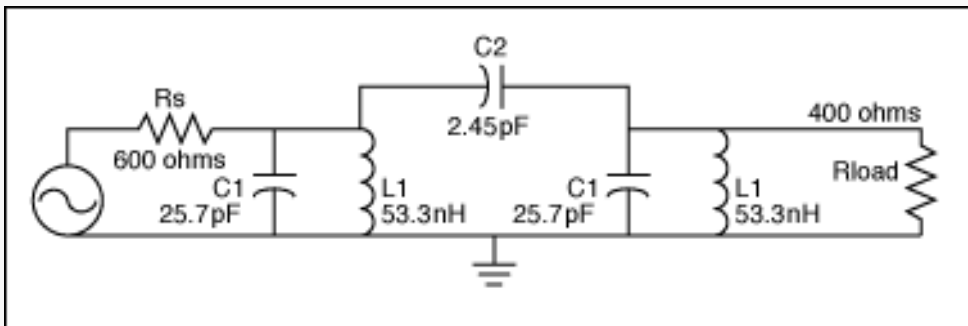

Figure 4. Scaled 130MHz bandpass filter, single ended.

It is a good idea to simulate the filter to catch computation errors or oversights in the design process. A common SPICE based simulator was used to confirm the design. The insertion loss, bandwidth and shape factor were simulated, with an inductor Q of 50. The response appeared close to the desired result.

The last steps in the filter design must tailor the topology for use with the MAX2360. Two requirements must be met for this application:

1. A DC path must exist from the IF output pins to the +DC supply.
2. The filter must present differential (balanced) impedance at both ends.

The required DC path is provided by splitting the inductor into two inductors, each of ~ 26.6 nH. The transformation to differential operation is easily accomplished. The filter is already scaled to the correct frequency and impedance level. All that remains is to translate the "ground" of the filter in such a manner as to allow the two signal paths to become symmetrical with respect to ground. As is shown in **Figure 5**, this is done by adding another capacitor in what was the ground path between the two tank circuits, becoming a mirror image of C2. The value of the additional capacitor is determined by knowing that the resonant frequency of each tank circuit must stay the same as the single ended design, which is 130MHz in this example. The resonance of the single ended tank is set by C1, C2 and L1. In the final

differential configuration, the resonance is set by L1, C1 and the effect of two C2 capacitors in series. Based on this model, the coupling capacitor in the differential mode filter is simply twice the value used in the single ended topology! Many filter texts omit this topic. It is presented here in heuristic form only. A few minutes with a simulator will convince the reader that this is in fact a valid method for transforming this single ended filter to differential mode. Determined engineers are welcome to write the equations for this filter topology and prove the transformation.

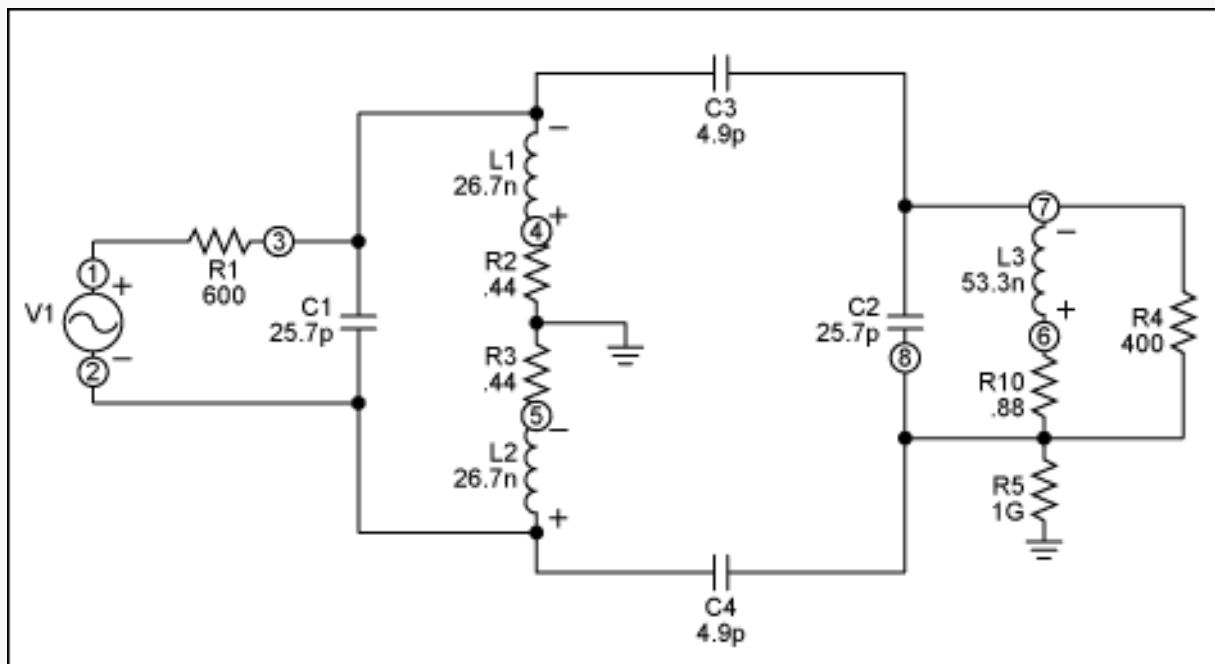

Figure 5. Differential 130MHz bandpass filter for simulation with split input inductor and finite Q.

The final filter topology is shown in Figure 5. Note the split inductors on the input side, and the balanced configuration. The circuit in Figure 5 was simulated with $Q = 50$ inductors, modeled here with a small resistance in series with each inductor.

{Note: the Simulator assigns reference designators. They do not correspond with the actual schematic designations in this application note.}

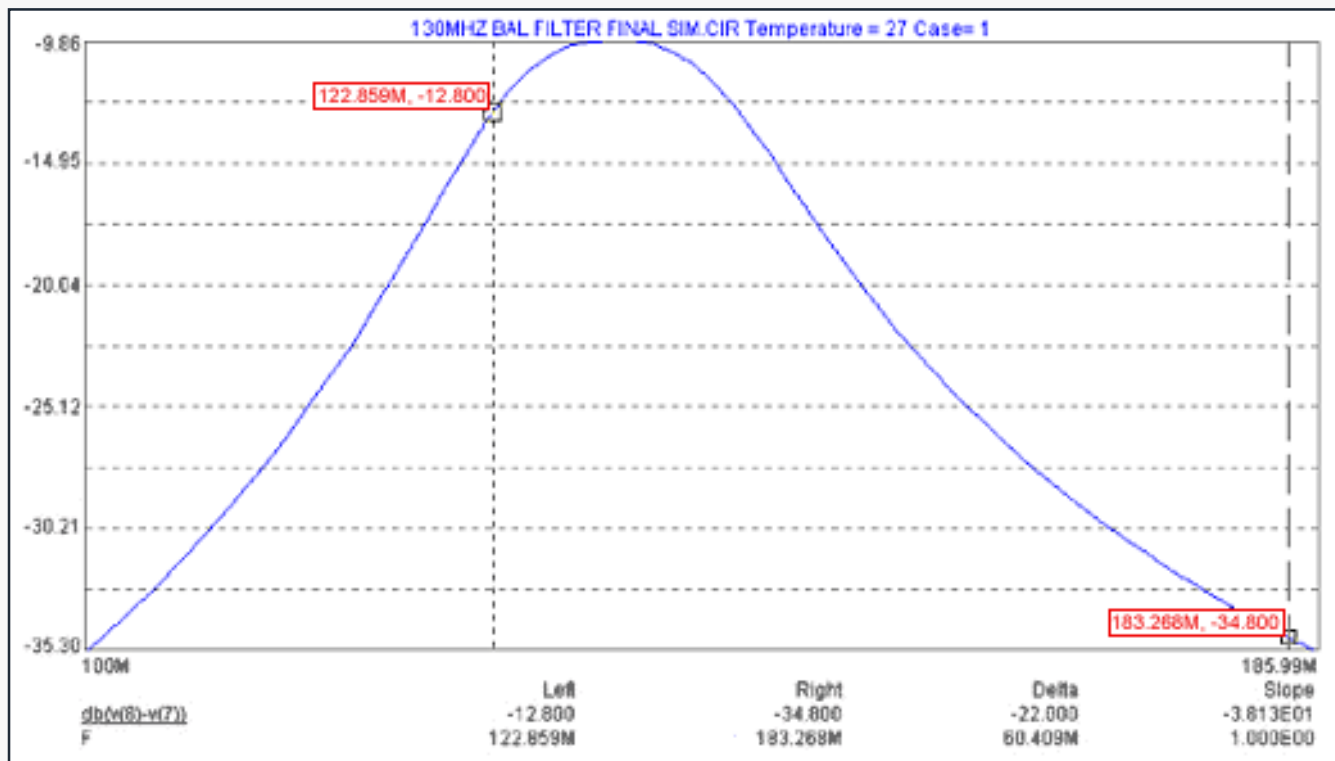

Figure 6. Simulated Filter output amplitude in dB versus frequency.

Figure 6 presents the simulated output swept amplitude response. The insertion loss is 9.8dB, and the 3dB bandwidth

is ~16MHz, nicely centered about 130MHz. The response is down 25dB at ~100MHz and 183MHz. Some improvement in the filter shape may be possible by narrowing the design target bandwidth below 16MHz. This will make the component selection much more critical, forcing a move to higher tolerance and more stability in the inductors and capacitors, in order to insure that the desired IF pass band is not attenuated. As narrower 3dB bandwidth is sought, the Q of the inductors will increase to keep insertion loss reasonable, and slightly modified filter design methods ("pre-distorted") should be employed. Narrow bandwidth will also exacerbate group delay distortion of the transmitted signal. It is simpler to keep the filter bandwidth as wide as possible and still meet the required attenuation in the stop band.

To complete the design, the filter needs to be integrated with the MAX2360 transmitter IC. The final portion of the schematic is shown below in **Figure 7**. Note that some work remains in this example, as circuit board strays have not been considered. Stray capacitance at the input and output of the filter can be compensated by reducing the values of C1. Adjusting C1 is also a way to compensate for inductor self resonant frequency, which should be of little impact in a filter designed for 130MHz operation with values less than 100nH. Stray coupling between the input and output are compensated by reducing the value of C2 on both sides of the filter.

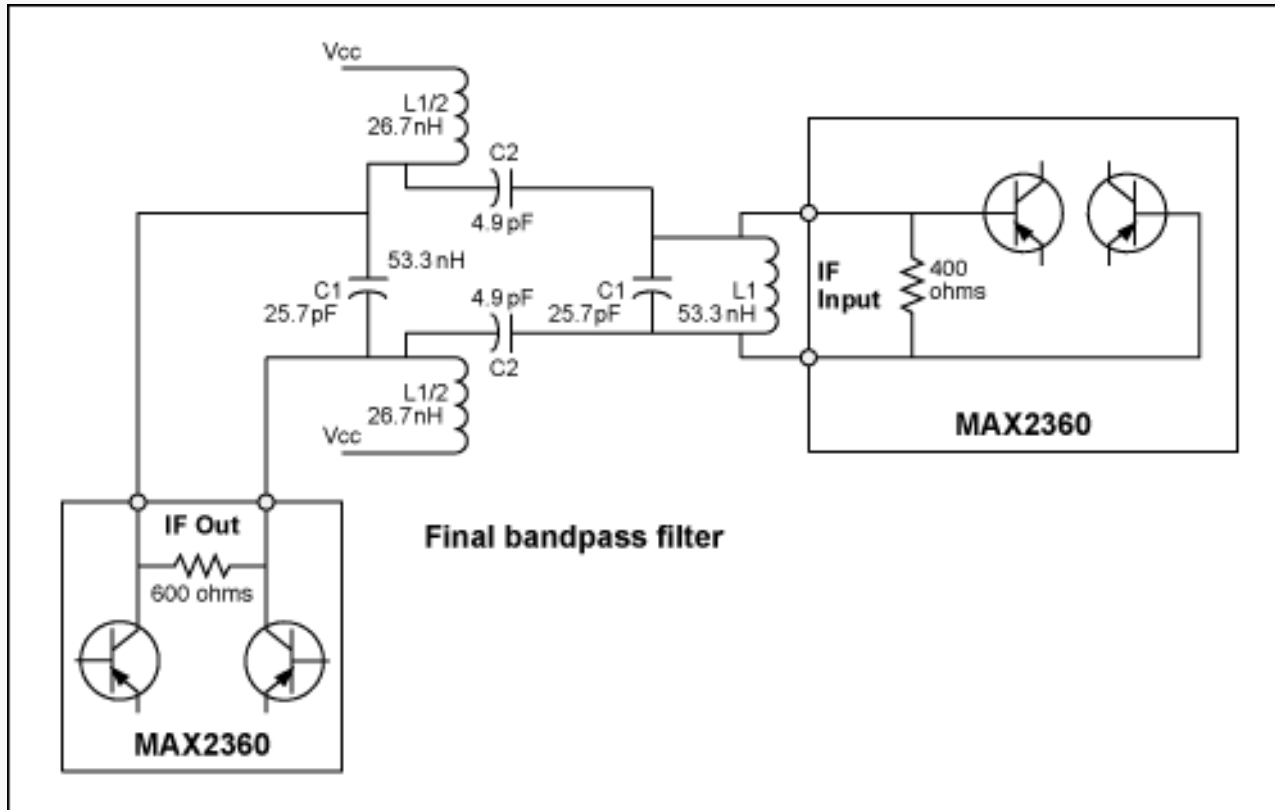

Figure 7. Filter integrated with the MAX2360.

References

1. White, Donald R. J., *A Handbook on Electrical Filters (Synthesis, Design and Applications)*, Don White Consultants, Inc., Gainesville, Virginia, 1980.
2. Zverev, Anatol I., *Handbook of Filter Synthesis*, John Wiley & Sons, Inc., New York, 1967.

Related Parts

MAX2360: [QuickView](#) -- [Full \(PDF\) Data Sheet](#)

MAX2361: [QuickView](#) -- [Full \(PDF\) Data Sheet](#) -- [Free Samples](#)

Automatic Updates

Would you like to be automatically notified when new application notes are published in your areas of interest? [Sign up for EE-Mail™](#).

Application note 791: www.maxim-ic.com/an791

More Information

For technical support: www.maxim-ic.com/support

For samples: www.maxim-ic.com/samples

Other questions and comments: www.maxim-ic.com/contact

AN791, AN 791, APP791, Appnote791, Appnote 791

Copyright © by Maxim Integrated Products

Additional legal notices: www.maxim-ic.com/legal