

APPLICATION NOTE 749

Improving Receiver Intercept Point Using Selectivity

Abstract: The receiver's intermodulation spurious response attenuation is a measure of the receiver's ability to receive a modulated input RF signal frequency on its assigned channel frequency in the presence of two interfering CW tones. These tones are separated from the assigned input signal frequency such that the n th-order mixing of the two undesired signals can occur in the nonlinear elements of the receiver, producing a third signal in the band of the desired signal. The receiver's protection against spurious response interference is a measure of the receiver's ability to discriminate between the input signal at the assigned frequency and an undesired signal at any other frequency to which it is responsive.

The 2nd- and 3rd-order intercept points of a receiver represent the two most important linearity specifications of a certain radio circuit or system. They allow us to predict the receiver's intermodulation (IM) performance, which describes the radio's susceptibility to interference for adjacent or nearby users. In this article, a modification of the traditional receiver intercept point (IP) cascading equation is presented for both the 2nd- and 3rd-order IM cases. The mathematical derivation for each of the 2nd-order (IP2) and 3rd-order (IP3) intercept point cascading equations incorporates the effect of adding selectivity (S) between receiver stages in order to improve the overall 2nd- and 3rd-order input intercept points IIP2 and IIP3, respectively.

Note: In this article, all variables in uppercase letters refer to dB or dBm units and all variables in lowercase letters refer to linear units.

In wireless specifications related to the recommended minimum performance standards for the mobile station, the receiver's intermodulation (IM) performance is specified technically under two main topics: the receiver's intermodulation spurious response attenuation and the receiver's protection against spurious response interference. The receiver's intermodulation spurious response attenuation is a measure of the receiver's ability to receive a modulated input RF signal frequency on its assigned channel frequency in the presence of two interfering CW tones. These tones are separated from the assigned input signal frequency such that the n th-order mixing of the two undesired signals can occur in the nonlinear elements of the receiver, producing a third signal in the band of the desired signal. The receiver's protection against spurious response interference is a measure of the receiver's ability to discriminate between the input signal at the assigned frequency and an undesired signal at any other frequency to which it is responsive.

Interference Due to 3rd-Order IM Products

As a result of 3rd-order mixing in a receiver front end, two off-channel CW tones at frequencies f_1 and f_2 introduce a 3rd-order intermodulation product at a frequency equal to $(2f_1 - f_2)$, which can fall in the on-channel signal passband (**Figure 1a**). This in-band 3rd-order intermodulation (IM3) product reduces the carrier-to-interference ratio (C/I) at the receiver's demodulator. Based on a linear 3:1 slope (**Figure 1b**), the level of this input IM3 product (IIM3, in dBm) can be determined using an equation that includes the receiver overall input IP3 (IIP3, in dBm) and the input power level of each of the two off-channel CW tones (P_1 , in dBm) [1]:

$$\text{IIM3} = 3 \cdot P_1 - 2 \cdot \text{IIP3}; (\text{dBm}) \quad (1)$$

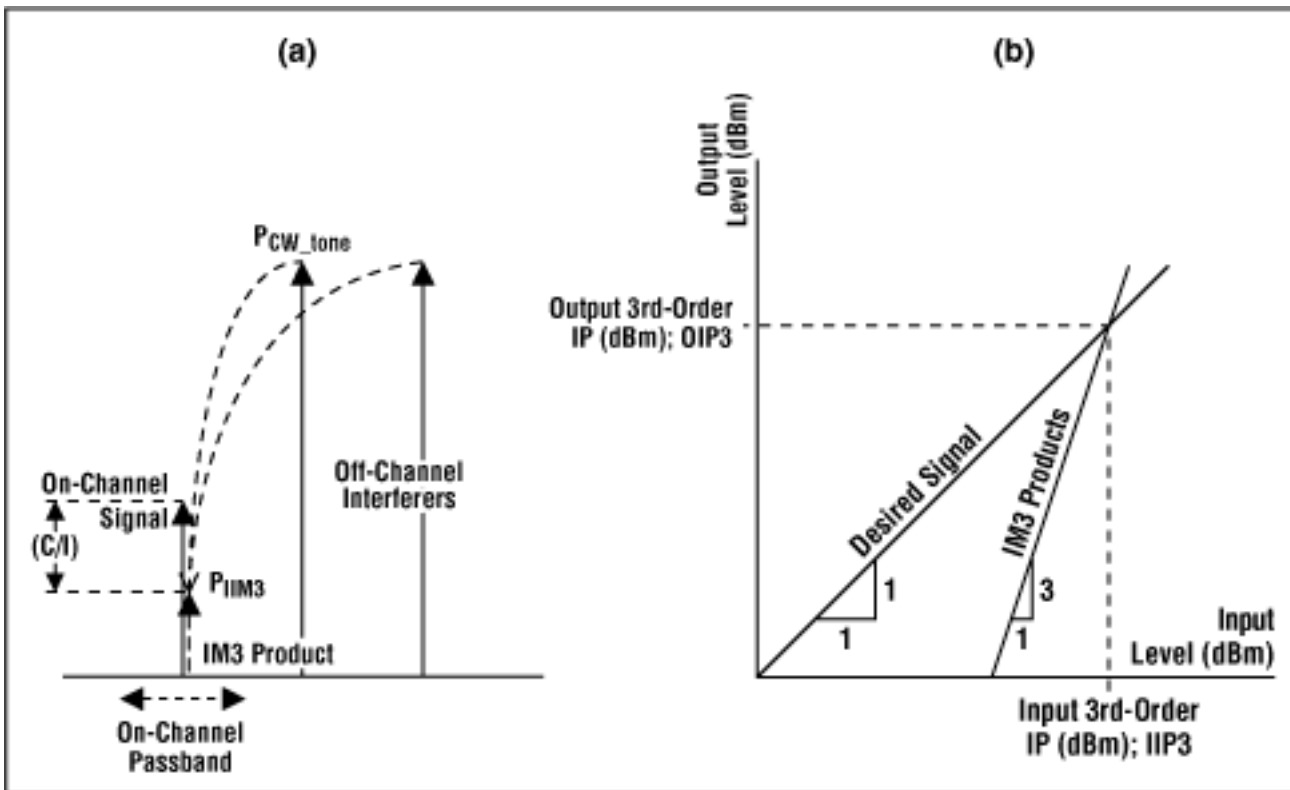

Figure 1. IM3 product as an in-band interferer due to two off-channel CW tones (a) and 3rd-order intercept point (IP) definition (b).

Figure 2 represents conventional dual-conversion superheterodyne receiver architecture. In this type of receiver architecture, the IM3 products due to the off-channel CW interferers are generated in the low-noise amplifier (LNA), the first mixer, the IF amplifier, the second mixer, and the IF limiting amplifier. All the IM3 products add up at the demodulator input, resulting in an equivalent in-band IM3 product at the receiver input (IIM3). This IM3 product, acting as an in-band interferer, can be reduced by minimizing the 3rd-order IM contribution from the IF amplifier, the second mixer, and the IF limiting amplifier. This is done by introducing a certain amount of IF selectivity (S) to these off-channel interferers in the IF filter following the first mixer (IF filter #1). Note that filter selectivity (S) refers to the attenuation in the IF filter #1 rejection band at the off-channel interferers' frequencies relative to the on-channel filter passband insertion loss (IL). Thus, the total rejection (R) (in dB) in the IF filter stopband at the off-channel CW tones' frequencies can be defined as $R = -(IL + S)$. The IF filter selectivity (S) reduces the 3rd-order distortion and dynamic range requirements of the subsequent receiver blocks. As a result, the overall receiver's IIP3 can be optimized in order to minimize the equivalent in-band IIM3 product and thus meet the required receiver baseband (C/I) ratio.

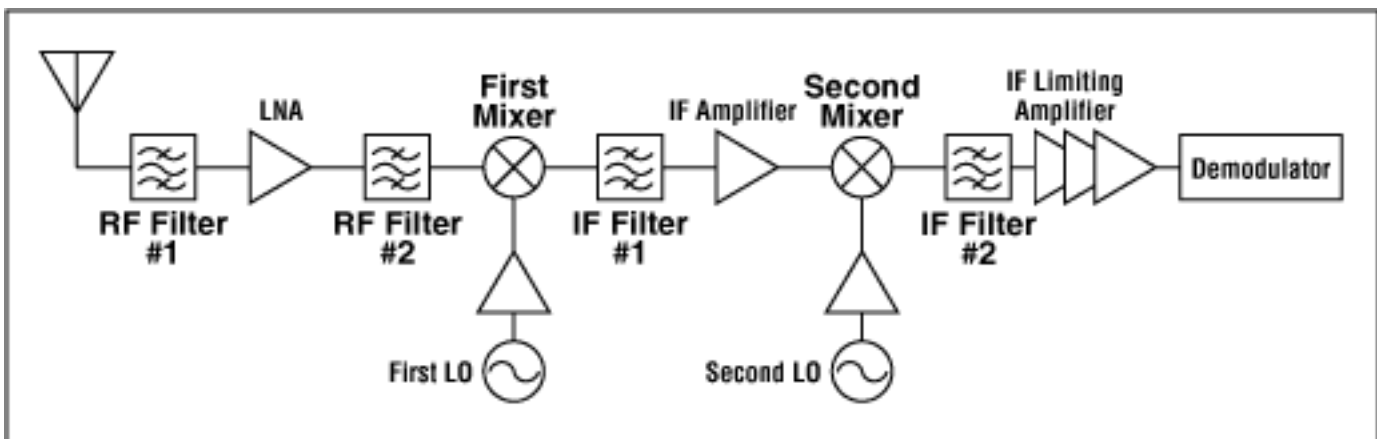

Figure 2. Conventional superheterodyne dual-conversion receiver.

Modified 3rd-Order Input Intercept Point (IIP3) Cascading Equation

In **Figure 3**, the dual-conversion receiver architecture, shown in Figure 2, is divided into three blocks: the RF block, the IF filter #1, and the IF block. The RF block, or block #1, consists of the receiver RF stages preceding the first IF filter. The IF block, or block #2, consists of the receiver's IF stages following the first IF filter. Block #1 has a gain G_1 at RF and an equivalent 3rd-order input intercept point $IIP3_1$. Block #2 has a gain G_2 at IF and an equivalent 3rd-order input intercept point $IIP3_2$. The power level of each of the two off-channel CW interferers present at the receiver input is assumed to be equal to P_1 . P_1 is the level of the two off-channel CW tones' input to block #1. P_2 is the level of the two off-channel CW tones translated to IF and input to block #2. $IIM3$ is the total IM3 distortion power due to the two off-channel CW tones, referred to the receiver input. $IIM3_1$ is the total IM3 distortion power generated in block #1, referred to its input. $IIM3_2$ is the total IM3 distortion power generated in block #2, referred to its input.

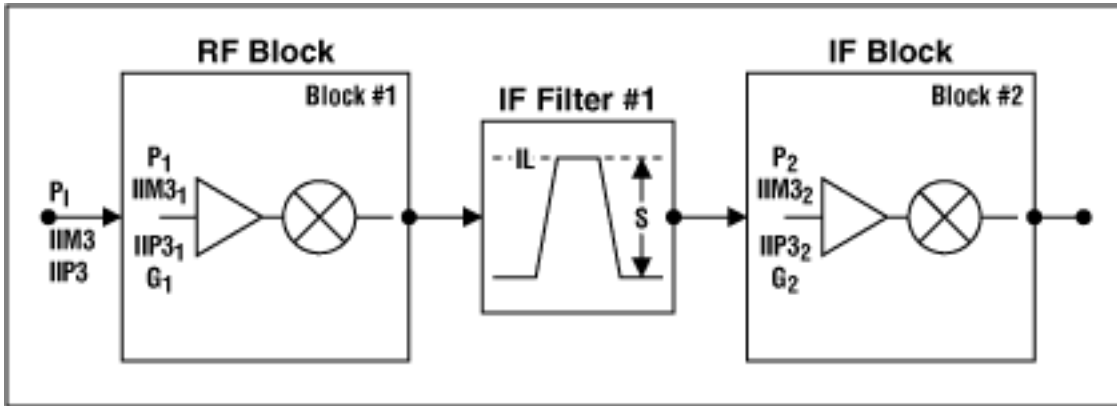

Figure 3. Block diagram for deriving the modified IP3 cascading equation, which incorporates the effect of adding selectivity (S) to receiver stages at the two off-channel CW tones' frequencies. Power symbols in dBm, and gain in dB.

In the following derivation, the input $IIM3$ distortion voltage of block #1 and the input $IIM3$ distortion voltage of block #2, divided by the voltage gain of preceding stages, are added exactly in-phase as a worst-case condition to get the total $IIM3$ distortion voltage, referred to the receiver input. Assuming a system characteristic impedance of 1Ω , we can write the following:

$$\sqrt{iim3} = \sqrt{iim3_1} + \sqrt{\frac{iim3_2}{g_1/il}}; \text{ volts} \quad (2)$$

where the square root converts the $IIM3$ powers to voltages. The terms $iim3$, $iim3_1$, and $iim3_2$ are in linear power units (watts or milliwatts). Also, G_1 (dB) = $10 \cdot \log_{10}(g_1)$ and IL (dB) = $10 \cdot \log_{10}(il)$.

Equation (1) can be rearranged into the following equation:

$$IIP3 = P_I + \frac{1}{2} \cdot (P_I - IIM3); \text{ (dBm)} \quad (3)$$

Equation (3) defines the input $IP3$ for the whole receiver. Equation (3) can be rewritten in linear power units (milliwatts, or mW), instead of dBm:

$$\frac{P_I}{iip3} = \sqrt{\frac{iim3}{P_I}}; \quad (4)$$

Similar to what we did in equation (3), we can define IIP3₁ and IIP3₂ for block #1 and block #2, respectively, as:

$$IIP3_1 = P_1 + \frac{1}{2} * (P_1 - IIM3_1); \text{ (dBm)} \quad (5)$$

$$IIP3_2 = P_2 + \frac{1}{2} * (P_2 - IIM3_2); \text{ (dBm)} \quad (6)$$

Knowing that P₁(dBm) = P₁ and P₂(dBm) = P₁ + (G₁ - IL - S), we obtain from equations (5) and (6):

$$IIP3_1 = P_1 + \frac{1}{2} * (P_1 - IIM3_1); \text{ (dBm)} \quad (7)$$

$$IIP3_2 = (P_1 + G_1 - IL - S) + \frac{1}{2} * (P_1 + G_1 - IL - S - IIM3_2); \text{ (dBm)} \quad (8)$$

As we have done for equation (3), equations (7) and (8) can be rewritten in linear power units, instead of dBm, to result in equations (9) and (10), respectively:

$$\frac{P_I}{iip3_1} = \sqrt{\frac{iim3_1}{P_I}}; \quad (9)$$

$$\frac{P_I * (g_1/il)}{iip3_2 * s^{3/2}} = \sqrt{\frac{iim3_2}{(g_1/il) * P_I}}; \quad (10)$$

where S(dB) = 10.log₁₀(s) and IL(dB) = 10.log₁₀(il). Note that S(dB) and IL(dB) are positive numbers.

Going back to equation (2) and dividing it by (p₁)^{1/2},

$$\sqrt{\frac{iim3}{P_I}} = \sqrt{\frac{iim3_1}{P_I}} + \sqrt{\frac{iim3_2}{(g_1/il) * P_I}}; \quad (11)$$

If we substitute each term in equation (11) by equivalent terms using equations (4), (9), and (10), and after simplifying by removing the term p₁, we obtain the following modified IIP3 cascading equation:

$$\frac{1}{iip3} = \frac{1}{iip3_1} + \frac{(g_1/il)}{iip3_2 * s^{3/2}}; \quad (12)$$

As we can see from equation (12), by choosing a highly selective IF filter ($s \gg 1$), we can minimize the effect of the IF block input IP3 ($IIP3_2$) on the overall receiver input IP3 ($IIP3$), which becomes almost defined by the RF block IIP3 ($IIP3_1$). It is worth noting that, in a cascaded system analysis, the IF block input IP3 ($IIP3_2$) should be replaced with an equivalent input IP3, which incorporates the effect of introducing selectivity ahead of the IF block. This equivalent $IIP3_2$ can be written as:

$$IIP3_2^e = IIP3_2 + (3/2) \cdot S; (\text{dBm}) \quad (13)$$

A more generalized equation predicting the overall input IP3 of a receiver chain with M cascaded stages can be formulized based on equation (12). Each stage has a linear gain (g_n), an input IP3 ($iip3_n$, in watts), and a selectivity (s_n) at the two off-channel CW tones' frequencies, which introduce an in-band IM3 product:

$$\frac{1}{iip3} = \frac{1}{iip3_1} + \frac{g_1}{iip3_2 \cdot s_1^{3/2}} + \frac{g_1 \cdot g_2}{iip3_3 \cdot (s_1 \cdot s_2)^{3/2}} + \dots + \frac{g_1 \cdot g_2 \cdot \dots \cdot g_{M-1}}{iip3_M \cdot (s_1 \cdot s_2 \cdot \dots \cdot s_{M-1})^{3/2}}; \quad (14)$$

where $S_n(\text{dB}) = 10 \cdot \log_{10}(s_n)$. Note: This equation simplifies to the classic equation for intercept point calculation of a cascade of M stages when setting s_n to 1, which translates into setting selectivity S_n to 0dB [1].

Interference Due to 2nd-Order IM Products

Receiver spurious responses are frequencies that are different from the on-channel RF signal frequency, yet that still produce an output interferer in the receiver passband if encountered at a sufficiently high level. One of these spurious response frequencies is at the half-IF frequency. This half-IF spurious response results in a 2nd-order intermodulation product (IM2), which occurs in the receiver RF front end. Its level can be predicted from the 2nd-order intercept point (IP2) of the receiver RF front end, which is defined up to and including the first mixer in the receiver chain (Figure 2). For high-side injection in the first mixer (**Figure 4a**), a CW tone at the input of the receiver, which is offset from the LO frequency by $-f_{IF}/2$, is downconverted to IF by the $(-2 \cdot f_{CW} + 2 \cdot f_{LO})$ IM product, occurring in the first mixer [1,2]. As for low-side injection, a CW tone, which is offset from the LO frequency by $+f_{IF}/2$, is downconverted to IF by the $(2 \cdot f_{CW} - 2 \cdot f_{LO})$ IM product. Based on a linear 2:1 slope (**Figure 4b**), the level of this input IM2 product (IIM2, in dBm) can be determined using an equation that includes the receiver RF front-end input IP2 (IIP2, in dBm) and the power level of the input half-IF CW tone (P_I , in dBm) [1]:

$$IIM2 = 2 \cdot P_I - IIP2; (\text{dBm}) \quad (15)$$

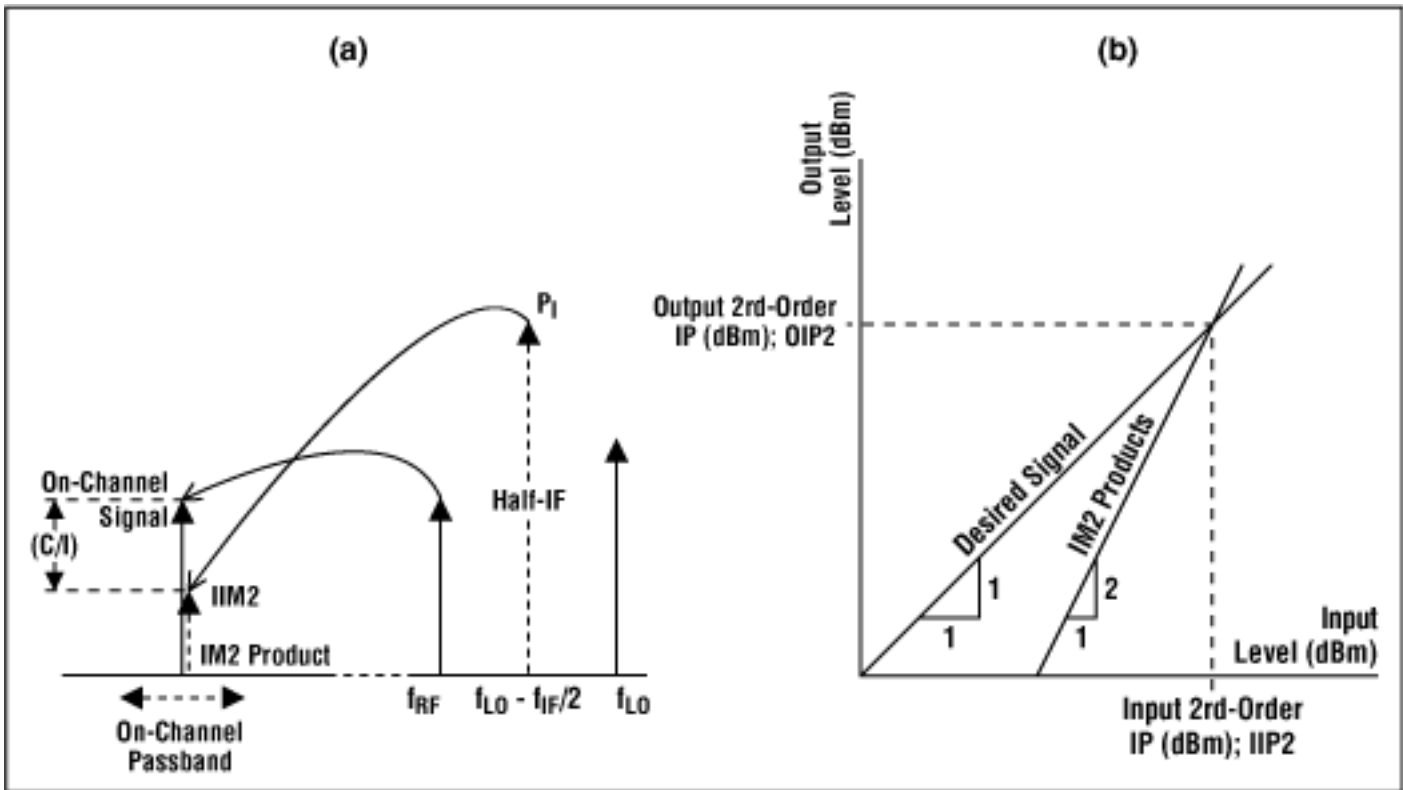

Figure 4. IM2 product as an in-band interferer due to half-IF spurious response (a) and 2nd-order intercept point (IP) definition (b).

This in-band IM2 product due to the half-IF spurious response can be reduced by minimizing the 2nd-order IM contribution from the first mixer. This is done by introducing a certain amount of RF selectivity (S) to this off-channel interferer in the RF filters preceding the first mixer (RF filters #1 and #2). Note that filter selectivity (S) refers to the attenuation in the RF filter rejection band at the spurious response frequency relative to the on-channel filter passband insertion loss (IL). The RF filter selectivity (S) reduces the 2nd-order distortion and dynamic range requirements of the first mixer. As a result, the overall receiver's RF front-end IIP2 can be optimized in order to minimize the equivalent in-band IIM2 product due to the half-IF tone, thus meeting the required receiver baseband (C/I) ratio.

Modified 2nd-Order Input Intercept Point (IIP2) Cascading Equation

In **Figure 5**, the dual-conversion receiver RF front end is divided into three blocks: RF filter #2, block #1 (which consists of all stages preceding RF filter #2), and block #2 (which follows RF filter #2 and includes the first mixer). Block #1 has a gain G_1 at RF and an equivalent 2nd-order input intercept point $IIP2_1$. Block #2 has a gain G_2 at RF and an equivalent 2nd-order input intercept point $IIP2_2$. The power level of each half-IF CW tone present at the receiver input is assumed to be equal to P_1 . P_1 is the level of the half-IF CW tone input to block #1. P_2 is the level of the half-IF CW tone input to block #2. $IIM2$ is the total IM2 distortion power due to the half-IF CW tone, referred to the receiver input. $IIM2_1$ is the total IM2 distortion power generated in block #1, referred to its input. $IIM2_2$ is the total IM2 distortion power generated in block #2, referred to its input.

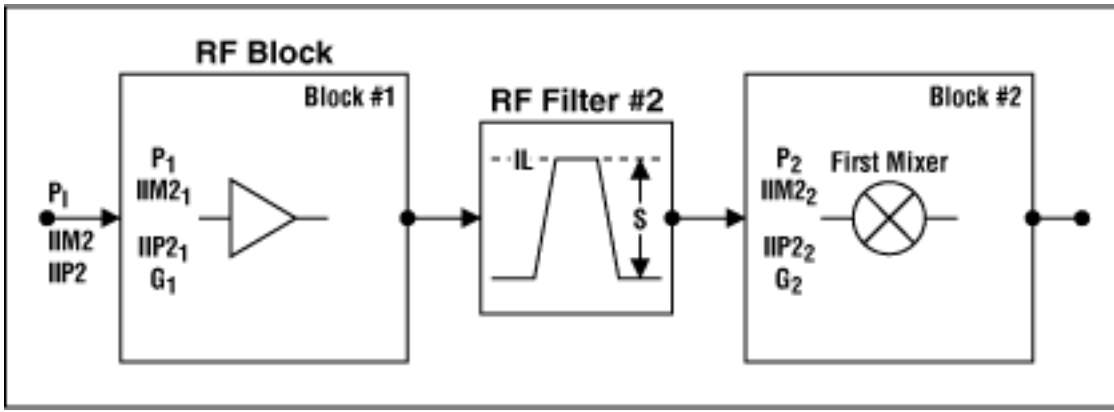

Figure 5. Block diagram for deriving the modified IP2 cascading equation, which incorporates the effect of adding RF selectivity (S) to receiver RF front-end stages at the half-IF spurious frequency. Power symbols in dBm, and gain in dB.

In the following derivation, the input IM2 distortion voltage of block #1 and the input IM2 distortion voltage of block #2, divided by the voltage gain of preceding stages, are added exactly in-phase as a worst-case condition to get the total IM2 distortion voltage, referred to the receiver input. Assuming a system characteristic impedance of 1Ω , we can write the following:

$$\sqrt{iim2} = \sqrt{iim2_1} + \sqrt{\frac{iim2_2}{g_1/il}}; \text{ volts} \quad (16)$$

where the square root converts the IIM2 powers to voltages. The terms $iim2$, $iim2_1$, and $iim2_2$ are in linear power units (watts or milliwatts). Also, G_1 (dB) = $10 \cdot \log_{10}(g_1)$ and IL (dB) = $10 \cdot \log_{10}(il)$.

Equation (15) can be rearranged into the following equation:

$$IIP2 = P_1 + (P_1 - IIM2); \text{ (dBm)} \quad (17)$$

Equation (17) defines the input IP2 for the whole receiver. Equation (17) can be rewritten in linear power units (milliwatts, or mW), instead of dBm:

$$\frac{P_1}{iip2} = \frac{iim2}{P_1}; \quad (18)$$

Similar to what we did with equation (17), we can define $IIP2_1$ and $IIP2_2$ for block #1 and block #2, respectively, as:

$$IIP2_1 = P_1 + (P_1 - IIM2_1); \text{ (dBm)} \quad (19)$$

$$IIP2_2 = P_2 + (P_2 - IIM2_2); \text{ (dBm)} \quad (20)$$

Knowing that P_1 (dBm) = P_1 and P_2 (dBm) = $P_1 + (G_1 - IL - S)$, we obtain from equations (19) and (20):

$$IIP2_1 = P_1 + (P_1 - IIM2_1); \text{ (dBm)} \quad (21)$$

$$IIP2_2 = (P_1 + G_1 - IL - S) + (P_1 + G_1 - IL - S - IIM2_2); \text{ (dBm)} \quad (22)$$

As we have done for equation (17), equations (21) and (22) can be rewritten in linear power units, instead of dBm, to result in equations (23) and (24), respectively:

$$\frac{P_1}{iip2_1} = \frac{iim2_1}{P_1}; \quad (23)$$

$$\frac{P_1 \cdot (g_1/il)}{iip2_2 \cdot s^2} = \frac{iim2_2}{(g_1/il) \cdot P_1}; \quad (24)$$

where $S(\text{dB}) = 10 \cdot \log_{10}(s)$ and $IL(\text{dB}) = 10 \cdot \log_{10}(il)$. Note that $S(\text{dB})$ and $IL(\text{dB})$ are positive numbers.

Returning to equation (16) and dividing it by $(p_1)^{1/2}$,

$$\sqrt{\frac{iim2}{P_1}} = \sqrt{\frac{iim2_1}{P_1}} + \sqrt{\frac{iim2_2}{(g_1/il) \cdot P_1}}; \quad (25)$$

If we substitute each term in equation (25) by equivalent terms using equations (18), (23), and (24), and after simplifying by removing the term p_1 , we obtain the following modified IIP2 cascading equation:

$$\sqrt{\frac{1}{iip2}} = \sqrt{\frac{1}{iip2_1}} + \sqrt{\frac{(g_1/il)}{iip2_2 \cdot s^2}}; \quad (26)$$

As we can see from equation (12), by choosing a highly selective RF filter ($s \gg 1$), we can minimize the effect of the first-mixer block input IP2 ($IIP2_2$) on the overall receiver RF front-end input IP2 ($IIP2$). It is worth noting that, in a cascaded system analysis, the first-mixer block input IP2 ($IIP2_2$) should be replaced with an equivalent input IP2, which incorporates the effect of introducing selectivity in the RF filter. This equivalent $IIP2_2$ can be written as:

$$IIP2_2^{\text{e}} = IIP2_2 + 2 \cdot S; \text{ (dBm)} \quad (27)$$

A more generalized equation to predict the overall input IP2 of a receiver's RF front-end chain with M cascaded stages can be formulized based on equation (26). Each stage has a linear gain (g_n), an input IP2 ($iip2_n$, in watts), and a selectivity (s_n) at the half-IF CW tone frequency, which introduces an in-band IM2 product:

$$\sqrt{\frac{1}{iip2}} = \sqrt{\frac{1}{iip2_1}} + \sqrt{\frac{g_1}{iip2_2 \cdot s_1^2}} + \sqrt{\frac{g_1 \cdot g_2}{iip2_3 \cdot (s_1 \cdot s_2)^2}} + \dots + \sqrt{\frac{g_1 \cdot g_2 \cdot \dots \cdot g_{M-1}}{iip2_M \cdot (s_1 \cdot s_2 \cdot \dots \cdot s_{M-1})^2}}; \quad (28)$$

where $S_n(\text{dB}) = 10 \cdot \log_{10}(s_n)$.

References

1. S. Maas, *Microwave Mixers*, Norwood, MA; Artech House, 1993.
2. P. Vizmuller, *RF Design Guide*, Norwood, MA; Artech House, 1995.

A similar version of this article appeared in the December 1997 issue of *RF Design*.

Application Note 749: <http://www.maxim-ic.com/an749>

More Information

For technical questions and support: <http://www.maxim-ic.com/support>

For samples: <http://www.maxim-ic.com/samples>

Other questions and comments: <http://www.maxim-ic.com/contact>

Related Parts

MAX1470: [QuickView](#) -- [Full \(PDF\) Data Sheet](#)

MAX2116: [QuickView](#) -- [Full \(PDF\) Data Sheet](#)

MAX2320: [QuickView](#) -- [Full \(PDF\) Data Sheet](#)

MAX2338: [QuickView](#) -- [Full \(PDF\) Data Sheet](#)

MAX2410: [QuickView](#) -- [Full \(PDF\) Data Sheet](#)

MAX2420: [QuickView](#) -- [Full \(PDF\) Data Sheet](#) -- [Free Samples](#)

MAX2538: [QuickView](#) -- [Full \(PDF\) Data Sheet](#)

MAX2700: [QuickView](#) -- [Full \(PDF\) Data Sheet](#) -- [Free Samples](#)

MAX2820: [QuickView](#) -- [Full \(PDF\) Data Sheet](#)

AN749, AN 749, APP749, Appnote749, Appnote 749

Copyright © by Maxim Integrated Products

Additional legal notices: <http://www.maxim-ic.com/legal>