



APPLICATION NOTE 686

QPSK Modulation Demystified

Abstract: Readers are presented with step by step derivations showing the operation of [QPSK](#) modulation and demodulation. The move from analog communication to digital has advanced the use of QPSK. Euler's relation is used to assist analysis of multiplication of sine and cosine signals. A SPICE simulation is used to illustrate QPSK modulation of a 1MHz sine wave. A phasor diagram shows the impact of poor synchronization with the local oscillator. Digital processing is used to remove phase and frequency errors.

Since the early days of electronics, as advances in technology were taking place, the boundaries of both local and global communication began eroding, resulting in a world that is smaller and hence more easily accessible for the sharing of knowledge and information. The pioneering work by Bell and Marconi formed the cornerstone of the information age that exists today and paved the way for the future of telecommunications.

Traditionally, local communication was done over wires, as this presented a cost-effective way of ensuring a reliable transfer of information. For long-distance communications, transmission of information over radio waves was needed. Although this was convenient from a hardware standpoint, radio-waves transmission raised doubts over the corruption of the information and was often dependent on high-power transmitters to overcome weather conditions, large buildings, and interference from other sources of electromagnetics.

The various modulation techniques offered different solutions in terms of cost-effectiveness and quality of received signals but until recently were still largely analog. Frequency modulation and phase modulation presented a certain immunity to noise, whereas amplitude modulation was simpler to demodulate. However, more recently with the advent of low-cost microcontrollers and the introduction of domestic mobile telephones and satellite communications, digital modulation has gained in popularity. With digital modulation techniques come all the advantages that traditional microprocessor circuits have over their analog counterparts. Any shortfalls in the communications link can be eradicated using software. Information can now be encrypted, error correction can ensure more confidence in received data, and the use of DSP can reduce the limited bandwidth allocated to each service.

As with traditional analog systems, digital modulation can use amplitude, frequency, or phase modulation with different advantages. As frequency and phase modulation techniques offer more immunity to noise, they are the preferred scheme for the majority of services in use today and will be discussed in detail below.

Digital Frequency Modulation

A simple variation from traditional analog frequency modulation ([FM](#)) can be implemented by applying a digital signal to the modulation input. Thus, the output takes the form of a sine wave at two distinct frequencies. To demodulate this waveform, it is a simple matter of passing the signal through two filters and translating the resultant back into logic levels. Traditionally, this form of modulation has been called frequency-shift keying (FSK).

Digital Phase Modulation

Spectrally, digital phase modulation, or phase-shift keying ([PSK](#)), is very similar to frequency modulation. It involves changing the phase of the transmitted waveform instead of the frequency, these finite phase changes representing digital data. In its simplest form, a phase-modulated waveform can be generated by using the digital data to switch between two signals of equal frequency but opposing phase. If the resultant waveform is multiplied by a sine wave of equal frequency, two components are generated: one cosine waveform of double

the received frequency and one frequency-independent term whose amplitude is proportional to the cosine of the phase shift. Thus, filtering out the higher-frequency term yields the original modulating data prior to transmission. This is difficult to picture conceptually, but mathematical proof will be shown later.

Quadrature-Phase-Shift Modulation

Taking the above concept of PSK a stage further, it can be assumed that the number of phase shifts is not limited to only two states. The transmitted "carrier" can undergo any number of phase changes and, by multiplying the received signal by a sine wave of equal frequency, will demodulate the phase shifts into frequency-independent voltage levels.

This is indeed the case in quadrature-phase-shift keying (QPSK). With QPSK, the carrier undergoes four changes in phase (four symbols) and can thus represent 2 binary bits of data per symbol. Although this may seem insignificant initially, a modulation scheme has now been supposed that enables a carrier to transmit 2 bits of information instead of 1, thus effectively doubling the bandwidth of the carrier.

The proof of how phase modulation, and hence QPSK, is demodulated is shown below.

The proof begins by defining Euler's relations, from which all the trigonometric identities can be derived.

Euler's relations state the following:

$$\sin \omega t = \frac{e^{j\omega t} - e^{-j\omega t}}{2j} \quad \cos \omega t = \frac{e^{j\omega t} + e^{-j\omega t}}{2}$$

Now consider multiplying two sine waves together, thus

$$\begin{aligned} \sin^2 \omega t &= \frac{e^{j\omega t} - e^{-j\omega t}}{2j} \times \frac{e^{j\omega t} - e^{-j\omega t}}{2j} = \frac{e^{2j\omega t} - 2e^0 + e^{-2j\omega t}}{-4} \\ &= \frac{1}{2} - \frac{1}{2} \cos 2\omega t \quad \text{Equation 1} \end{aligned}$$

From Equation 1, it can be seen that multiplying two sine waves together (one sine being the incoming signal, the other being the local oscillator at the receiver mixer) results in an output frequency $\left(\frac{1}{2} \cos 2\omega t\right)$ double that of the input (at half the amplitude) superimposed on a dc offset of half the input amplitude.

Similarly, multiplying $\sin \omega t$ by $\cos \omega t$ gives

$$\begin{aligned} \sin \omega t \times \cos \omega t &= \frac{e^{2j\omega t} - e^{-2j\omega t}}{4j} \\ &= \frac{1}{2} \sin 2\omega t \end{aligned}$$

which gives an output frequency ($\sin 2\omega t$) double that of the input, with no dc offset.

It is now fair to make the assumption that multiplying $\sin \omega t$ by any phase-shifted sine wave ($\sin \omega t + \phi$) yields a "demodulated" waveform with an output frequency double that of the input frequency, whose dc offset varies according to the phase shift, ϕ .

To prove this,

$$\begin{aligned} \sin \omega t \times \sin(\omega t + \phi) &= \frac{e^{j\omega t} - e^{-j\omega t}}{2j} \times \frac{e^{j(\omega t + \phi)} - e^{-j(\omega t + \phi)}}{2j} \\ &= \frac{e^{j(2\omega t + \phi)} - e^{j(\omega t - \omega t - \phi)} - e^{j(\omega t + \phi - \omega t)} + e^{-j(2\omega t + \phi)}}{-4} \\ &= \frac{\cos(2\omega t + \phi)}{-2} - \frac{e^{j\phi} + e^{-j\phi}}{-4} \\ &= \frac{\cos(2\omega t + \phi)}{-2} + \frac{\cos \phi}{2} \\ &= \frac{\cos \phi}{2} - \frac{\cos(2\omega t + \phi)}{2} \end{aligned}$$

Thus, the above proves the supposition that the phase shift on a carrier can be demodulated into a varying output voltage by multiplying the carrier with a sine-wave local oscillator and filtering out the high-frequency term. Unfortunately, the phase shift is limited to two quadrants; a phase shift of $\pi/2$ cannot be distinguished from a phase shift of $-\pi/2$. Therefore, to accurately decode phase shifts present in all four quadrants, the input signal needs to be multiplied by both sinusoidal and cosinusoidal waveforms, the high frequency filtered out, and the data reconstructed. The proof of this, expanding on the above mathematics, is shown below.

Thus,

$$\begin{aligned} \cos \omega t \times \sin(\omega t + \phi) &= \frac{e^{j\omega t} + e^{-j\omega t}}{2} \times \frac{e^{j(\omega t + \phi)} - e^{-j(\omega t + \phi)}}{2j} \\ &= \frac{e^{j(2\omega t + \phi)} - e^{j(-\phi)} + e^{j(\phi)} - e^{-j(2\omega t + \phi)}}{4j} \\ &= \frac{\sin(2\omega t + \phi)}{2} + \frac{e^{j\phi} - e^{-j\phi}}{4j} \\ &= \frac{\sin(2\omega t + \phi)}{2} + \frac{\sin \phi}{2} \end{aligned}$$

A SPICE simulation verifies the above theory. **Figure 1A** shows a block diagram of a simple demodulator circuit. The input voltage, QSPK IN, is a 1MHz sine wave whose phase is shifted by 45°, 135°, 225°, and then 315° every 5μs.

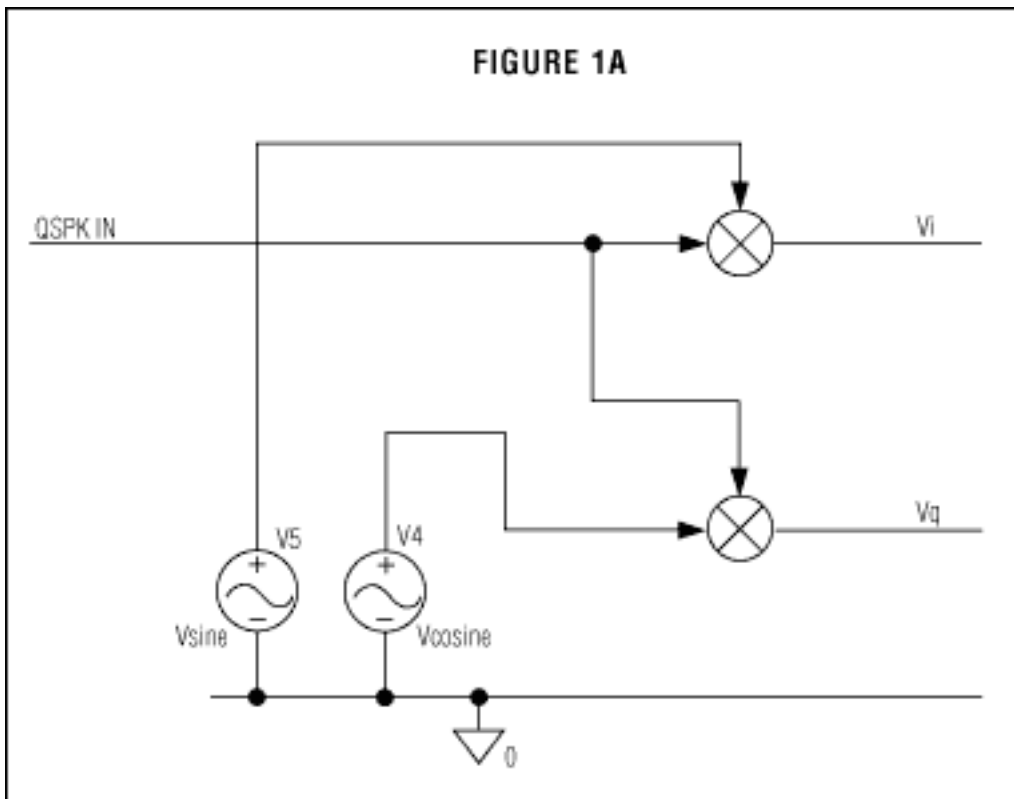

Figures 2 and 3 show the "in-phase" waveform, V_i , and the "quadrature" waveform, V_q , respectively. Both have a frequency of 2MHz with a dc offset proportional to the phase shift, confirming the above mathematics.

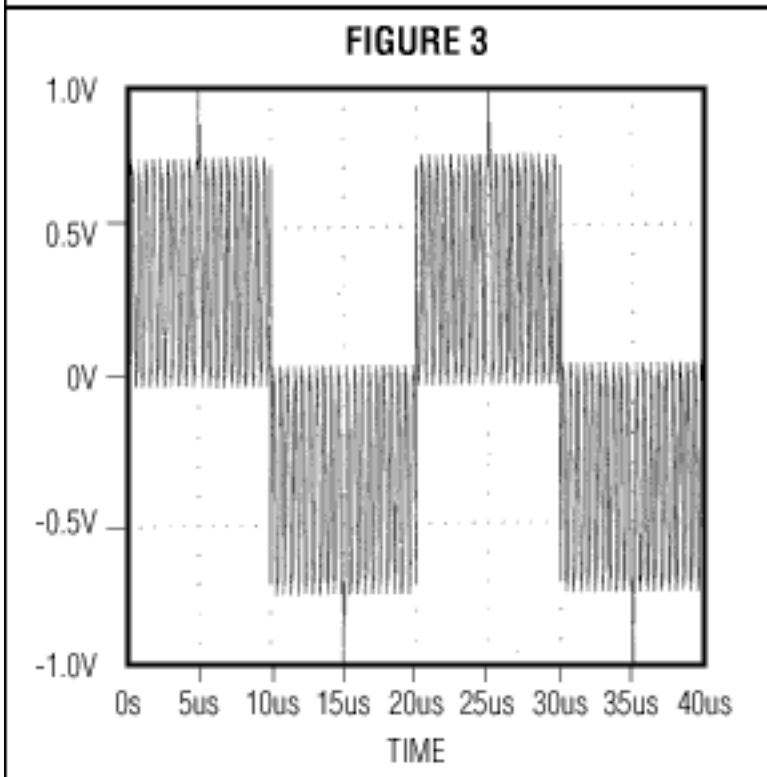
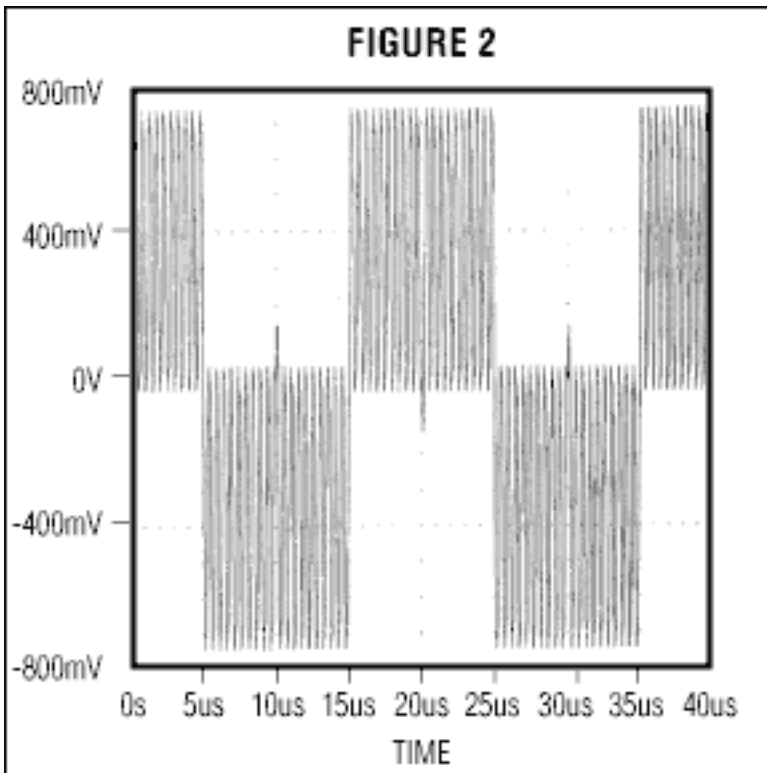
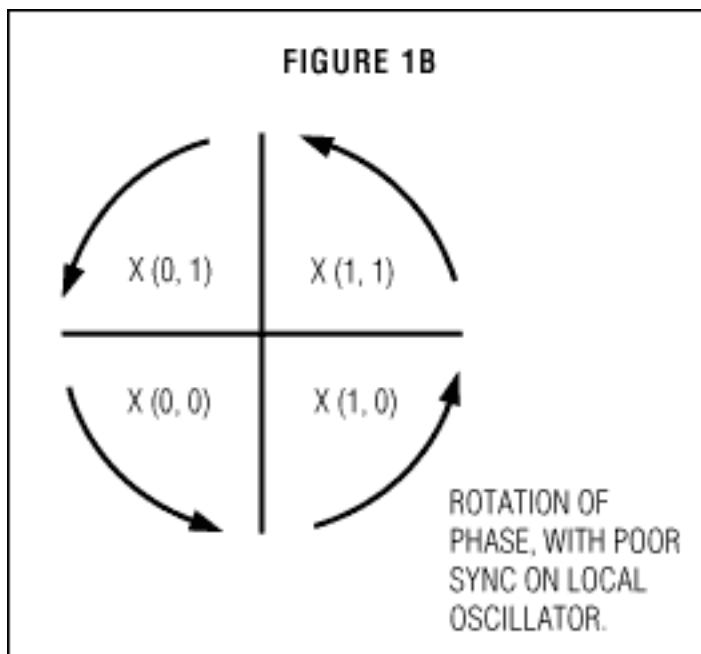

Figure 1B is the phasor diagram showing the phase shift of QPSK IN and the demodulated data.



The above theory is perfectly acceptable, and it would appear that removing the data from the carrier is a simple process of low-pass filtering the output of the mixer and reconstructing the 4 voltages back into logic levels. In practice, getting a receiver local oscillator exactly synchronized with the incoming signal is not easy. If the local oscillator varies in phase with the incoming signal, the signals on the phasor diagram will undergo a phase rotation, its magnitude equal to the phase difference. Moreover, if the phase *and* frequency of the local oscillator are not fixed with respect to the incoming signal, there will be a continuing rotation on the phasor diagram.

Therefore, the output of the front-end demodulator is normally fed into an ADC and any rotation resulting from errors in the phase or frequency of the local oscillator are removed in DSP.

An effective way of converting straight to baseband is using a direct-conversion tuner IC.

The above devices are part of the rapidly expanding RF chipsets from Maxim Integrated Products. With five high-speed processes, more than 70 high-frequency standard products, and 52 ASICs in development, Maxim is committed to being a major player in the RF/wireless, fiber/cable, and instrumentation markets.

Application Note 686: www.maxim-ic.com/an686

More Information

For technical support: www.maxim-ic.com/support

For samples: www.maxim-ic.com/samples

Other questions and comments: www.maxim-ic.com/contact

Automatic Updates

Would you like to be automatically notified when new application notes are published in your areas of interest?
[Sign up for EE-Mail.](#)

Related Parts

MAX1002: [QuickView](#) -- [Full \(PDF\) Data Sheet](#) -- [Free Samples](#)

MAX1003: [QuickView](#) -- [Full \(PDF\) Data Sheet](#) -- [Free Samples](#)

MAX2361: [QuickView](#) -- [Full \(PDF\) Data Sheet](#) -- [Free Samples](#)

MAX2411A: [QuickView](#) -- [Full \(PDF\) Data Sheet](#) -- [Free Samples](#)

AN686, AN 686, APP686, Appnote686, Appnote 686
Copyright © by Maxim Integrated Products
Additional legal notices: www.maxim-ic.com/legal