

APPLICATION NOTE 673

## 5-to-1.8V Converter Works Without Magnetics

*Abstract: To derive 1.8V from 5V, you might think of using a switch-mode regulator. Switchers are highly efficient but require inductors. Linear regulators are simple, but would have only 40% efficiency. This circuit is more than 70% efficient (Figure 2a), sources as much as 100 mA, and uses no inductor.*

To derive 1.8V from 5V, you might think of using a switch-mode regulator. Switchers are highly efficient but also complicated and expensive. Linear regulators, too, are out of the question unless your design can tolerate 40% efficiencies. The circuit in **Figure 1**, on the other hand, is more than 70% efficient (**Figure 2a**), sources as much as 100 mA, costs less than a switch-mode regulator, and requires less space. IC<sub>1</sub> is a CMOS charge-pump voltage converter that the circuit configures as a voltage inverter. With its output grounded and 5V at its V<sub>+</sub> pin, IC<sub>1</sub> generates V<sub>+</sub>/2, or approximately 2.5V at Pin 3. This nominal 2.5V output, which sags as the device sources current, drives linear-regulator IC<sub>2</sub>, which regulates the 2.5V input to 1.8V. IC<sub>2</sub> is capable of sourcing 100 mA before its sagging input voltage falls below the dropout level (**Figure 2b**). Using larger values for C<sub>1</sub> and C<sub>2</sub> enables IC<sub>1</sub> to maintain its output voltage with heavier load currents. If the load current drawn from this circuit is 50mA or less, you can substitute the MAX1730 for this circuit. This regulated charge pump is designed specifically to step voltages down to a lower level. (DI #2511)

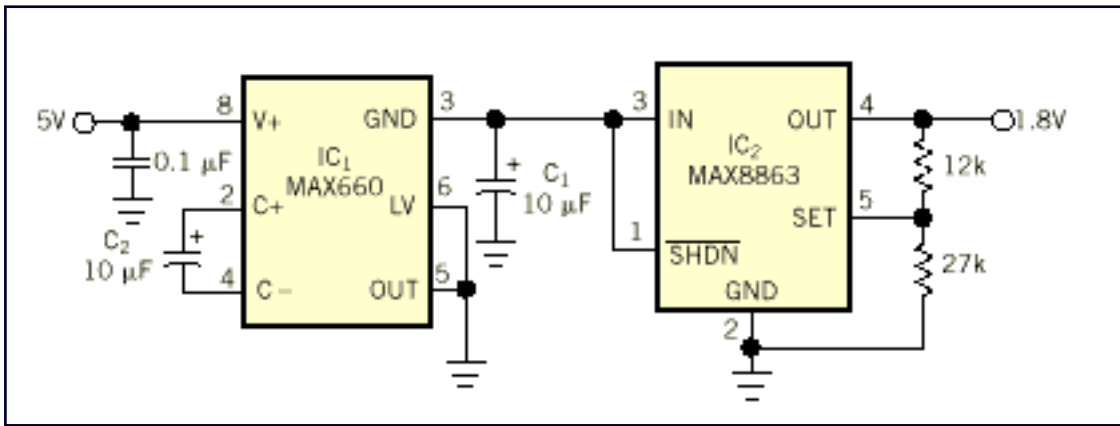

Figure 1. A 5-to-1.8V converter uses a charge-pump IC to lower the input voltage and then uses a linear regulator to achieve the desired output level.

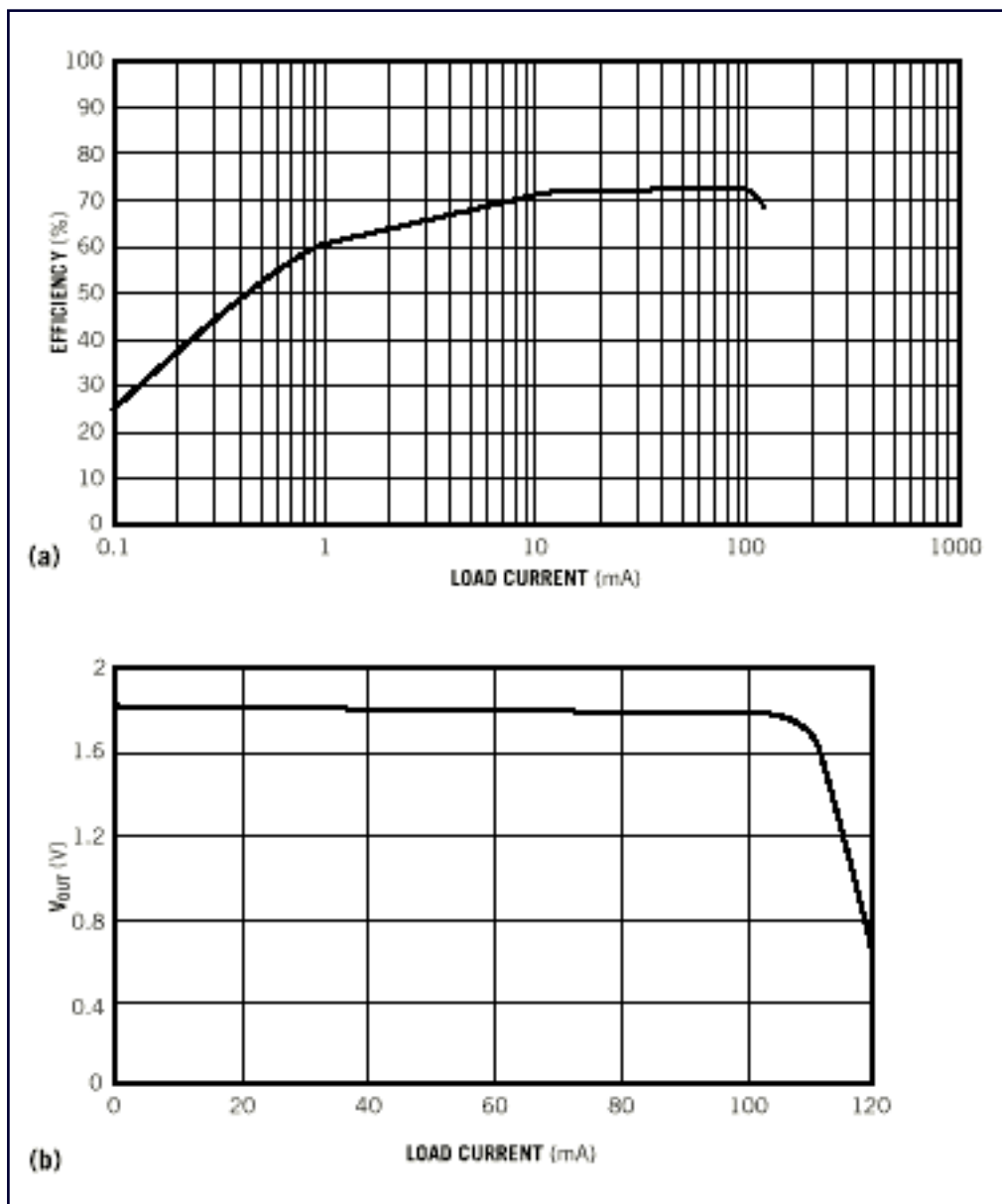

Figure 2. The circuit provides maximum efficiency for load currents of 10 to 100 mA (a) and maintains its output level for load currents as high as 100 mA (b).

Reprinted from EDN Magazine April 13, 2000  
 Copyright Cahners Business Information 2000  
 A Division of Reed Elsevier Inc.

Application Note 673: <http://www.maxim-ic.com/an673>

### More Information

For technical questions and support: <http://www.maxim-ic.com/support>

For samples: <http://www.maxim-ic.com/samples>

Other questions and comments: <http://www.maxim-ic.com/contact>

### Related Parts

MAX660: [QuickView](#) -- [Full \(PDF\) Data Sheet](#) -- [Free Samples](#)

AN673, AN 673, APP673, Appnote673, Appnote 673

Copyright © by Maxim Integrated Products

Additional legal notices: <http://www.maxim-ic.com/legal>

