

**Application Note:**

**HFAN-3.0.0**

Re.1;04/08

---

---

## **Accurately Estimating Optical Receiver Sensitivity**

---

---



*Maxim Integrated Products*

# Accurately Estimating Optical Receiver Sensitivity

## 1 Introduction

In optical communication systems, sensitivity is a measure of how weak an input signal can get before the bit-error ratio (BER) exceeds some specified number. The standards body governing the application sets this specified BER. For example, SONET specifies that the BER must be  $10^{-10}$  or better. Gigabit Ethernet and Fibre Channel specifications require a BER of  $10^{-12}$  or better. This BER is the foundation for determining a receiver's sensitivity.

In the design of an optical receiver, such as a small form factor optical transceiver module, it is vital that the module be capable of converting and shaping the optical signal while meeting or surpassing the maximum BER. Ultimately, the influence of noise on the signal will determine the sensitivity of the system. The portion of the receiver that contributes the most noise is the optical-to-electrical conversion provided by the photodetector and the transimpedance amplifier (TIA). More often than not, designers will use a combination of simple estimation and “rules of thumb” to predict performance and select components. This discussion presents a reliable method for estimating the receiver's sensitivity. (The appendix at the end of this note provides useful definitions and formulae for use in optical receiver performance specification.)

## 2 Traditional Analysis

Sensitivity can be expressed as average power ( $P_{AVG}$ ) in dBm or as optical modulation amplitude (OMA) in Wpp. Each gives a figure of merit for the receiver. The sensitivity is the minimum OMA or  $P_{AVG}$  at which the maximum (worst tolerable) BER can be maintained. Optical transmission system designers use sensitivity to determine the maximum distance or link margin available in their system. Expressing the sensitivity in terms of average power is useful, because the average power of a laser is more easily measured than peak-to-peak power. Measuring the peak-to-peak power of a laser at high data rates requires expensive equipment that is error-prone due to the amount of operator intervention. Average optical power can be measured easily and reliably with a relatively inexpensive optical power meter.

Figure 1 shows a simple block diagram of the front end of an optical receiver. The dominant noise sources in this section are the linear components that provide the optical-to-electrical conversion, namely, the photodiode and the transimpedance amplifier.

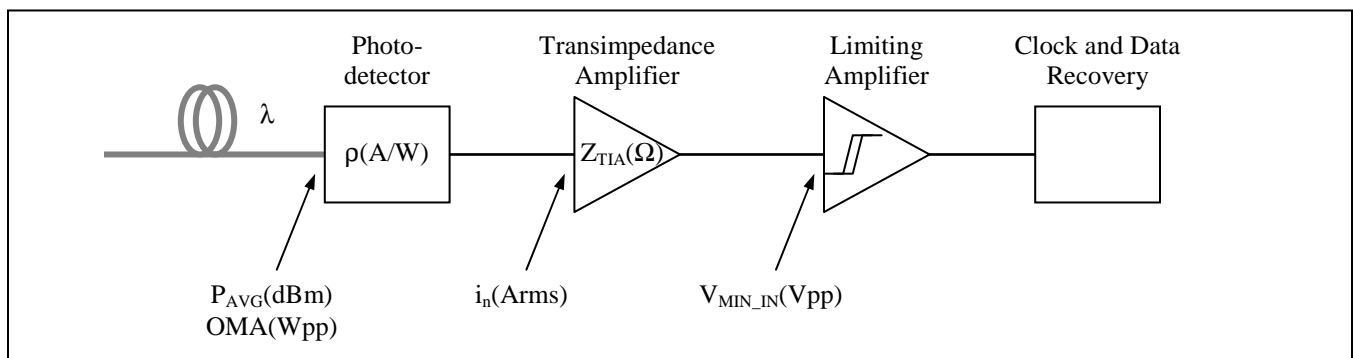

Figure 1. Simplified block diagram of the major functional blocks in an optical receiver

Transimpedance amplifiers (TIAs) are used to amplify and convert the photodiode current into a voltage. Usually included within the data sheets for a TIA is an equation for calculating the receiver's sensitivity. As listed in the [MAX3266/67 data sheet](#), the equation for calculating sensitivity is as follows:

$$Sensitivity = 10 \text{Log} \left( \frac{i_n SNR (r_e + 1)}{\rho (r_e - 1) 2} 1000 \right) \text{dBm}$$

This equation assumes that all of the noise in the system is due to the TIA. It also assumes that the limiting amp following the TIA has a decision threshold of zero. In reality, the result given by this equation is rarely obtainable; however, it is useful in comparing the relative differences among TIAs.

The noise of the TIA,  $i_n$ , is expressed as "input referred noise" in RMS current ( $A_{RMS}$ ) or "input referred noise density" in ( $A_{RMS}/\sqrt{\text{Hz}}$ ). This is the inherent noise of the amplifier. Input referred noise is directly proportional to the value of the photodiode capacitance and bandwidth of the TIA. The noise density has removed the bandwidth component so that it can be scaled to the specific

bandwidth used in the application. For this discussion, input referred noise will be used.

The process in estimating the minimum peak-to-peak swing of the optical signal begins with the choice of the maximum BER. This determines the signal-to-noise ratio (SNR). Next, the RMS input referred noise,  $i_n$ , of the TIA and the responsivity ( $\rho$ ) of the photodetector must be found from the vendor's data sheets. These are related by:

$$OMA_{MIN} = \frac{i_n SNR}{\rho} \tag{1}$$

The dimensions are as follows:

$$OMA_{MIN} = \frac{(Arms) \left( \frac{pp}{rms} \right)}{\left( \frac{A}{W} \right)} = W_{pp}$$

This relationship assumes that the noise is Gaussian. Therefore, the erred population of a logic one and a logic zero of a nonreturn-to-zero (NRZ) data stream can be estimated.

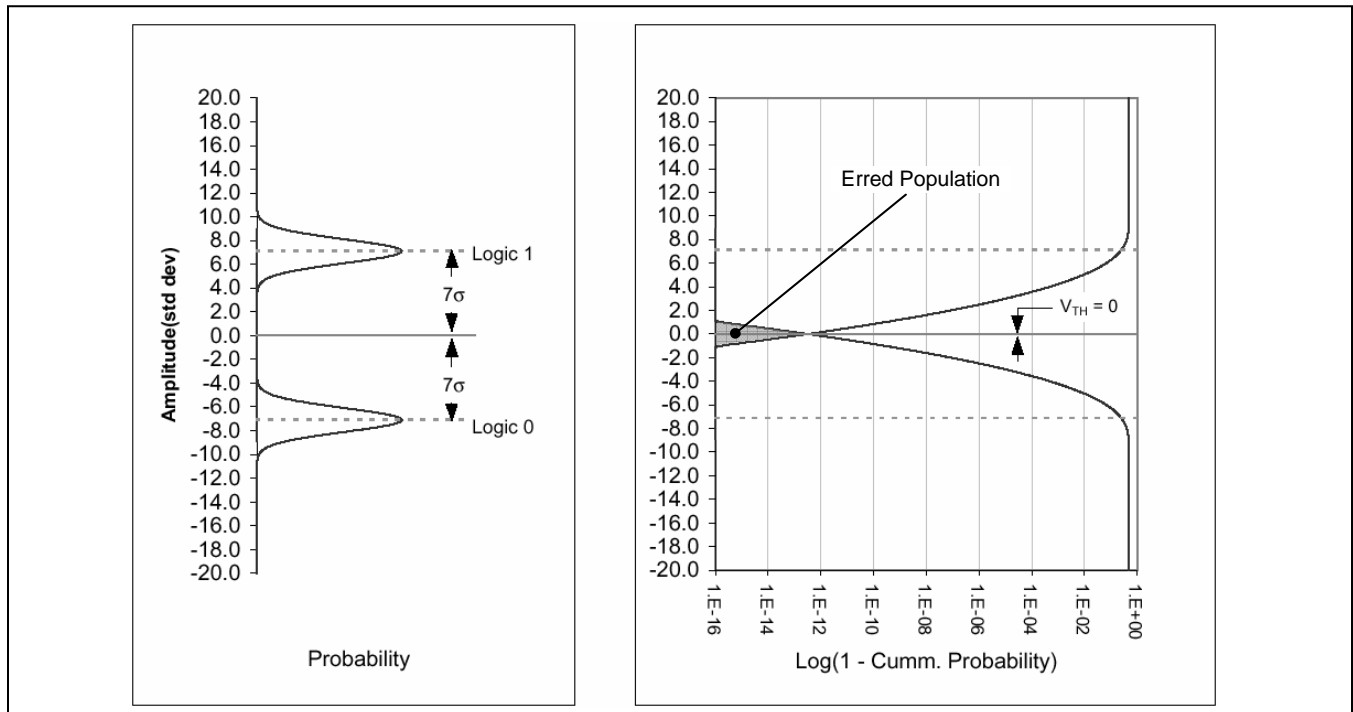

Figure 2. Noise distribution, as viewed linearly at the left, exhibits the familiar Gaussian distribution. Plotting the log(1-cummulative probability), at the right, reveals where the erred population is near the desired BER. With the decision threshold ( $V_{TH}$ ) of 0V, a  $BER < 10^{-12}$  is theoretically possible.

In Figure 2, the relationship of the normal probability to the erred population (1-cumulative probability) is shown as the region at which the occurrence rate of the erred bits equals the desired BER limit. The right side of Figure 2 shows the region overlapping where the BER = 10<sup>-12</sup>. The logic-one and logic-zero levels are each seven standard deviations ( $\pm 7\sigma$ ) away from a theoretical decision point shown at midscale. The application note, [Converting between RMS and Peak-to-Peak Jitter at a Specified BER](#), lists various SNRs for different BERs. Think of this SNR value as a way to convert an RMS value to a peak-to-peak value.

## 2.1 Example A

Consider this example:

If the desired BER = 10<sup>-12</sup>, the input referred noise  $i_n = 400\text{nA}/\text{rms}$ , and the responsivity  $\rho = 0.5\text{A}/\text{W}$ , what is the minimum optical modulation amplitude (OMA) and the minimum average optical power ( $P_{\text{AVG}}$ )?

For a BER of 10<sup>-12</sup>, the required SNR is 14.1 (see [Converting between RMS and Peak-to-Peak Jitter at a Specified BER](#)).

Applying Equation 1,

$$\begin{aligned} OMA_{\text{MIN}} &= \frac{i_n \text{SNR}}{\rho} = \frac{(400\text{nA})(14.1)}{(0.5\text{A}/\text{W})} \\ &= 11.3\mu\text{Wpp} \end{aligned}$$

Furthermore, if the extinction ratio, ( $P_1 / P_0$ ), is 8 (9dB), the average optical power is as follows:

$$\begin{aligned} P_{\text{AVG}} &= \frac{OMA(r_e + 1)}{2(r_e - 1)} \quad (\text{See appendix}) \\ &= \frac{(11.3\mu\text{W})(8 + 1)}{2(8 - 1)} \\ &= 7.25\mu\text{W} \end{aligned}$$

or in dBm:

$$= -21.4\text{dBm}$$

The traditional analysis leads us to conclude that the optical sensitivity is -21.4dBm. In reality, it is not. Although there might be many factors contributing to this, one glaring element has been omitted. In Figure 2, it is obvious that the vertical distance between a logic one and a logic zero is 0V. This means that the vertical eye is closed completely at the desired BER. The notion that a logic one and a logic zero can be detected with a threshold of 0V is preposterous!

## 3 Corrected Analysis

Once again, refer back to Figure 1. Note that the TIA is followed by a limiting amplifier. It has an input operating range over which the peak-to-peak signal at its input is amplified and clipped to maintain a constant amplitude. This range has a minimum signal swing below which the amplifier output is not held constant. This is the sensitivity of the limiting amplifier. To maintain the desired BER, the non-erred population must not cross into the sensitivity region of the limiting amplifier. In other words, the eye presented to the limiting amplifier must open by at least an amount equal to the limiting amplifier's sensitivity.

Figure 3 illustrates the impact of having a decision threshold greater than zero. Taking this into account, Equation 1 becomes

$$OMA_{\text{MIN}} = \frac{\left( i_n \text{SNR} + \left( \frac{V_{\text{TH}}}{Z_{\text{TIA}}} \right) \right)}{\rho} \quad (2)$$

where  $V_{\text{TH}}$  is the sensitivity of the limiting amplifier and  $Z_{\text{TIA}}$  is the transimpedance gain of the TIA.

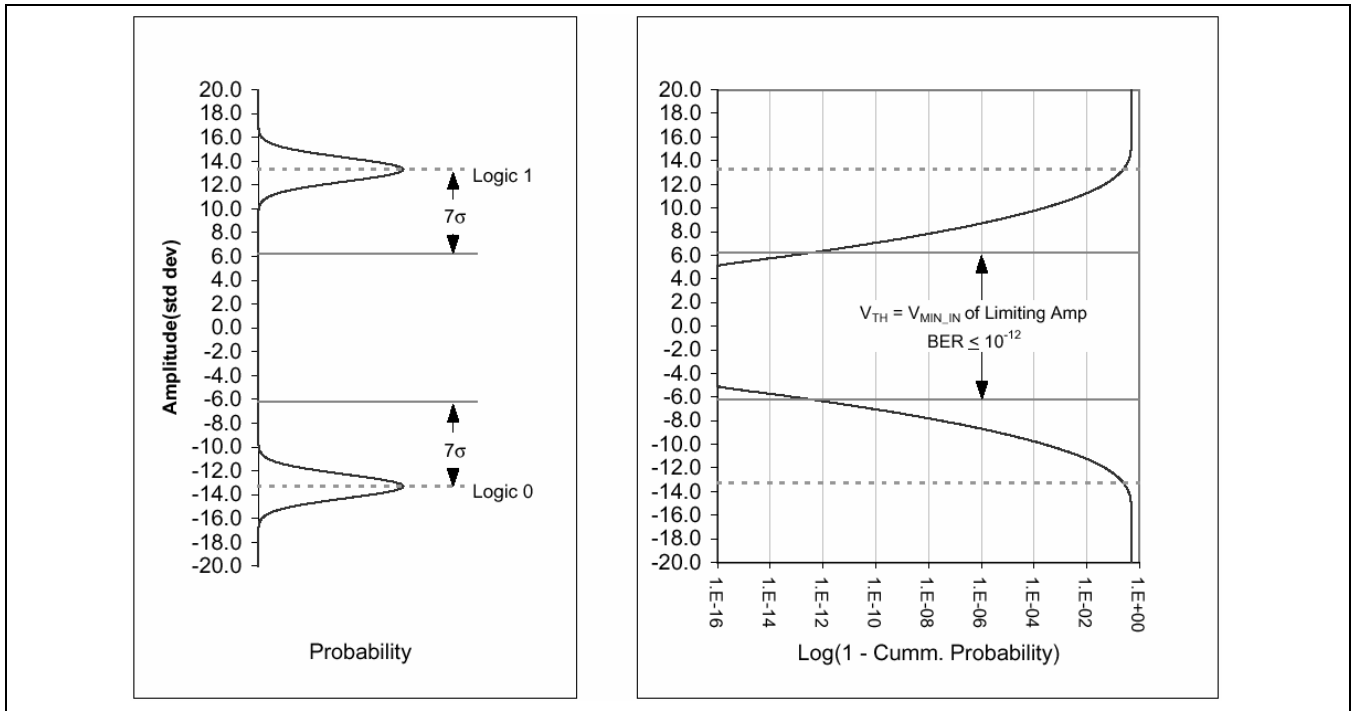

Figure 3. When the decision threshold is non-zero, the sensitivity of the next stage of the receiver must be considered. To achieve the desired BER for the receiver, the minimum input amplitude must be increased by an amount equal to the minimum input of the limiting amp,  $V_{MIN\_IN}$ .

### 3.1 Example B

Now consider Example A but with a decision threshold  $V_{TH} = 10\text{mVpp}$  and  $Z_{TIA} = 2\text{k}\Omega$ .

Applying Equation 2,

$$\begin{aligned}
 OMA_{MIN} &= \frac{\left( i_n SNR + \left( \frac{V_{TH}}{Z_{TIA}} \right) \right)}{\rho} \\
 &= \frac{\left[ (400\text{nA})(14.1) + \left( \frac{10\text{mV}}{2\text{k}\Omega} \right) \right]}{(0.5\text{ A/W})} \\
 &= 21.3\mu\text{W}
 \end{aligned}$$

The average optical power is

$$\begin{aligned}
 P_{AVG} &= \frac{OMA(r_e + 1)}{2(r_e - 1)} = \frac{(21.3\mu\text{W})(8 + 1)}{2(8 - 1)} \\
 &= 13.7\mu\text{W}
 \end{aligned}$$

or, in dBm,

$$= -18.6\text{dBm}$$

The difference between Examples A and B is nearly 3dB. This is a 2x change in optical sensitivity and cannot be ignored! This could be why many designers have adopted a rule of thumb to require an additional 3dB of sensitivity in the optical receiver section.

## 4 Conclusion

It is clear that the traditional analysis approach is oversimplified. With little effort, a more accurate estimate of optical sensitivity can be made. So, relying on a vendor specification meant for comparison-shopping or someone's rule of thumb should sound the alarm. By applying the technique presented in this discussion, it is easy to estimate and predict more realistic optical receiver sensitivity. In the end, there won't be any big surprises when you test your first parts!

## Appendix: Optical Terminology

**Optical modulation amplitude (OMA)** The difference between a logic-one power level ( $P_1$ ) and a logic-zero power level ( $P_0$ ), expressed as peak-to-peak watts, or  $W_{pp}$ .

**Average optical power ( $P_{AVG}$ )** The mean value of the optical power, expressed in dB milliwatts, or dBm.

**Responsivity ( $\rho$ )** Responsivity flux (conversion efficiency) of the photodetector (A/W).

**Extinction ratio ( $r_e$ )** The ratio of a logic-one power level ( $P_1$ ) relative to a logic-zero power level ( $P_0$ ). It can be expressed as:

$$r_e = \frac{P_1}{P_0} \quad \text{or} \quad r_e = 10 \log \left( \frac{P_1}{P_0} \right) (dB)$$

In some situations, it can be more convenient to use this form:

$$r_e = \frac{P_0}{P_1} \quad \text{or} \quad r_e = 100 \frac{P_0}{P_1} (\%)$$

**Signal-to-noise ratio (SNR)** Signal-to-noise ratio is required to achieve a specific BER. Notice that the signal is in terms of a peak-to-peak signal whereas the noise is in RMS terms. It is assumed that the noise is Gaussian. Another way of thinking about SNR is as an RMS to peak-to-peak conversion.

$$SNR = \frac{Signal_{(pp)}}{Noise_{(RMS)}}$$

The relationship of the linear ratio of extinction ratio,  $r_e$ , and OMA to average optical power,  $P_{AVG}$ , is as follows:

$$P_{AVG} = \frac{OMA(r_e + 1)}{2(r_e - 1)} (Watts)$$

or

$$P_{AVG} = 10 \log \left[ 1000 \frac{OMA(r_e + 1)}{2(r_e - 1)} \right] (dBm)$$

where  $r_e = \frac{P_1}{P_0}$