



## APPLICATION NOTE 604

# Fast Memory Transfers with the Ultra High-Speed Flash Microcontroller

*Abstract: The Dallas Semiconductor Ultra High-Speed Flash microcontroller features dual data pointers with auto increment/decrement and toggle select. This application note compares original 8051 architecture using one data pointer to the new architecture of the DS89C430 and DS89C450 and its improved efficiency in moving data. Numerous code examples are presented to help understand the use of the dual data pointers of this ultra high-speed microcontroller.*

## Overview

Embedded system designers and programmers are always searching for clever ways to push performance boundaries of their 8051 microcontroller designs. If your application is performance-limited by the rate at which the microcontroller can copy external data-memory buffers or read/write memory-mapped peripherals, you might benefit from a scheme that uses more on-chip hardware and less software. This application note introduces the use of a timer/counter as a means to terminate a fixed-length copy routine. Using this method with Dallas' Ultra High-Speed 8051 architecture and its data pointer enhancements, data can be copied at rates in excess of 2MBps, over 20 times faster than a standard 8051 core running at the same clock frequency and equipped with a single data pointer.

## XDATA Copy Routine-Original 8051

The original 8051 architecture contains only one data pointer ( $DPTR = DPH + DPL$ ), yet provides two different ways to indirectly access external data memory. The MOVX instruction can either use the 16-bit data pointer (e.g., MOVX @DPTR, A) or an 8-bit working register (e.g., MOVX @R0, A) to access MOVX data space. Note that the latter instruction uses an 8-bit register pointer, thus requiring that Port 2 be written with most significant address byte of the pointer prior to instruction execution. With only one data pointer, managing source and destination pointers when copying data in excess of 256 bytes requires heavy use of the working registers for temporary storage. Below is an example of code typically executed when copying data using a single data pointer.

```
; Original 8051 Copy - Single DPTR
; R6:R7 control copy length
; R4:R0 used for source/dest DPTR hi/lo temp storage
loop: ; Cycle Count @ 12clks/cycle
movx a,@dptr ; 2
inc dptr ; 2
xch a,r0 ; 1
xch a,dpl ; 1
xch a,r0 ; 1
xch a,r4 ; 1
xch a,dph ; 1
xch a,r4 ; 1
movx @dptr,a ; 2
inc dptr ; 2
xch a,r0 ; 1
xch a,dpl ; 1
xch a,r0 ; 1
xch a,r4 ; 1
xch a,dph ; 1
xch a,r4 ; 1
djnz r7,loop ; 2 => 22cycles * length
```

```
djnz r6,loop ; 2 => 2cycles * (1 + (length/256))
```

## XDATA Copy Routine-Ultra High-Speed Microcontroller

The Ultra High-Speed Microcontroller contains two data pointers (DPTR = DPH + DPL; DPTR1 = DPH1 + DPL1), which allows separate source and destination data pointers. In addition, it implements hardware controls to automatically toggle between the data pointers and automatically increment or decrement the active data pointer in response to certain DPTR-related instructions. Full details of the enhanced dual data pointers can be found in the Ultra High-Speed Microcontroller User's Guide. The code below demonstrates how the enhanced dual data pointers simplify the copy routine. Instructions that automatically toggle the active data pointer have been marked with a [T] and those that automatically advance the data pointer have been marked with a [+/-]. For the purpose of comparison with the original 8051 architecture, the standard 8051 external P2, P0 memory bus structure has been assumed, thus giving a minimum MOVX duration of 5 clock cycles (1 clock cycle for MOVX opcode fetch, 4 clock cycles for the data memory access). Although cycle counts for the Page Mode 1 external bus configuration are not reflected in the code example directly below, it should be noted that Page Mode 1 does provide the absolute minimum external MOVX duration (3 clock cycles = 1 clock cycle for the MOVX opcode fetch + 2 clock cycles for the data memory access).

```
; Ultra High-Speed Micro Copy - Enhanced Dual DPTRs
; DPS.4 (AID) = 1; DPS.5 (TSL) = 1;
; R6:R7 control copy length
loop: ; Cycle Count @ 1clk/cycle
movx a,@dptr ; 5 [T][+/-]
movx @dptr,a ; 5 [T][+/-]
djnz r7,loop ; 5=> 15 cycles * length
djnz r6,loop ; 5 => 5 cycles * (1 +(length/256))
```

## XDATA Copy Routine-Using A Timer/Counter

To use a timer/counter, the application must make available a timer/counter and its associated input pin for the duration of the copy routine. The basic idea is to use the on-chip counter to track and terminate the copy loop instead of using working registers. The Active-Low WR strobe serves as the input signal to the counter. **Figure 1** shows an example hardware configuration.

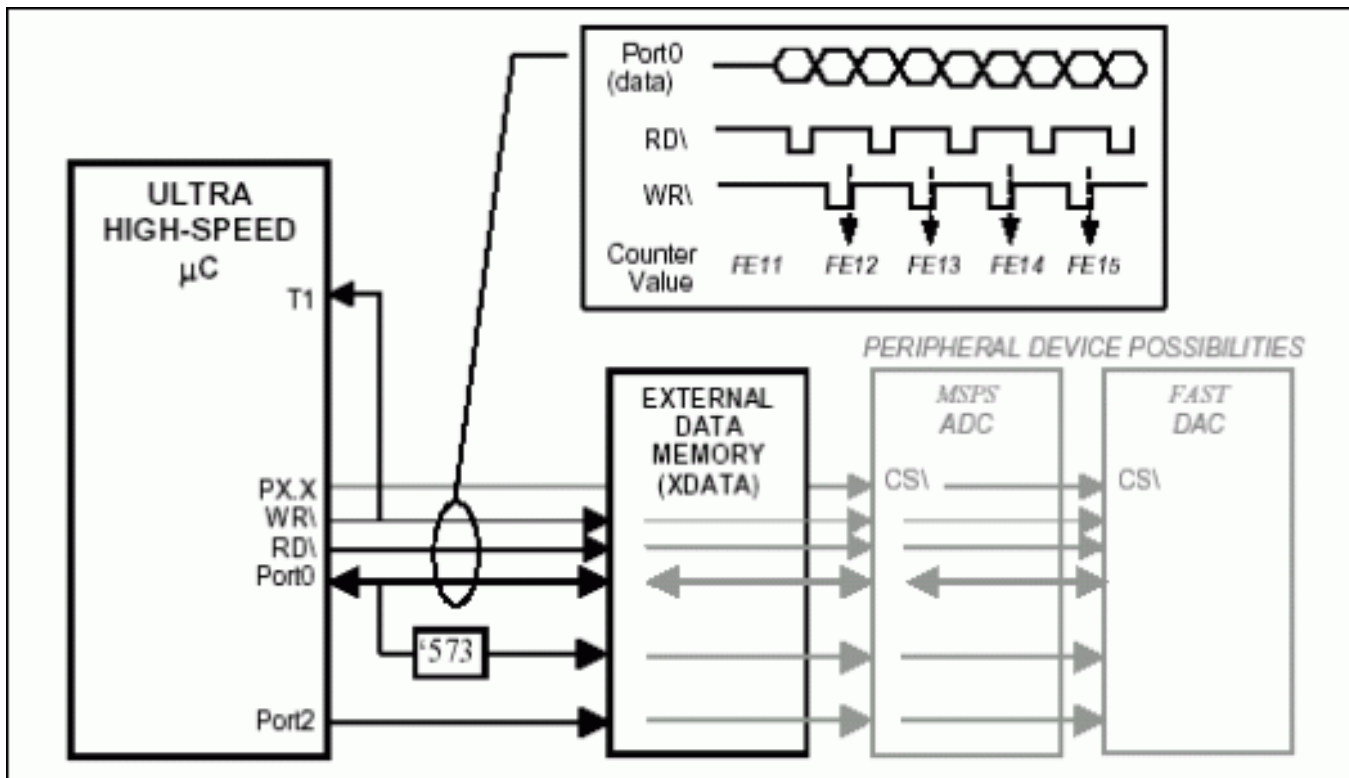

Figure 1. Hardware diagram for active-low wr strobe counting.

All Ultra High-Speed Microcontroller timer/counter input pins (T0, T1, T2) are able to sample an input frequency equivalent to one-quarter the system clock frequency. This means that the input signal to be sampled must have minimum high and low times of 2 system clock cycles each. Aside from fastest MOVX in 1-cycle or 2-cycle Page Mode 1, the Active-Low WR strobe meets this criteria for all other external MOVX operations. Before entering the copy loop, the 16-bit counter is loaded with the appropriate value ( $2^{16} - \text{\#bytes to copy}$ ), the timer/counter interrupt is enabled, and the enhanced data pointers are configured for the most expeditious copy. The last byte copied causes the counter to roll over and generates a timer interrupt, which allows code execution to be returned to the main program.

## Benefits of Using the Timer/Counter Method

The primary benefit of using a timer/counter is increased performance while allowing a more forgiving xdata access time. It has already been noted that the fastest copy loop execution time is achieved by configuring the external bus structure to Page Mode 1 (Port2 = multiplexed address MSB/LSB and Port0 = data). Although Page Mode 1 gives the ultimate performance, it also requires the fastest xdata access time ( $t_{RLDV} < t_{CLCL}$ ). The timer/counter method gives nearly the same performance while almost doubling maximum xdata access time.

Moreover, it is not expected that all Ultra High-Speed Microcontroller designs will use the new bus structure. Some system designers may wish to retain the legacy 8051 bus interface or may even be dropping an Ultra High Speed Microcontroller into an existing socket. Given these circumstances, the counter-terminated copy loop provides a high-performance compromise.

Because the timer/counter-terminated copy loop relies upon internal 16-bit timer hardware to count the number of external read/write events, it does not require separate DJNZ instructions to keep track of a 16-bit loop-control variable. This allows the application to conduct high-speed synchronous transfers for data lengths greater than 256 bytes.

Table 1 compares the copy loop for the original 8051 architecture versus three possible Ultra High-Speed Microcontroller configurations. The counter terminated copy loop has been highlighted. Following the table is an example code listing for a timer/counter-terminated copy. The copy loop has been highlighted in the code for comparison with the previous two examples.

**Table 1. Copy loop comparison.**

MICROCONTROLLER OPTION	Duration (ms) (1kbyte xdata copy-loop, sysclk=25MHz)	FAST XDATA ACCESS TIME ( $t_{RLDV}$ ) <sup>3</sup>	SYNCHRONOUS TRANSFER?	SPECIAL FEATURES USED
Ultra High-Speed Microcontroller <sup>1</sup>	0.441	$< 1 \times t_{CLCL}$	No	Page Mode 1 Bus Structure
Ultra High-Speed Microcontroller <sup>1</sup>	0.480	$< 2 \times t_{CLCL}$	Yes	Timer/Counter and Timer Input Pin
Ultra High-Speed Microcontroller <sup>1</sup>	0.601	$< 2 \times t_{CLCL}$	No	-
Standard 80512	10.568	$< 5 \times t_{CLCL}$	No	-

<sup>1</sup> Machine cycle =  $1 \times t_{CLCL}$ ; Enhanced Dual Data Pointers with Auto-Inc/Dec, Auto-Toggle

<sup>2</sup> Machine cycle =  $12 \times t_{CLCL}$ ; Single Data Pointer

<sup>3</sup>Reference individual device datasheets exact  $t_{RLDV}$  max values.

## Counter Terminated Copy Method (code example)

```

;-----
; Demonstrate use of Timer/Counter 1 to terminate copy loop
; Use P3.6 (Active-Low WR) as an input to Timer/Counter 1 (P3.5)
; In this example:

```

```

; 1) Source, dest, and length defined as constants.
; 2) Code saves only DPTR0 state under the assumption that a
; single DPTR is normally used and that the second (DPTR1)
; is enabled only for certain routines (such as this one).
; 3) Code disables all other interrupts during the copy.
; 4) External non-overlapping xdata to xdata transfer
;-----
#include(420.def) ; include file w/SFRs
source equ 0100h ; source xdata address
dest equ 0200h ; dest xdata address
length equ 256d ; #bytes to copy
;-----
org 0h
ljmp 0100h
;-----
;Timer/Counter 1 interrupt
;-----
org 1bh
clr tr1 ; disable timer/counter 1
pop acc ; pop 'ajmp' loop addr
pop acc ; from the stack
pop dps ; return pre-transfer
pop dph ; DPTR state
pop dpl
pop ie ; return interrupt config
pop eie
reti ; back to instruction
; after "xmemcpy_.." call
;-----
; Main
;-----
org 0100h
orl tmod, #50h ; 16-bit counter
anl ckcon, #0F8h ; fast 2-cycle MOVX
call xmemcpy_count ; call xdata copy code
sjmp $
;-----
; 1) Save interrupt enable registers, make only T/C#1 enabled
; 2) Save DPTR0
; 3) Timer/Counter 1 loaded with (2^16-#bytes to copy)
; 4) Configure source/destination pointers
; 5) Execute copy loop
; - last write rolls the Counter
; - Timer/Counter 1 Interrupt breaks the loop
;-----
xmemcpy_count:
push eie
push ie
mov eie, #00h ; disable other ints
mov ie, #88h ; EA=1, ET1=1
push dpl ;save DPTR state
push dph
push dps
mov th1, #high(-length) ; copy length
mov tl1, #low(-length)
setb tr1 ; enable Timer1
orl dps, #30h ; SEL=0,TSL=1, AID=1
mov dptr, #source ; DPTR0 = source addr
mov dptr, #dest ; DTPR1 = dest addr
transfer:
movx a, @dptr ;[5] read from @DPTR0
movx @dptr, a ;[5] write to @DPTR1
ajmp transfer ;[2] in loop •etil int

```

```
; ----  
; [12] total  
end
```

## Using Internal XRAM for Higher Transfer Rates

The basic principle of using a timer/counter to improve execution efficiency not only applies to external data copy routines, but can also be used for external data reads or writes to/from internal data memory. If, for instance, the application required no more than 1024 bytes be either read or written from external memory (or to/from a parallel peripheral), the internal 1kB data memory present on the DS89C430/450 could be used to further increase the transfer rate.

Since the internal MOVX operation requires only 2 cycles, the read/write transfer loop, which has been the subject of discussion to this point, could be reduced to 9 cycles for an effective transfer rate of 3.67MBps (@33MHz) and would occupy a mere 4B of code space (code below). Please remember that one of the two MOVX operations, either the read or the write, must be executed on external memory so that the Active-Low RD or Active-Low WR strobe increments the timer/counter, eventually terminating the transfer loop. The first code example below gives cycle counts corresponding to an external MOVX write and the second example shows an external MOVX read. Also note that when the Active-Low RD signal is counted, the counter should be initialized to  $[2^{16} - (\#bytes\ to\ copy + 1)]$  in order that the final byte write will occur before the loop is interrupted.

```
loop: ; Ultra High-Speed Microcontroller User's Guide Cycle Count / Byte Count  
movx a,@dptr ; 2 (internal MOVX) / 1  
movx @dptr,a ; 5 (external MOVX) / 1  
ajmp loop ; 2 / 2  
; 9 cycles / 4 bytes  
-- OR --  
loop: ; Ultra High-Speed Microcontroller User's Guide Cycle Count / Byte Count  
movx a,@dptr ; 5 (external MOVX) / 1  
movx @dptr,a ; 2 (internal MOVX) / 1  
ajmp loop ; 2 / 2  
; 9 cycles / 4 bytes
```

---

Application Note 604: <http://www.maxim-ic.com/an604>

### More Information

For technical questions and support: <http://www.maxim-ic.com/support>

For samples: <http://www.maxim-ic.com/samples>

Other questions and comments: <http://www.maxim-ic.com/contact>

### Related Parts

DS89C430: [QuickView](#) -- [Full \(PDF\) Data Sheet](#) -- [Free Samples](#)

DS89C450: [QuickView](#) -- [Full \(PDF\) Data Sheet](#) -- [Free Samples](#)

AN604, AN 604, APP604, Appnote604, Appnote 604

Copyright © by Maxim Integrated Products

Additional legal notices: <http://www.maxim-ic.com/legal>