



APPLICATION NOTE 600

Ultra High Speed Microcontroller Hardware Enhances Serial Port Capability

Abstract: This application note looks at the new serial port features found in the Dallas Semiconductor DS89C430 and DS89C450 ultra high-speed microcontrollers. The addition of a clock multiplier allows the user to benefit by selecting a crystal at one-fourth the original frequency to produce the same baud rates with reduced EMI.

Overview

In contrast to the original 8051 architecture that required a minimum of 12 clocks per instruction cycle, the Ultra High-Speed Microcontroller features an advanced 8051 core architecture capable of executing instructions in as little as one clock cycle. To complement the high performance core, new hardware features were integrated into the standard 8051 on-chip peripherals. Two of the new features, the clock multiplier and selectable high-speed clock to the timers, can directly affect baud rate generation for the serial ports. The purpose of this document is to explain the interaction between these two new features and serial-port baud-rate generation.

Serial Port Modes

The DS89C430 serial ports offer four basic modes of operation. Mode 0 allows half-duplex synchronous communication of 8-bit data using a baud clock derived from the system clock. Mode 1 allows full-duplex asynchronous communication of 8-bit data with a baud clock derived from Timer 1 or Timer 2. Mode 3 differs from Mode 1 by supporting 9-bit data transmission and reception. Mode 2 similarly provides 9-bit data communication, but instead derives its baud clock directly from the oscillator frequency. To support Mode 1, 2, and 3 asynchronous communication, a start bit always precedes the data and a stop bit always follows. Full details of each serial port mode can be found in the [Ultra High Speed Microcontroller User's Guide](#).

Clock Multiplier

The Ultra High Speed Microcontroller incorporates an on-chip clock multiplier to give increased performance at a reduced external crystal clock frequency. The multiplier can be configured to generate either a doubled (2X) or quadrupled (4X) internal system clock, controlled by the 2X/4X special function register bit (PMR.3). Please note that the resultant 2X or 4X multiplied system clock still cannot exceed the maximum operating frequency specified in the data sheet. Full details pertaining to the multiplier can be found in the [Ultra High Speed Microcontroller User's Guide](#).

Once the clock multiplier output has been selected (CD1:0 = 00b) as the internal system clock, certain serial port baud clocks derived from the system clock (no longer equal to the external oscillator frequency) will change. **Figure 1** highlights the serial port clocks potentially affected when using the 2X or 4X multiplied system clock. The Serial Mode 0 baud rate will always differ, Serial Mode 2 baud rate will never differ, and the Serial Mode 1, 3 baud rates can differ, depending upon the timer used and/or timer input clock selection. Table 1, as per Figure 1, denotes which serial port modes are affected by use of the clock multiplier. Appendix A contains detailed equations for performing baud rate calculations when using the 2X or 4X clock multiplier mode.

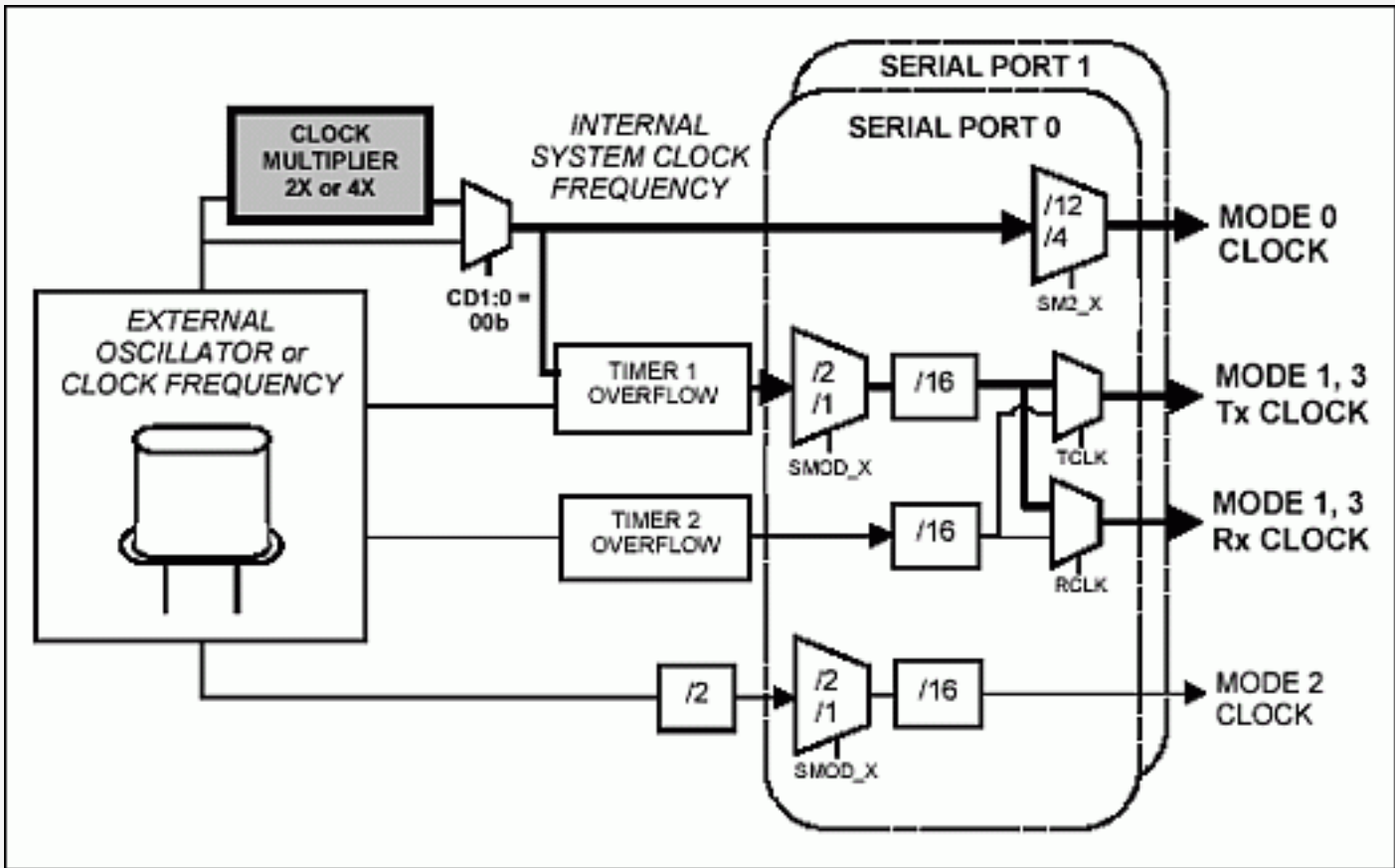

Figure 1. Serial port clocks affected by selection of the clock multiplier output (CD1:0 = 00b).

Table 1. Serial port baud clocks dependent on the system clock

SERIAL PORT MODE	BAUD CLOCK SOURCE	BAUD CLOCK DEPENDENT ON THE INTERNAL SYSTEM CLOCK (CLOCK MULTIPLIER SELECTION)
Mode 0 (synchronous - 8 bits)	System Clock/4 System Clock/12	YES
Mode 1 (asynchronous - 10 bits)	Timer 1 Timer 2	YES ¹ NO ²
Mode 2 (asynchronous - 11 bits)	Oscillator Clock/32 Oscillator Clock/64	NO
Mode 3 (asynchronous - 11 bits)	Timer 1 Timer 2	YES ¹ NO ²

¹ Only when the divide by 4 or divide by 1 Timer 1 input clock is enabled (T1M = 1 or T1MH = 1). For compatibility with the original 8051, the default Timer 1 input clock (T1MH, T1M = 00b) is fixed to the oscillator clock divided by 12.

² Available for baud rate generation on Serial Port 0 only.

Benefits: Faster Baud Rates, Reduced EMI

When using the clock multiplier, the application benefits can be great. An external crystal clock of one-fourth the original frequency can be used to produce the same Serial Mode 0 and (Timer 1 generated) Mode 1, 3 baud rates as before, but with much reduced EMI. Alternatively, the same external crystal, when multiplied internally by 2X or 4X, can now generate baud clocks up to four times faster!

High-Speed Input Clock to Timers

In order for the on-chip timers to be most useful to the application, each should be able to track time at a rate equivalent to the minimum instruction cycle. For the original 8051 architecture, which executed instructions in 12 oscillator clocks, the timers were clocked at an oscillator frequency divided by 12 rate. When Dallas Semiconductor introduced its high-speed microcontroller with a reduced machine cycle of four oscillator clocks, a selectable oscillator frequency divided by 4 input-clock control was provided for each timer. When the clock multiplier function was added to the high-speed microcontroller family, the selectable divide by 4 timer-input clock was modified to become a function of the system clock, not the oscillator clock. Now, the Ultra High-Speed Microcontroller boasts single clock-cycle instruction execution. Once again, each of the on-chip timers has been upgraded with the integration of a selectable system clock divide by 1 input.

The T0MH, T1MH, and T2MH bits, contained in the CKMOD (96h) SFR, respectively enable the system clock divide by 1 input to Timer 0, Timer 1, and Timer 2. Enabling the high-speed system-clock input to the timer (TxMH = 1) will automatically override the system clock divided by 4 input (TxM = 1) setting. The new system clock divide by 1 timer input, like the system clock divide by 4 input, factors into baud rate generation when using Timer 1. **Figure 2** highlights the serial port clocks potentially affected by selection of the high-speed clock input to Timer 1.

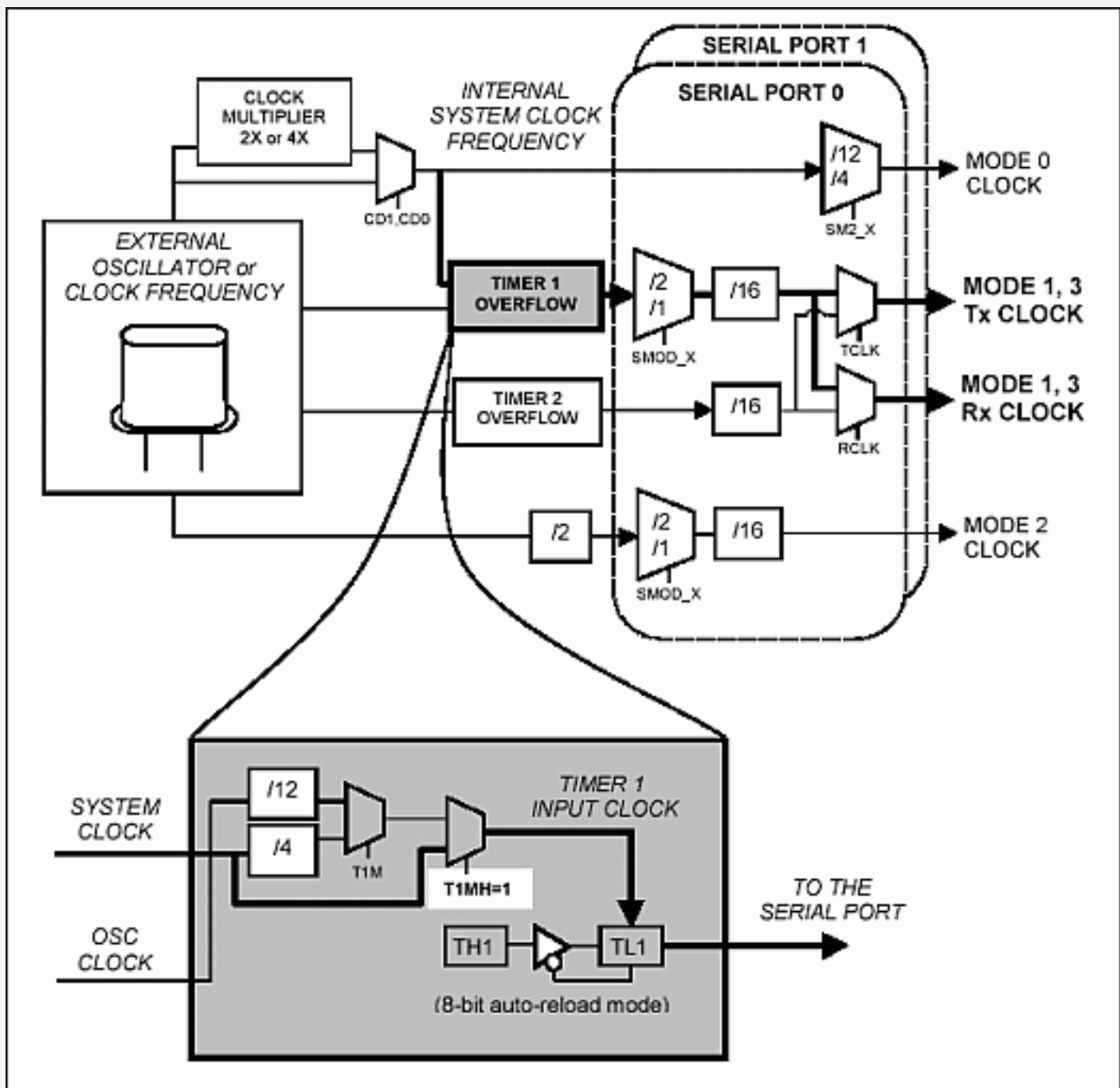

Figure 2. Serial port clocks affected by selection of high-speed timer 1 input ($T1MH = 1$).

Benefits: Faster Baud Rates, Increased Baud Rate Resolution

Relative to serial port operation, the divide by 1 input-clock feature translates into two user benefits. First, provided with the same system clock frequency, baud rates four times faster can now be generated for Serial Modes 1 and 3 when using Timer 1. Secondly, clocking Timer 1 faster allows higher baud rate resolution, potentially reducing error associated with baud rates already used by the application, or bringing new baud rates within an acceptable error range for application use.

For example, suppose a user currently has a Dallas high-speed microcontroller application running at a 20MHz system clock frequency. The application uses one of the serial ports for RS232 communication with a PC, and requires that the baud rate mismatch between the two be $< 3\%$. If using Timer 1 (in the 8-bit auto-reload mode) for baud rate generation, Table 2 below gives a sampling of the "good" baud rates for the Dallas high-speed microcontroller versus those for the new Ultra High Speed Microcontroller. The unacceptable baud rates (those with mismatch $> 3\%$) have been shaded in gray. Table 3 makes the same "good" baud rate comparison for a system clock frequency of 25MHz. As one can plainly see, enabling the high-speed Timer 1 input clock gives

much finer baud rate resolution. Appendix A contains detailed equations for performing baud rate calculations when utilizing the system clock input to Timer 1 (T1MH = 1).

Table 2. High-speed microcontroller vs. ultra high-speed microcontroller timer 1 baud rate generation capability (SYSCLK = 20MHz)

PC UART (8250/16450)		HIGH-SPEED MICROCONTROLLER (Timer 1 with T1M = 1 used for baud rate generation, SMOD_x = 1)		ULTRA HIGH-SPEED MICROCONTROLLER (Timer 1 with T1MH = 1 used for baud rate generation, SMOD_x = 1)	
Reload	Baud Rate	Baud Rate (TH1)	% Error	Baud Rate (TH1)	Error
1	115200	104166 (FD)	-9.6	113636 (F5)	-1.4
2	57600	62500 (FB)	8.5	56818 (EA)	-1.4
3	38400	39062 (F8)	1.7	37879 (DF)	-1.4
4	28800	28409 (F5)	-1.4	29070 (D5)	0.9
5	23040	22321 (F2)	-3.1	23148 (CA)	0.5
6	19200	19531 (F0)	1.7	19231 (BF)	0.2
7	16457	16447 (ED)	-0.1	16447 (B4)	-0.1
8	14400	14204 (EA)	-1.4	14368 (A9)	-0.2
9	12800	13020 (E8)	1.7	12755 (9E)	-0.4
10	11520	11574 (E5)	0.5	11574 (94)	0.5
11	10472	10417 (E2)	-0.5	10417 (88)	-0.5
12	9600	9469 (DF)	-1.4	9615 (7E)	0.2

Table 3. High-speed microcontroller vs. ultra high-speed microcontroller timer 1 baud rate generation capability (SYSCLK = 25MHz)

PC UART (8250/16450)		HIGH-SPEED MICROCONTROLLER (Timer 1 with T1M = 1 used for baud rate generation, SMOD_x = 1)		ULTRA HIGH-SPEED MICROCONTROLLER (Timer 1 with T1MH = 1 used for baud rate generation, SMOD_x = 1)	
Reload	Baud Rate	Baud Rate (TH1)	% Error	Baud Rate (TH1)	Error
1	115200	130208 (FD)	13.0	111607 (F2)	-3.1
2	57600	55803 (F9)	-3.1	57870 (E5)	0.4
3	38400	39062 (F6)	1.7	38110 (D7)	-0.8
4	28800	27901 (F2)	-3.1	28935 (CA)	0.5
5	23040	22978 (EF)	-0.3	22978 (BC)	-0.3
6	19200	19531 (EC)	1.7	19290 (AF)	0.5
7	16457	16276 (E8)	-1.1	16447 (A1)	-0.1
8	14400	14467 (E5)	0.5	14335 (93)	-0.5
9	12800	12600 (E1)	-1.6	12807 (86)	0.1
10	11520	11489 (DE)	-0.3	11489 (78)	-0.3
11	10472	10557 (DB)	0.8	10487 (6B)	0.1
12	9600	9527 (D7)	-0.8	9586 (5D)	-0.1

Application Example #1

SPI Mode (1,1) Interface Using Synchronous Serial Mode 0

While one can interface to an SPI™ device by "bit-banging" port pins, using synchronous Serial Mode 0 reduces software overhead and allows faster communication speed. The synchronous serial mode of operation provides a shift clock on the TXD pin and writes/reads serial data on the RXD pin at each rising edge of the shift clock (TXD). Since TXD idles in the high state, the synchronous serial mode aligns closely with the CPOL = 1, CPHA = 1 SPI Mode. Since the synchronous serial mode does not require a 3-sample majority-voting scheme for each bit (like the asynchronous serial modes), it is capable of achieving baud rates faster than any other serial mode. The figure below illustrates an interface between the DS89C430 microcontroller and an SPI mode (1,1) compatible EEPROM device.

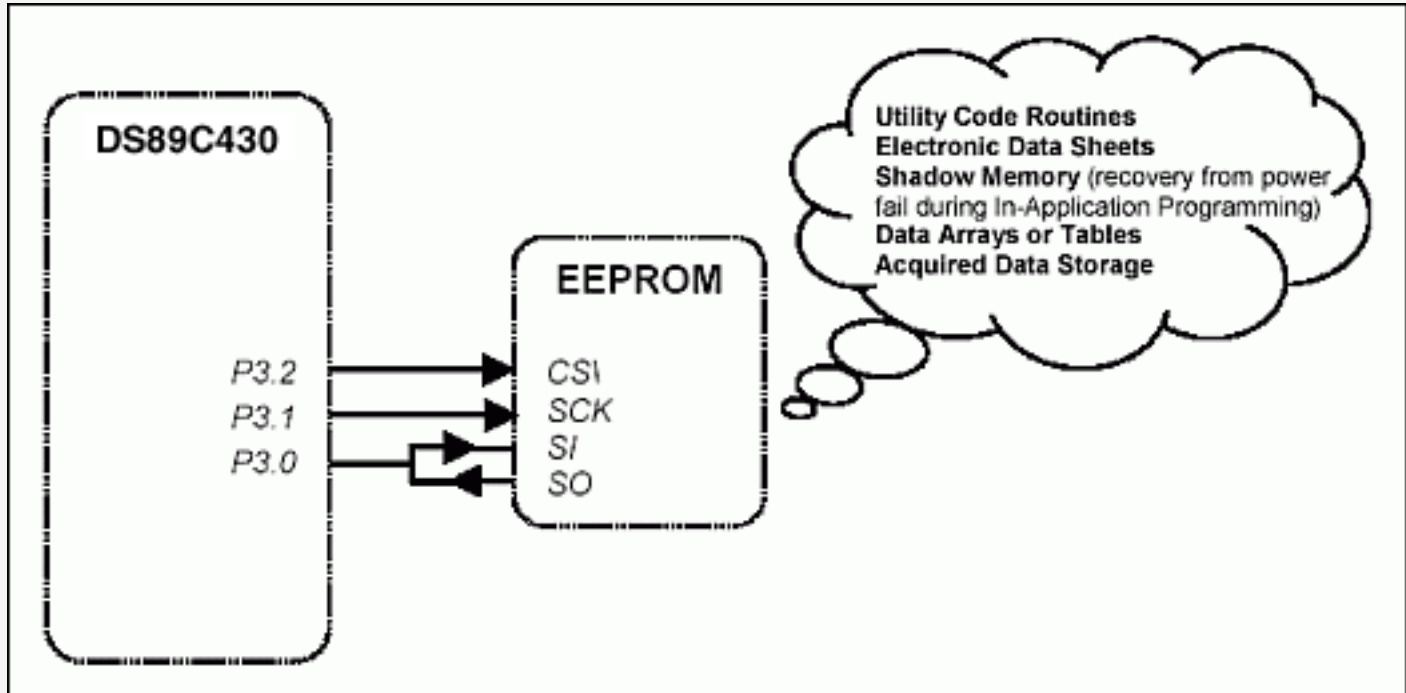

Figure 3. Example serial port interface to an spi-compatible peripheral.

Serial Port 0 is first placed into Mode 0 and configured to produce a system clock divide by 4 baud clock. Depending upon the timing restrictions of the attached SPI peripheral, a reduced system clock or system clock divide by 12 baud clock may need to be selected. Externally, the TXD pin (P3.1) provides the serial clock and connects to the SCK input of the EEPROM. The RXD pin (P3.0) handles all SPI data transactions via its connection to both the SI input and SO output of the EEPROM. The ability to use a shared SI/SO configuration will depend upon the I/O timing of the attached SPI peripheral. A third microcontroller port pin, not linked to the on-chip serial port hardware, serves as the SPI peripheral chip select input. In this example, port pin P3.2 will be connected to the EEPROM active-low CS input and will be manually asserted and de-asserted by the software. Since the serial port communicates LSB first and the SPI peripheral expects to communicate MSB first, a lookup table is used for byte translation in most cases.

Two routines, *XRAM_store* and *XRAM_recall*, have been created and do exactly as their names would simply. The *XRAM_store* routine writes the current contents of the internal 1kB SRAM to a specified 1kB range of EEPROM, while *XRAM_recall* reads the specified 1kB range of EEPROM into the DS89C430 on-chip SRAM. This code is intended only as an example and could easily be adapted to access different address ranges of the microcontroller or EEPROM memory, in smaller or larger blocks.

Code Listing: SPI Interface Using Synchronous Serial Port

```
;-----  
; DS89C430 SPI I/F example code  
;  
; 420 pin SPI I/F pin  
; -----  
; P3.2 Active-Low CS  
; P3.1/TXD SCK  
; P3.0/RXD SI,SO  
;-----  
$include(420.def) ;SFR equates  
ee_cs bit p3.2 ;EEPROM Active-Low CS  
;-----  
; SPI EEPROM opcodes - (CAT25C64 used)  
;  
; (bits in each byte are reversed since serial communication  
; is lsb-first whereas SPI communication is msb-first).  
;-----  
ee_wren equ 01100000b ;=06h  
ee_rdsr equ 10100000b ;=05h  
ee_read equ 11000000b ;=03h  
ee_write equ 01000000b ;=02h  
;-----  
; constants  
;-----  
eepg equ 64d ;64byte page writes (CAT25C64)  
xdb equ 1024d ;1KB xdata block  
;-----  
; Main Program  
;-----  
org 0000h  
;-----  
; Serial Port 0: Mode 0, baud clock=sysclk/4  
; (Note: Tested @ sysclk = 25 MHz; SPI baud clock = 6.25 MHz.  
; A reduced system clock frequency or sysclk/12 baud clock  
; may be required depending on SPI device timing)  
;-----  
mov scon, #20h ; mode 0, sysclk/4 clk  
; mov scon, #00h ; mode 0, sysclk/12 clk  
;-----  
; XRAM store/recall example  
;-----  
orl pmr, #01h ; Enable 1KB XRAM  
;==> COPY CODE (0-03FFh) INTO XRAM DATA (0-03FFh)  
mov dps, #30h ; dptr auto-inc/tog <ON>  
mov dptr, #0000h ; code dptr  
mov dptr, #0000h ; xram dptr  
copy:  
clr a  
movc a, @a+dptr ; read from code  
movx @dptr, a ; write to data  
mov a, dph  
cjne a, #04h, copy ; dptr=0400h yet?  
mov dps, #00h ; dptr auto-inc/tog <OFF>  
;==> STORE XRAM TO EEPROM BLOCK 0 (0000h - 03FFh)  
clr a ; a=00h (=EEPROM block 0)  
call XRAM_store ; store to EEPROM  
;==> FILL XRAM WITH FFh DATA  
call fx ; fill XRAM with FFh data
```

```

;==> RECALL EEPROM BLOCK 0 (0000h - 03FFh) TO XRAM
clr a ; a=00h (=EEPROM block 0)
call XRAM_recall ; recall from EEPROM
sjmp $
;-----
; XRAM_store (a)
; acc: selects 1KB EEPROM block to store XRAM
; 00 -> 0000h-03FFh
; 01 -> 0400h-07FFh
; ..
; 07 -> 1C00h-1FFFh
; r5: local counter = pages left to write
;-----
XRAM_store:
mov dps, #01h ; dptrl= source (XRAM)
mov dptr, #0000h ; dptrl= 0000h
mov r5, #(xdb/eepg) ; 1024/64 = 16
rl a ; rotate block index left
rl a ; twice to get msb addr
mov dph, a ; dptr = dest (EEPROM)
mov dpl, #00h
write:
call wren ; _____WREN_____
wel_wait:
call rdsr ; _____RDSR_____
jnb acc.1, wel_wait ; poll for WEL bit = 1
clr ee_cs ; Active-Low CS = 0
mov sbuf, #ee_write ; _____WRITE_____
jnb ti, $ ; command sent
clr ti
mov a, dph ; get dest msb addr
call bitrev ; use LUT to transpose byte
mov sbuf, a ; _____<MSB>_____
jnb ti, $ ; <MSB> sent
clr ti
mov a, dpl ; get dest lsb addr
call bitrev ; use LUT to transpose byte
mov sbuf, a ; _____<LSB>_____
jnb ti, $ ; <LSB> sent
clr ti
orl dps, #30h ; dptr auto-inc/tog <ON>
write_64:
movx a, @dptr ; dptrl XRAM read
call bitrev ; use LUT to transpose byte
mov sbuf, a ; _____<DATA>_____
inc dptr ; inc dest dptr
mov a, dpl ; check dest dptr for page
anl a, #(eepg-1) ; write multiple (64d)
jnb ti, $ ; <DATA> sent
clr ti
jnz write_64 ; 64bytes written?
setb ee_cs ; Active-Low CS=1
rdypoll:
call rdsr ; _____RDSR_____
jb acc.0, rdypoll ; poll for RDY bit = 0
djnz r5, write ; all pages written?
anl dps, #0cfh ; dptr auto-inc/tog <OFF>
ret
;-----
; XRAM_recall (a)
; acc: selects 1KB EEPROM block to copy into XRAM

```

```

; 00 -> 0000h-03FFh
; 01 -> 0400h-07FFh
; ..
; 07 -> 1C00h-1FFFh
; r5: local counter of 256byte pages left to read
;-----
XRAM_recall:
mov dps, #01h ; dptr1 = dest (XRAM)
mov dptr, #0000h ; dptr1 = 0000h
mov r5, #(xdb/256) ; 1024/256 = 4
rl a ; rotate block index left
rl a ; twice to get msb addr
clr ee_cs ; Active-Low CS = 0
mov sbuf, #ee_read ; _____READ_____
jnb ti, $ ; command sent
clr ti
call bitrev ; use LUT to transpose byte
mov sbuf, a ; _____<MSB>_____
jnb ti, $ ; msb sent
clr ti
mov sbuf, #00h ; _____<LSB>_____
jnb ti, $ ; lsb sent
clr ti
setb ri ; don't receive yet
setb ren ; enable receive
orl dps, #10h ; dptr auto-inc <ON>
read:
clr ri ; _____<DATA>_____
jnb ri, $ ; got data
mov a, sbuf
call bitrev ; use LUT to transpose byte
movx @dptr, a ; dptr1 XRAM write
mov a, dp11 ; check dest dptr for 256
jnz read ; byte boundary
djnz r5, read ; all pages read?
clr ren ; disable receive
clr ri
setb ee_cs ; Active-Low CS = 1
anl dps, #0efh ; dptr auto-inc <OFF>
ret
;-----
; EEPROM commands: WREN, RDSR
;-----
wren:
clr ee_cs ; Active-Low CS = 0
mov sbuf, #ee_wren ; _____WREN_____
jnb ti, $ ; command sent
clr ti
setb ee_cs ; Active-Low CS = 1
ret
rdsr:
clr ee_cs ; Active-Low CS = 0
mov sbuf, #ee_rdsr ; _____RDSR_____
jnb ti, $ ; command sent
clr ti
setb ren ; enable receive
jnb ri, $ ; got data
clr ren ; disable receive
clr ri
setb ee_cs ; Active-Low CS = 1

```

```

mov a, sbuf
call bitrev ; use LUT to transpose byte
ret
;-----
; fill XRAM with FFh data
;-----
fx:
mov dps, #10h ; dptr auto-inc <ON>
mov dptr, #0000h
fx1:
mov a, #0ffh
movx @dptr, a
mov a, dph
cjne a, #04h, fx1
mov dps, #00h ; dptr auto-inc <OFF>
ret
;-----
; bit reversal LUT
;-----
bitrev:
jnz do_lookup ; no lookup if a=00h
ret ; since 00h transposed = 00h
do_lookup:
movc a, @a+pc
ret
db 080h,040h,0C0h,020h,0A0h,060h,0E0h
db 010h,090h,050h,0D0h,030h,0B0h,070h,0F0h
db 008h,088h,048h,0C8h,028h,0A8h,068h,0E8h
db 018h,098h,058h,0D8h,038h,0B8h,078h,0F8h
db 004h,084h,044h,0C4h,024h,0A4h,064h,0E4h
db 014h,094h,054h,0D4h,034h,0B4h,074h,0F4h
db 00Ch,08Ch,04Ch,0CCh,02Ch,0ACh,06Ch,0ECh
db 01Ch,09Ch,05Ch,0DCh,03Ch,0BCh,07Ch,0FCh
db 002h,082h,042h,0C2h,022h,0A2h,062h,0E2h
db 012h,092h,052h,0D2h,032h,0B2h,072h,0F2h
db 00Ah,08Ah,04Ah,0CAh,02Ah,0AAh,06Ah,0EAh
db 01Ah,09Ah,05Ah,0DAh,03Ah,0BAh,07Ah,0FAh
db 006h,086h,046h,0C6h,026h,0A6h,066h,0E6h
db 016h,096h,056h,0D6h,036h,0B6h,076h,0F6h
db 00Eh,08Eh,04Eh,0CEh,02Eh,0AEh,06Eh,0EEh
db 01Eh,09Eh,05Eh,0DEh,03Eh,0BEh,07Eh,0FEh
db 001h,081h,041h,0C1h,021h,0A1h,061h,0E1h
db 011h,091h,051h,0D1h,031h,0B1h,071h,0F1h
db 009h,089h,049h,0C9h,029h,0A9h,069h,0E9h
db 019h,099h,059h,0D9h,039h,0B9h,079h,0F9h
db 005h,085h,045h,0C5h,025h,0A5h,065h,0E5h
db 015h,095h,055h,0D5h,035h,0B5h,075h,0F5h
db 00Dh,08Dh,04Dh,0CDh,02Dh,0ADh,06Dh,0EDh
db 01Dh,09Dh,05Dh,0DDh,03Dh,0BDh,07Dh,0FDh
db 003h,083h,043h,0C3h,023h,0A3h,063h,0E3h
db 013h,093h,053h,0D3h,033h,0B3h,073h,0F3h
db 00Bh,08Bh,04Bh,0CBh,02Bh,0ABh,06Bh,0EBh
db 01Bh,09Bh,05Bh,0DBh,03Bh,0BBh,07Bh,0FBh
db 007h,087h,047h,0C7h,027h,0A7h,067h,0E7h
db 017h,097h,057h,0D7h,037h,0B7h,077h,0F7h
db 00Fh,08Fh,04Fh,0CFh,02Fh,0AFh,06Fh,0EFh
db 01Fh,09Fh,05Fh,0DFh,03Fh,0BFh,07Fh,0FFh
end

```

Application Example #2

RS-485 Networking Using Asynchronous Serial Mode 3

The asynchronous serial port modes transmit and receive data in a format that is compatible with the universally accepted RS-232 protocol. The Ultra High Speed Microcontroller, when running at its maximum system clock frequency (33MHz) and using the system clock Timer input (T1MH = 1), can achieve asynchronous baud rates in excess of 2Mbaud. (The Ultra High Speed Microcontroller contains a table showing the maximum baud rates for each serial mode). Unfortunately, to comply with the physical requirements of the RS-232 standard, RS-232 transmitters must provide a minimum output voltage swing of $\pm 5V$ and yet not exceed a $30V/\mu s$ slew rate. These restrictions generally confine RS-232 compliant communication to slower baud rates, and short line lengths. The limitations associated with the RS-232 standard should not, however, prevent the use of the asynchronous serial modes when higher transmission rates are required. First of all, RS-232 "compatible" (not compliant) transceivers, capable of MegaBaud™ operation, are currently available from Maxim/Dallas. For details about MegaBaud RS-232-compatible transceivers, please visit the Maxim/Dallas website (www.maxim-ic.com). Secondly, point-to-point connection between multiple microcontrollers and/or other asynchronous serial devices allows creation of user-defined networks that can communicate at faster baud rates. Additionally, there are physical layer protocols (e.g., RS-422 and RS-485) that support high-speed asynchronous serial communication over greater distances.

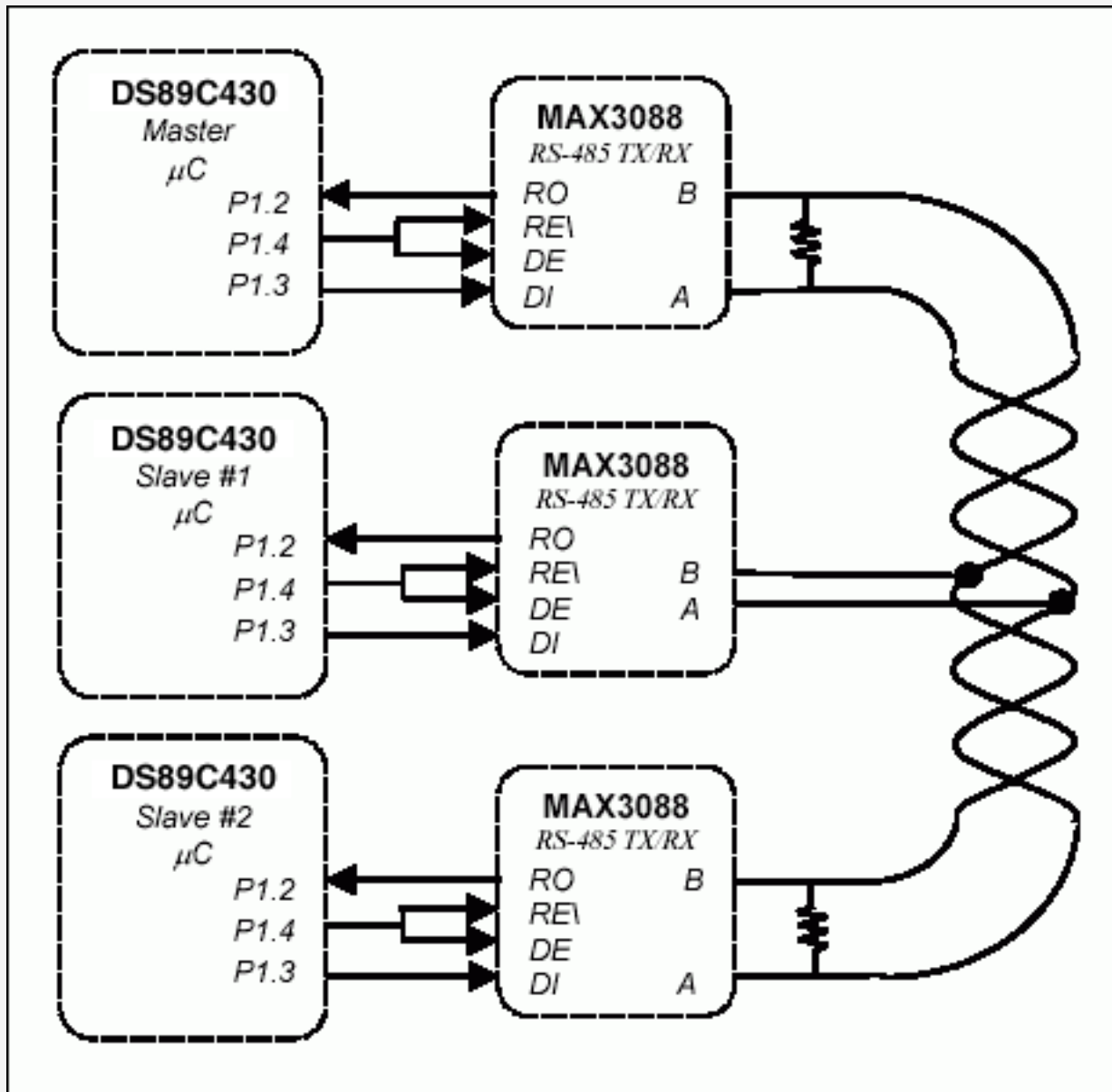

Figure 4. Example RS-485 networking using hardware serial port interfaces.

The figure above diagrams an RS-485 network interface between (3) DS89C430 microcontrollers. The asynchronous serial modes use the TXD pin for transmission and the RXD pin for reception. These pins connect directly to the DI (data input) and RO (receive output) pins of the RS-485 transceiver. A third microcontroller port pin, P1.4, is connected to both the DE (data enable) and active-low RE (receive enable) and will serve as the directional control for the half-duplex transceiver. The network uses a master/slave architecture (1 master, 2 slaves), where each slave device has its own unique address and must first be addressed by the master before transmitting on the bus. All devices are operated at a 22.1184MHz system clock frequency and use Timer 1 to produce a 1.38M baud rate. The settings needed to generate this baud rate can be found in Table 4 following the figure.

Table 4. Asynchronous mode 1, 3 baud rate vs. system clock (RLCK = 0, TCLK = 0, T1MH = 1, SMOD_x = 1)

SYSTEM CLOCK (MHz)	EXTERNAL CRYSTAL OR CLOCK FREQUENCY (MHz)	CLOCK MULTIPLIER MODE ²	TIMER 1 RELOAD VALUE				
			FB	FC	FD	FE	FF
7.3728	7.3728	-	92,160	115,200	153,600	230,400	460,800
10.0000	10.0000	-	125,000	156,250	208,333	312,250	625,000
11.0592	11.0592	-	138,240	172,800	230,400	345,600	691,200
14.7456	7.3728	2X	184,320	230,400	307,200	460,800	921,600
16.0000	16.0000	-	200,000	250,000	333,333	500,000	1,000,000
18.4320	18.4320	-	230,400	288,000	384,000	576,000	1,152,000
20.0000	10.0000	2X	250,000	312,250	416,667	625,000	1,250,000
22.1184	11.0592	2X	276,480	345,600	460,800	691,200	1,382,400 ¹
25.0000	25.0000	-	312,500	390,625	520,833	781,250	1,562,500
29.4912	7.3728	4X	368,640	460,800	614,400	921,600	1,843,200
32.0000	16.0000	2X	400,000	500,000	666,667	1,000,000	2,000,000
33.0000	33.0000	-	412,500	515,625	687,500	1,031,250	2,062,500

¹ Baud rate used in Application Example #2.

² The clock multiplier is used for illustration and is not required to generate these system clock frequencies.

Code Example: Master Code

The master device is initialized as the transmitter and drives the DE, active-low RE pins of its transceiver to logic high. After transmitting the slave address, the master places the transceiver into receive mode. Upon reception of two data bytes from the slave, the master returns the transceiver to its transmit mode. The master uses 13-bit Timer 0 to time-out if two data bytes are not received from the addressed slave within a certain period of time. The master sends the slave address and received data bytes (or an indication that no response was received) to Serial Port 0 before addressing the other slave.

```

;-----
; DS89C430 RS-485 I/F example
; Master Code
;
; 420 pin MAX3088 I/F pin
; -----
; P1.4 DE, Active-Low RE
; P1.3/TXD DI
; P1.2/RXD RO
;-----
#include(420.def) ;SFR equates
tx485 bit p1.4 ;MAX3088 DE, Active-Low RE

```

```

;-----
; Main Program
;-----
org 0000h
ljmp start
;-----
; Timer 0 Interrupt
;-----
org 000bh ; slave didn't respond
clr tr0 ; stop Timer0
mov th0, #00h ; reset Timer0
mov tl0, #00h
setb tx485 ; MAX3088 into transmit mode
pop acc ; get rid of address pushed
pop acc ; to stack on interrupt
pop acc ; get rid of address pushed
pop acc ; to stack on 'call getch'
pop acc ; get slave address
call putbyt ; print slave address
mov dptr, #no_data ; 'no response' string
call puts ; print string
mov a, #low(del) ; return to delay routine
push acc
mov a, #high(del)
push acc
reti
;-----
; Start of Main
;-----
org 0100h
start:
setb tx485 ; MAX3088 in transmit mode
;-----
; Timer 0 Configuration
; used for time-out when no response from addressed slave
;-----
mov tmod, #00h ; 13-bit timer
mov tl0, #00h ; TH0:TL0 = 0000h
mov th0, #00h
setb et0 ; enable timer0 interrupt
setb ea ; enable global interrupts
;-----
; Serial Port 0 Configuration
; used to display slave address and returned databytes
;-----
orl t2con, #30h ; use Timer2 for tx/rx baud rate
mov rcap2h, #0ffh ; RCAP2H:2L = FFFAh
mov rcap2l, #0fah ; 115200 @22.1184 xtal freq
mov th2, #0ffh
mov tl2, #0fah
mov scon, #40h ; serial mode 1
setb t2con.2 ; Timer2 run
;-----
; Serial Port 1 Configuration
; used to tx/rx over RS-485 link
;-----
orl wdcon, #80h ; set baud rate doubler bit
orl ckmod, #10h ; /1 input clk to Timer1
orl tmod, #20h ; Timer1: 8-bit autoreload
mov th1, #0ffh ; fastest
mov tl1, #0ffh ;

```

```

setb tr1 ;timer run
mov scon1, #0c8h ;mode 3, TB8=1
;-----
; RS-485 TX/RX routine
;-----
mov a, #01h ; slave uC address
push acc ; save slave address
tx: pop acc ; get previous slave address
xrl a, #01h ; alternate 00h, 01h
push acc ; save it twice
push acc ;
call putch1 ; send slave addr
setb tr0 ; start Timer 0 for time-out
clr tx485 ; MAX3088 into receive mode
call getch1 ; get slave data byte
mov r5, a ; store first data byte
call getch1 ; get slave data byte
mov r6, a ; store second data byte
clr tr0 ; got both bytes
mov th0, #00h ; reset Timer0
mov tl0, #00h
setb tx485 ; MAX3088 into transmit mode
;-----
; Output results over serial port 0
;-----
pop acc ; get slave addr
call putbyt ; print slave addr
mov a, #' ' ; <space>
call putch
mov a, r5 ; get first data byte
call putbyt ; print data byte
mov a, r6 ; get second data byte
call putbyt ; print data byte
mov a, #0dh ; <CR/LF>
call putch
mov a, #0ah
call putch
;-----
del: mov r0, #080h ; delay before next addr sent
mov r1, #00h
delay: mov r2, #00h
delay1: djnz r2, $
djnz r1, delay1
djnz r0, delay
sjmp tx
no_data: db ' no response',0dh, 0ah, 0
#include(put_code.src)
#include(putcode1.src)
end

```

Code Example (continued): Slave #1, #2 Code

The slave devices are initially configured as receivers, driving the DE, active-low RE pins for their respective transceivers to logic low. The multiprocessor communication mode is used by both slave microcontrollers so that address transmissions over the network can be distinguished from data transmissions. When addressed, the slave device becomes a transmitter and responds to the master by sending two data bytes. Once these bytes have been sent, the slave returns the transceiver to receive mode and begins monitoring the network for its address.

```

;-----
; DS89C430 RS-485 I/F example
; Slave #1, #2 code
;
; 420 pin MAX3088 I/F pin
; -----
; P1.4 DE, Active-Low RE
; P1.3/TXD DI
; P1.2/RXD RO
;-----
#include(420.def) ;SFR equates
tx485 bit p1.4 ;MAX3088 DE, Active-Low RE
;-----
; Main Program
;-----
org 0000h
clr tx485 ; MAX3088 in receive mode
mov r1, #00h ; counter for slave data
;-----
; Serial Port 1 Configuration
; used to tx/rx over RS-485 link
;-----
orl wdcon, #80h ; set baud rate doubler bit
orl ckmod, #10h ; /1 input clk to Timer1
orl tmod, #20h ; Timer1: 8-bit autoreload
mov th1, #0ffh ; fastest
mov tl1, #0ffh ;
setb tr1 ; Timer1 run
mov scon1, #0e0h ; mode 3, multi-uC, TB8=0
mov saddr1, #00h ; slave#1 address
; mov saddr1, #01h ; slave#2 address
mov saden1, #0ffh ; no mask - exact match
;-----
; RS-485 RX/TX routine
;-----
rx:
call getch1 ; waits until address match
mov r0, #20h ; delay to ensure master
djnz r0, $ ; gets into RX mode
setb tx485 ; MAX3088 into transmit mode
mov a, r1 ; get data for transmit
call putch1 ; send 1st byte
inc r1 ; update slave#1 data
; dec r1 ; update slave#2 data
mov a, r1 ; get data for transmit
call putch1 ; send 2nd byte
inc r1 ; update slave#1 data
; dec r1 ; update slave#2 data
clr tx485 ; MAX3088 into receive mode
sjmp rx ; back looking for address
#include(putcode1.src)
end

```

Example Master Output to Serial Port 0

```

...*
...*
00 1213
01 EEED

```

```
00 1415
01 ECEB
00 no response (** opened Slave #1 TXD-DI connection)
01 EAE9
00 1819
01 E8E7
00 1A1B
01 E6E5
00 1C1D
01 E4E3
00 1E1F
01 E2E1
00 2021
01 no response (** opened Slave #2 TXD-DI connection)
00 2223
01 no response (** Slave #2 TXD-DI connection still open)
00 2425
01 DCDB
00 2627
01 DAD9
...*
...*
```

Appendix A: Baud Rate Equations

SERIAL MODE	BAUD CLOCK SOURCE	CLOCK MULTIPLIER SETTING 1X: CD1:0 = 10b 2X: CD1:0 = 00b 2X/4X = 0 4X: CD1:0 = 00b 2X/4X = 1	BAUD CLOCK FREQUENCY AS A FUNCTION OF THE EXTERNAL OSCILLATOR FREQUENCY (OSC) SMOD_x = Doubling Bit TH1 = Timer 1 Reload	
0	System Clock/12 (SM2_x = 0)	1X	OSC/12	
		2X	OSC/6	
		4X	OSC/3	
	System Clock/4 (SM2_x = 1)	1X	OSC/4	
		2X	OSC/2	
		4X	OSC	
1 or 3	Timer 1 (T1MH, T1M = 00b)	1X, 2X, or 4X	$(2^{\text{SMOD}_x} \times \text{OSC})$ [384 × (256 - TH1)]	
	Timer 1 (T1MH, T1M = 01b)	1X	$(2^{\text{SMOD}_x} \times \text{OSC})$ [128 × (256 - TH1)]	
		2X	$(2^{\text{SMOD}_x} \times \text{OSC})$ [64 × (256 - TH1)]	
		4X	$(2^{\text{SMOD}_x} \times \text{OSC})$ [32 × (256 - TH1)]	
	Timer 1 (T1MH, T1M = 1Xb)	1X	$(2^{\text{SMOD}_x} \times \text{OSC})$ [32 × (256 - TH1)]	
		2X	$(2^{\text{SMOD}_x} \times \text{OSC})$ [16 × (256 - TH1)]	
		4X	$(2^{\text{SMOD}_x} \times \text{OSC})$ [8 × (256 - TH1)]	
	Timer 2 TCLK or RCLK = 1)	1X, 2X, or 4X	$\frac{\text{OSC}}{32 \times (65536 - \text{RCAP2H:2L})}$	
	2	Oscillator Clock/64	1X, 2X, or 4X	$\frac{(2^{\text{SMOD}_x} \times \text{OSC})}{64}$

MegaBaud is a trademark of Maxim Integrated Products, Inc.
SPI is a trademark of Motorola, Inc.

Application note 600: www.maxim-ic.com/an600

More Information

For technical support: www.maxim-ic.com/support

For samples: www.maxim-ic.com/samples

Other questions and comments: www.maxim-ic.com/contact

Automatic Updates

Would you like to be automatically notified when new application notes are published in your areas of interest?
[Sign up for EE-Mail™.](#)

Related Parts

DS89C430: [QuickView](#) -- [Full \(PDF\) Data Sheet](#) -- [Free Samples](#)

DS89C450: [QuickView](#) -- [Full \(PDF\) Data Sheet](#) -- [Free Samples](#)

AN600, AN 600, APP600, Appnote600, Appnote 600

Copyright © by Maxim Integrated Products

Additional legal notices: www.maxim-ic.com/legal