



APPLICATION NOTE 572

## Interfacing the MAX195 ADC to the TMS320C3X Evaluation Module

*Abstract: Application note for interfacing the MAX195 and MAX194 analog-to-digital converters (ADCs) to the TMS320C3X evaluation module. Example demo code is given. The demo software configures the TMS320C30 so that FSR1 and DR1 are inputs and CLKR1 and XF1 are outputs. To read the MAX194/MAX195, the software briefly drives the XF1 output low. The demo software polls the serial receiver until a complete frame has been received. Because this is just an interface demo, the software simply writes the received data word to the EVM host data port.*

### Overview

The MAX195 16-bit ADC can be interfaced to Texas Instruments' TMS320C30 DSP by means of its serial interface. The interface uses four wires plus ground. This application note explains how to interface the MAX194/MAX195 Evaluation Kit to the TMS320C3X Evaluation Module.

The example program was assembled using the TMS320C3X/4X COFF Assembler Version 4.50 and the TMS320C3X/4F COFF Linker Version 4.50 (copyright 1987 through 1992 by Texas Instruments Incorporated).

### Interfacing the MAX194/MAX195 EVKIT to the TMS320C3X EVM

Maxim's MAX194/MAX195 Evaluation Kit can be interfaced to Texas Instruments' TMS320C3X Evaluation Module as follows:

1. Set the MAX194/MAX195 EVKIT jumpers according to Table 1.
2. Solder a 2-x-5-pin berg strip into MAX194/MAX195 EVKIT area J3. The PC board is already wired as shown in Table 2.
3. Connect a +5V power supply to the MAX194/MAX195 EVKIT.
4. Connect a 10-pin ribbon cable between the TMS320C3X EVM and the MAX194/MAX195 EVKIT.
5. Run the demo software.

**Table 1. Jumper Settings**

Jumper	Position	Function
JU1	Closed	Connects the MAX195 SCLK to ground
JU3	EXT	TMS320 CLKR1 drives the MAX195 conversion clock.
JU4	CS = GND	Connects the MAX195 Active-Low CS to ground
JU5	QSPI	TMS320 XF1 drives the MAX195 CONV.
JU6	Open	MAX195 reset/calibration command
JU7	UNI or OPEN	Selects unipolar or bipolar transfer function

**Table 2. Ribbon-Cable Signals**

Pin	MAX195	TMS320	Pin	MAX195	TMS320
1	DGND	GND	2	Active-Low EOC	FSR1
3	Not used		4	DOUT	DR1
5	Not used		6	Not used	
7	Not used		8	Active-Low CONV	XF1
9	CONCLK	CLKR1	10	DGND	GND

## How It Works

The demo software (see the program-code listing that follows) configures the TMS320C30 so that FSR1 and DR1 are inputs and CLKR1 and XF1 are outputs. The software uses the XF1 output to initiate a conversion. The XF1 pulse drives the MAX194/MAX195 conversion start input. The CLKR1 output provides the conversion clock to the MAX194/MAX195. Data output from the MAX194/MAX195 is received on the DR1 input. The FSR1 Frame Start signal is driven by the MAX194/MAX195 EOC (End of Conversion) signal, which marks the beginning of the serial frame.

To read the MAX194/MAX195, the software briefly drives the XF1 output low. The demo software polls the serial receiver until a complete frame has been received. Because this is just an interface demo, the software simply writes the received data word to the EVM host data port.

## TMS320C3x/4x COFF Assembler, Version 4.50

### Copyright (c) 1987-1992, Texas Instruments Incorporated

TMS320C30 Serial Port Initialization  
Project: MAX195 EVKIT Interface to TMS320C3X EVM  
Project file = MAX195I

Filename = MAX195I.ASM  
Command file = MAX195I.CMD

Compile with the following commands:

```
asm30 MAX195I -I  
lnk30 MAX195I.CMD
```

Pin Assignments:

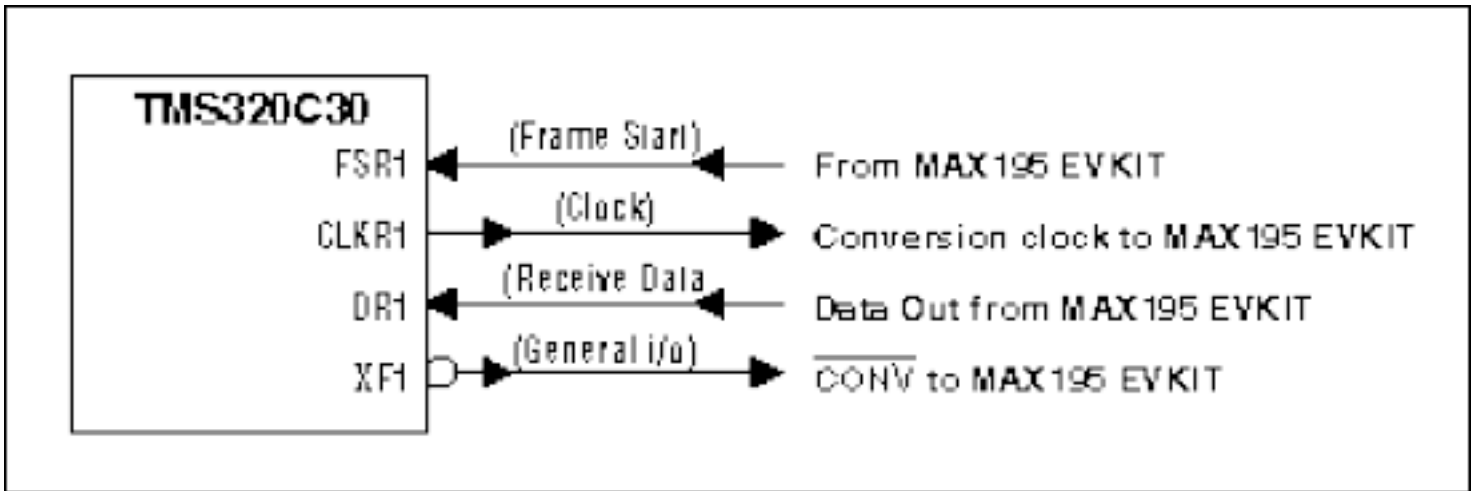

Note: jumper JU8 must be OPEN  
and CS must be tied to GND

Timing Diagram:

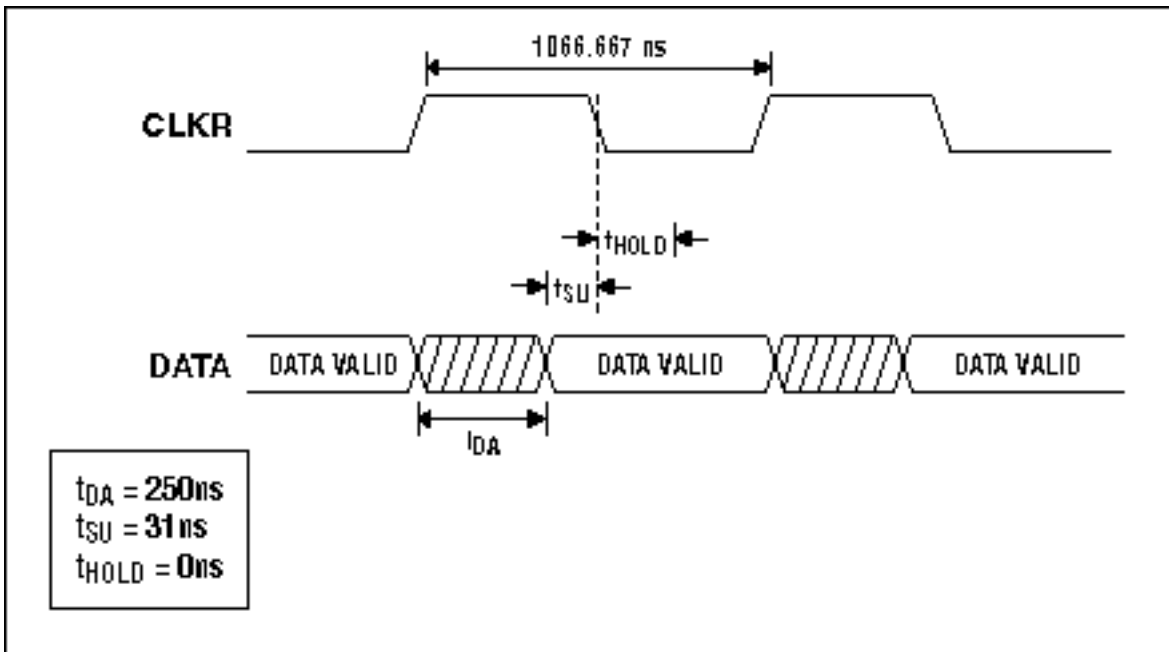

Fastest Clock 1MHz = (1 / 1000 nsec)  
Minimum Receiver Timer Period = 4H

Receive Timer Period = 4 = 0.9375MHz  
(System clock frequency = 30MHz)

Word diagram:

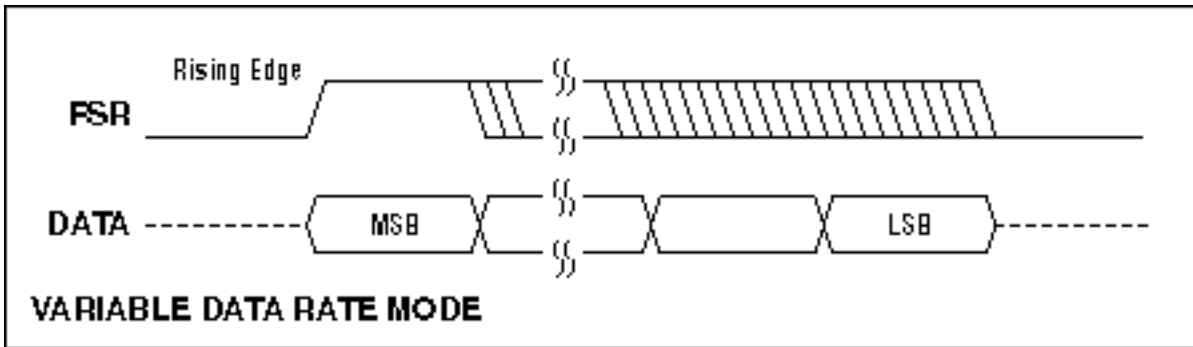

```
.sect    "vectors"
reset .word  init
int0 .word  init
int1 .word  init
int2 .word  init
int3 .word  init
xint0 .word  init
rint0 .word  init
xint1 .word  init
rint1 .word  init
tint0 .word  init
tint1 .word  init
dint .word  init

.data
STCK .word  0809F00H ; initial stack pointer

CTRL .word  0808000H ; peripheral interface base address
HOST_DATA .word  0804000H ; host data port address

IOF_AMASK .set  0000EH ; clear all XF1 bits in IOF register
IOF_SET_XF1 .set  00060H ; make XF1 pin an output; value = 1
IOF_RESET_XF1 .set  00020H ; make XF1 pin an output; value = 0
IOF_INPUT_XF1 .set  00080H ; make XF1 pin an input; read its value

FS_AMASK .set  0F0FFH ; mask for an FS pin
SET_FS .set  00600H ; make FS a high output
RESET_FS .set  00200H ; make FS a low output
GET_FS .set  00800H ; input mask for FS pin

D_AMASK .set  0FF0FH ; mask for a Data pin
SET_D .set  00060H ; make D a high output
RESET_D .set  00020H ; make D a low output
GET_D .set  00080H ; input mask for D pin

CLK_AMASK .set  0FFF0H ; mask for a CLK pin
SET_CLK .set  00006H ; make CLK a high output
RESET_CLK .set  00002H ; make CLK a low output
GET_CLK .set  00008H ; input mask for CLK pin

Serial Port Global Control Register

SerGlob1 .word  08100280H

08000000H: RRESET - reset / enable the receiver
0080H: RCLKSRCE - use internal receive clock (CLKR pin is an output)
```

0200H:

RVAREN - Receiver Variable Data Rate

00100000H: RLEN = 2 bytes (16 bits)

Pin Assignment Register for FSX, CLKX, DX

SerPrTX1 .word 00H

assign CLKX pin to general I/O

make CLKX an input

assign DX pin to general I/O

make DX an input

assign FSX pin to general I/O

make FSX an input

Pin Assignment Register for FSR, CLKR, DR

SerPrTR1 .word 0111H

0001H: assign CLKR pin to serial port clock

0010H: assign DR pin to serial port receive data

0100H: assign FSR pin to serial port frame start

Serial Port Timer Global Control Register

SerTim1 .word 03C0H

XHLD 0=hold transmit timer

XC/P 0=pulse mode

XCLKSRC 0=CLKX pin increments the counter

0040H: RGO=1 -- start the receive timer

0080H: RHLD 1=run receive timer

0100H: RC/P 1=clock (50% duty cycle)

0200H: RCLKSRC 1=use 7.5MHz time base (30MHz system clock/4)

Serial Port Timer Period Register

SerTim1Val .word 040000H

0 H: Transmit Counter Period

4 H: Receive Counter Period

Receive Timer Period = 4 = 0.9375MHz

.text

init

LDI 0,ST ; initialize status register

LDI 0,DP ; point data page pointer into rom

LDI @STCK,SP ; initialize stack pointer

; start with XF1 high

;

LDI IOF,R1 ; get XF1 settings

```

AND IOF_AMASK,R1 ; don't touch XF0 settings
OR IOF_SET_XF1,R1 ; make XF1 output a high value
LDI R1,IOF ; write new XF1 settings

; initialize serial port
;

LDI @CTRL,AR0 ; peripheral interface address
LDI @HOST_DATA,AR1 ; host interface address

LDI @SerTim1Val,R0
STI R0,*+AR0(86) ; serial ch1 timer period

LDI @SerGlob1,R0
STI R0,*+AR0(80) ; serial global register

LDI @SerPrtX1,R0
STI R0,*+AR0(82) ; serial transmit control register

LDI @SerPrtR1,R0
STI R0,*+AR0(83) ; serial receive control register

LDI @SerTim1,R0
STI R0,*+AR0(84) ; serial ch1 timer register

```

XF1 signal is named Active-Low CONV to MAX195 EVKIT

This is how we set XF1:

```

LDI IOF,R1 ; get XF1 settings
AND IOF_AMASK,R1 ; don't touch XF0 settings
OR IOF_SET_XF1,R1 ; make XF1 output a high value
LDI R1,IOF ; write new XF1 settings

```

This is how we clear XF1:

```

LDI IOF,R1 ; get XF1 settings
AND IOF_AMASK,R1 ; don't touch XF0 settings
OR IOF_RESET_XF1,R1 ; make XF1 output a low value
LDI R1,IOF ; write new XF1 settings

```

next\_sample:

generate conversion start pulse

```

LDI IOF,R1 ; get XF1 settings
AND IOF_AMASK,R1 ; don't touch XF0 settings
OR IOF_RESET_XF1,R1 ; make XF1 output a low value
LDI R1,IOF ; write new XF1 settings
AND IOF_AMASK,R1 ; don't touch XF0 settings
OR IOF_SET_XF1,R1 ; make XF1 output a high value
LDI R1,IOF ; write new XF1 settings

```

wait until serial receive is complete

loop

```
LDI *+AR0(80),R2 ; read global control register
AND 01H,R2 ; test the receiver ready bit
BZ loop ; loop until data is received
```

get the received data

```
LDI *+AR0(92),R3 ; copy received data into R3
```

this demo application does no processing --  
it just makes the value available to the  
TMS320C3X EVM's host.

```
STI R3,*+AR1(0) ; send R3 to host
```

```
LDI 100,R0 ; delay
```

```
wait_loop:
```

```
SUBI 1,R0
BNZ wait_loop
```

```
BR @next_sample ; this program runs forever
```

```
.end
```

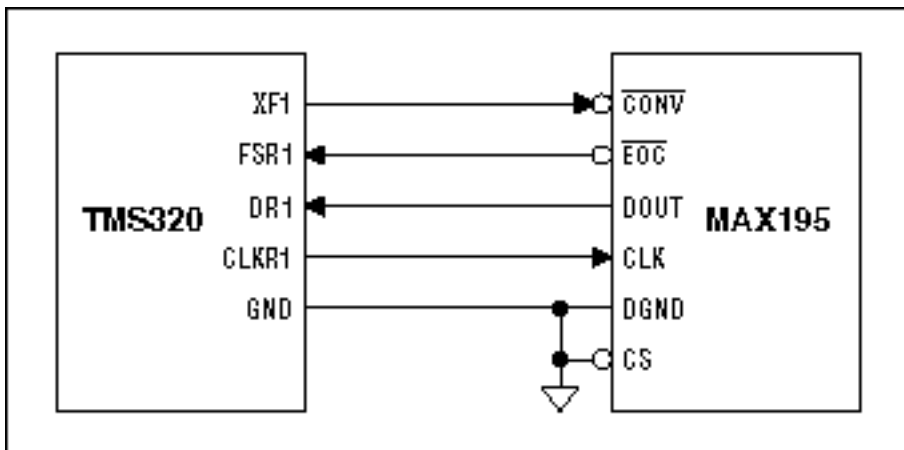

Figure 1. Schematic.

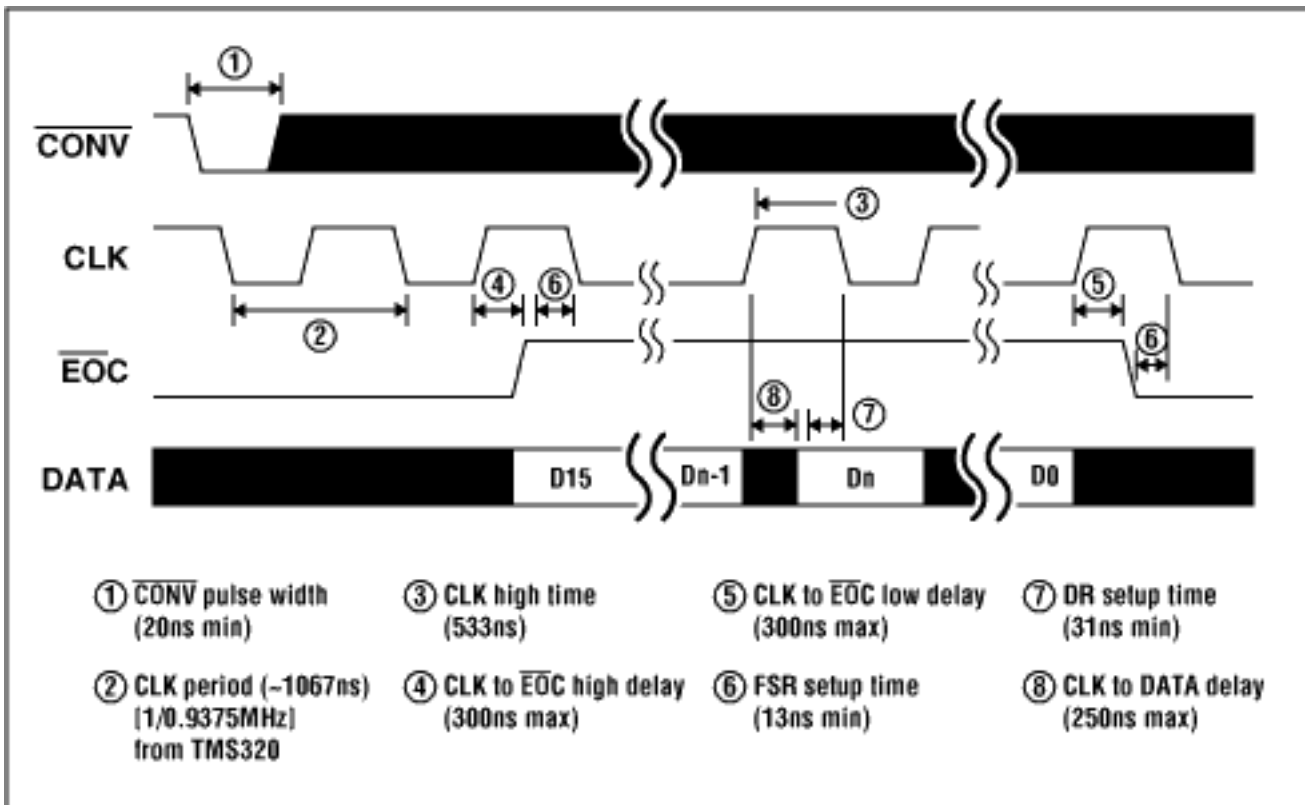

Figure 2. Timing

Application Note 572: <http://www.maxim-ic.com/an572>

### More Information

For technical questions and support: <http://www.maxim-ic.com/support>

For samples: <http://www.maxim-ic.com/samples>

Other questions and comments: <http://www.maxim-ic.com/contact>

### Related Parts

MAX194: [QuickView](#) -- [Full \(PDF\) Data Sheet](#) -- [Free Samples](#)

MAX195: [QuickView](#) -- [Full \(PDF\) Data Sheet](#) -- [Free Samples](#)

AN572, AN 572, APP572, Appnote572, Appnote 572

Copyright © by Maxim Integrated Products

Additional legal notices: <http://www.maxim-ic.com/legal>