



APPLICATION NOTE 530

VCO Tank Design for the MAX2310

Abstract: This application note presents various voltage-controlled oscillator (VCO) designs for popular IF frequencies of 85MHz, 190MHz, and 210MHz. These designs reduce the number of iterations required for optimized results. Analysis can be accomplished with a simple spreadsheet program.

Additional Information:

- [Wireless Product Line Page](#)
- [Quick View Data Sheet for the MAX2306/MAX2308/MAX2309](#)
- [Quick View Data Sheet for the MAX2310/MAX2312/MAX2314/MAX2316](#)
- [Applications Technical Support](#)

Introduction

This application note presents various voltage-controlled oscillator (VCO) designs for popular IF frequencies of 85MHz, 190MHz, and 210MHz. These designs reduce the number of iterations required for optimized results. Analysis can be accomplished with a simple spreadsheet program.

VCO Design

Figure 2 shows the differential tank circuit used for the MAX2310 IF VCO. For analysis purposes, the tank circuit must be reduced to an equivalent simplified model. **Figure 1** depicts the basic VCO model. The frequency of oscillation can be characterized by EQN1:

$$f_{osc} = \frac{1}{2\pi\sqrt{L(C_{int} + C_t)}}$$

EQN1

f_{osc} = frequency of oscillation

L = inductance of the coil in the tank circuit

C_{int} = internal capacitance of the MAX2310 tank port

C_t = total equivalent capacitance of the tank circuit

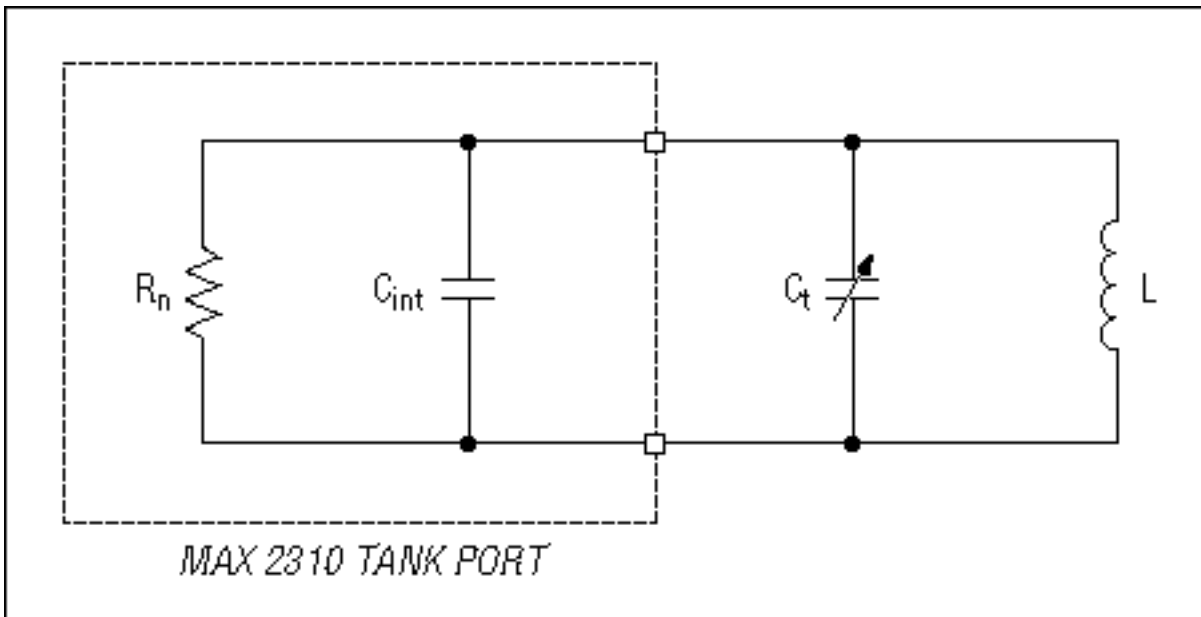

Figure 1. Basic VCO model.

R_n = equivalent negative resistance of the MAX2310 tank port

C_{int} = internal capacitance of the MAX2310 tank port

C_t = total equivalent capacitance of the tank circuit

L = inductance of the coil in the tank circuit

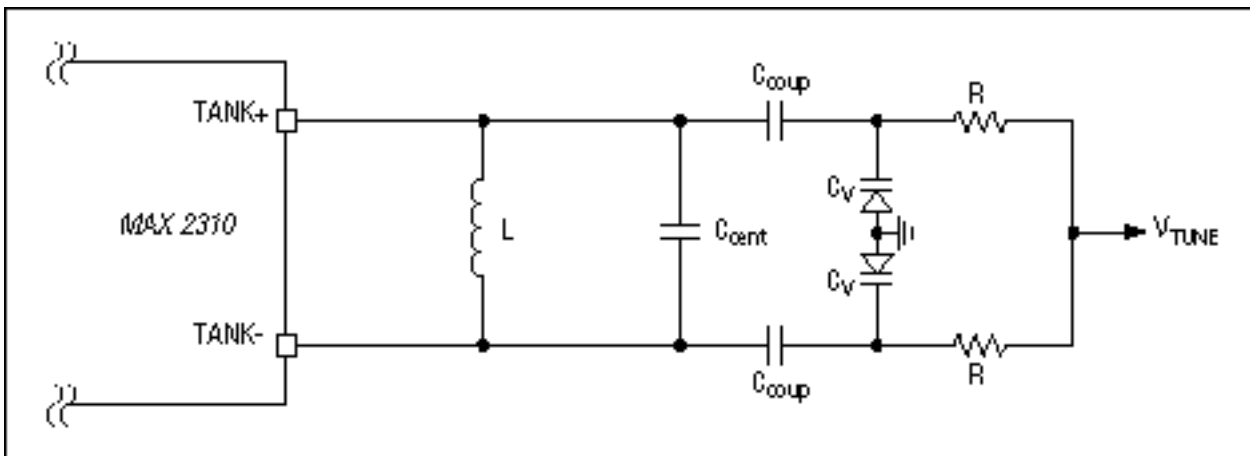

Figure 2. The MAX2310 tank circuit.

Inductor L resonates with the total equivalent capacitance of the tank and the internal capacitance of the oscillator ($C_t + C_{int}$) (see Figure 1). C_{coup} provides DC block and couples the variable capacitance of the varactor diodes to the tank circuit. C_{cent} is used to center the tank's oscillation frequency to a nominal value. It is not required but adds a degree of freedom by allowing one to fine-tune resonance between inductor values. Resistors (R) provide reverse-bias voltage to the varactor diodes via the tune voltage line (V_{tune}). Their value should be chosen large enough so as not to affect loaded-tank Q but small enough so that $4kTBR$ noise is negligible. The resistors' noise voltage gets modulated by K_{VCO} , producing phase noise. Capacitance C_v is the variable tuning component in the tank. The capacitance of varactor diode (C_v) is a function of reverse-bias voltage (see Appendix A for the varactor model). V_{tune} is the tuning voltage from a phase-locked loop (PLL).

Figure 3 shows the lumped C_{stray} VCO model. Parasitic capacitance and inductance plague every RF circuit. In order to predict the frequency of oscillation, the parasitic elements must be taken into account. The circuit in Figure 3 lumps the parasitic elements in one capacitor called C_{stray} . The frequency of oscillation can be characterized by EQN2:

$$f_{osc} = \frac{1}{2\pi \sqrt{L \left[C_{int} + C_{cent} + C_{stray} + \left(\frac{1}{\frac{2}{C_{coup}} + \frac{2}{C_v + C_{vp}}} \right) \right]}}$$

EQN2

- L = inductance of the coil in the tank circuit
- C_{int} = internal capacitance of the MAX2310 tank port
- C_{cent} = tank capacitor used to center oscillation frequency
- C_{stray} = lumped stray capacitance
- C_{coup} = tank capacitor used to couple the varactor to the tank
- C_v = net variable capacitance of the varactor diode (including series inductance)
- C_{vp} = varactor-pad capacitance

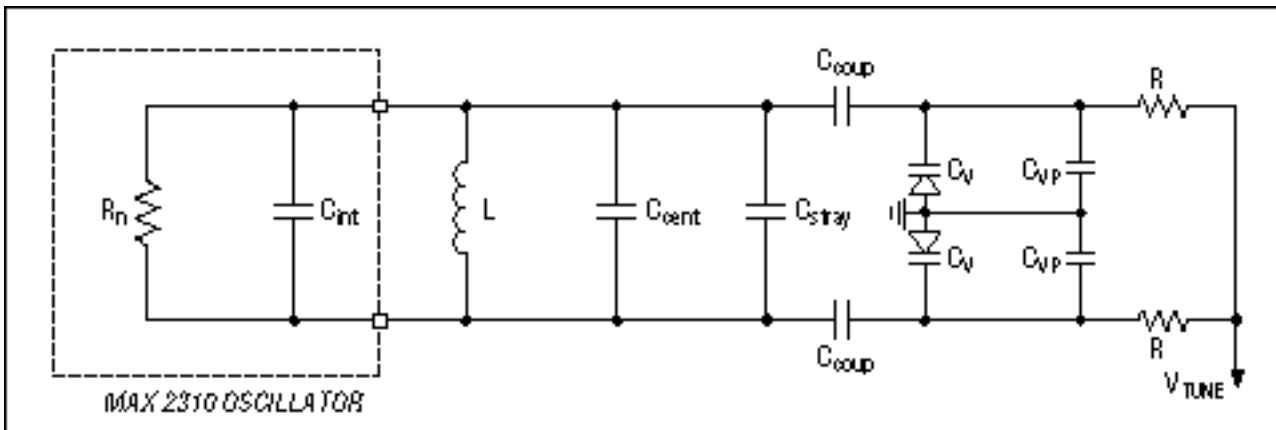

Figure 3. Lumped C_{stray} model.

Figure 4 depicts the detailed VCO model. It takes into account the capacitance of the pads but does not include the effects of series inductance for simplicity. C_{stray} is defined as:

$$C_{stray} = C_L + \frac{C_{LP}}{2} + C_{DIFF}$$

EQN3

- C_L = capacitance of the inductor
- C_{LP} = capacitance of the inductor pads
- C_{DIFF} = capacitance due to parallel traces

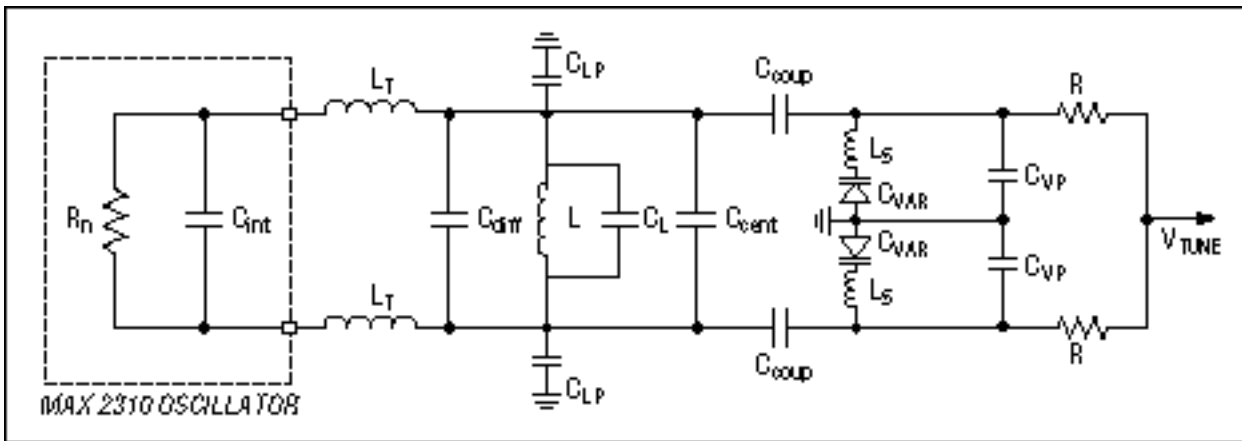

Figure 4. Detailed VCO model.

R_n = equivalent negative resistance of the MAX2310 tank port

C_{int} = internal capacitance of the MAX2310 tank port

L_T = inductance of series trace to the inductor tank circuit

C_{DIFF} = capacitance due to parallel traces

L = inductance of the coil in the tank circuit

C_L = capacitance of the inductor

C_{LP} = capacitance of inductor pads

C_{cent} = tank capacitor used to center oscillation frequency

C_{coup} = tank capacitor used to couple the varactor to the tank

C_{var} = variable capacitance of the varactor diode

C_{vp} = varactor-pad capacitance

L_S = series inductance of the varactor

R = resistance of the varactor reverse-bias resistors

To simplify analysis, inductance L_T is ignored in this design. The effects of L_T are more pronounced at higher frequencies. To mathematically model the shift in frequency due to L_T with the spreadsheets that follow, the value of C_{DIFF} can be increased appropriately. Minimize inductance L_T to prevent undesired series resonance. This can be accomplished by making the traces short.

Tuning Gain

Tuning gain (K_{VCO}) must be minimized for best closed-loop phase noise. Resistors in the loop filter as well as the resistors "R" (Figure 2) will produce broadband noise. Broadband thermal noise ($V_n = \sqrt{4kTB R}$) will modulate the VCO by K_{VCO} , which is measured in MHz/V. There are two ways to minimize K_{VCO} . One is to minimize the frequency range over which the VCO must tune. The second way is to maximize the tuning voltage available. To minimize the frequency range over which the VCO must tune, tight tolerance components must be used, as will be shown. To maximize tuning voltage, a charge pump with a large compliance range is needed. This is usually accomplished by using a larger V_{CC} . The compliance range for the MAX2310 is 0.5V to $V_{CC}-0.5V$. In battery-powered applications, the compliance range is usually fixed by battery voltage or a regulator.

Basic Concept for Trimless Design

VCO design for manufacturability with real-world components will require an error budget analysis. In order to design a VCO to oscillate at a fixed frequency (f_{osc}), the tolerance of the components must be taken into

consideration. Tuning gain (K_{VCO}) must be designed into the VCO to account for these component tolerances. The tighter the component tolerance, the smaller the possible tuning gain, and the lower the closed-loop phase noise. For worst-case error budget design, we will look at three VCO models:

1. Maximum-value components (EQN5)
2. Nominal tank, all components perfect (EQN2)
3. Minimum-value components (EQN4)

All three VCO models must cover the desired nominal frequency. **Figure 5** shows visually how the three designs must converge to provide a manufacturable design solution. Observation of EQN1 and Figure 5 reveal that *minimum-value* components will shift the oscillation frequency *higher* and that *maximum-value* components will shift the oscillation frequency *lower*.

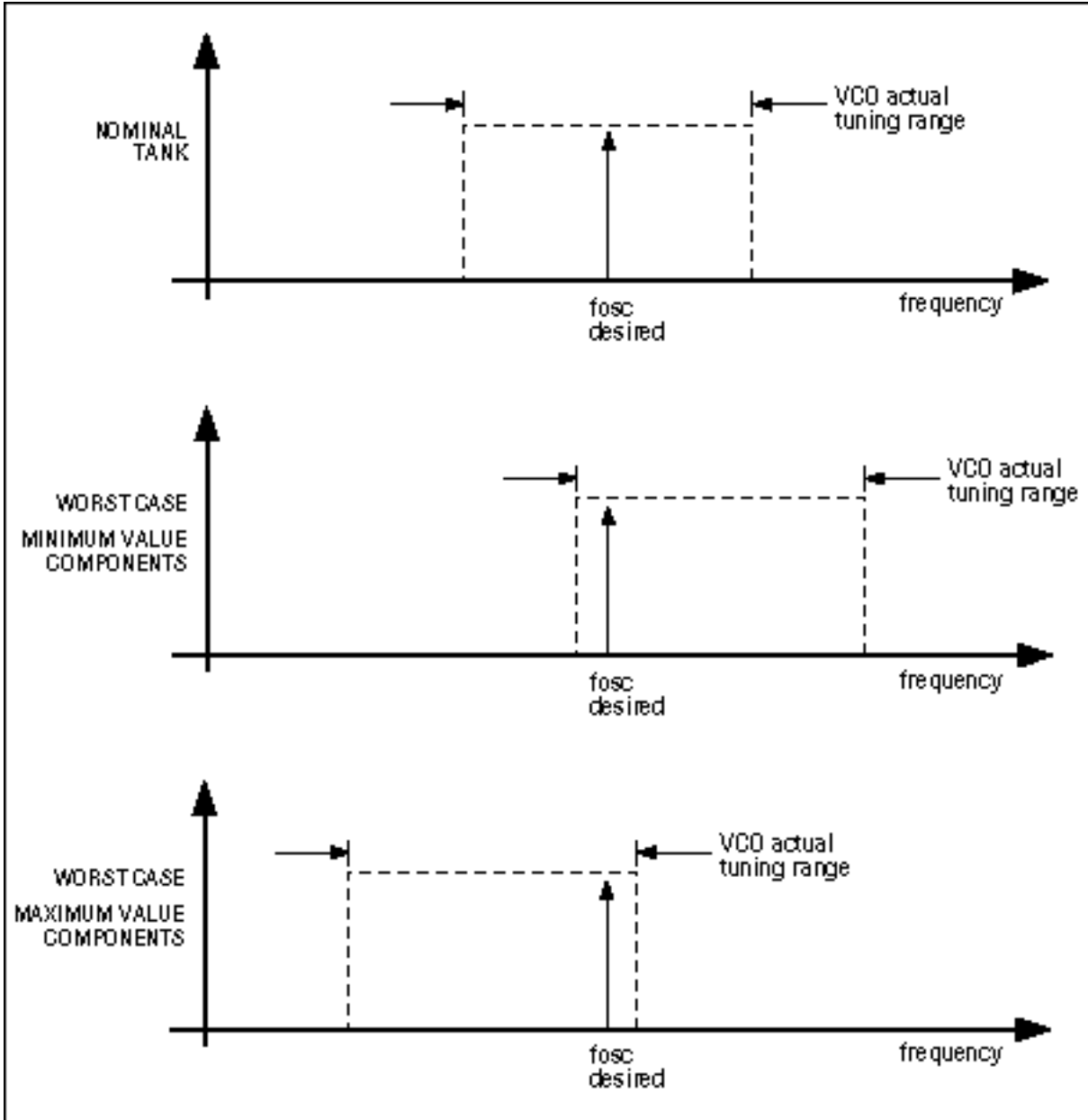

Figure 5. Worst-case and nominal-tank centering.

Minimum tuning range must be used in order to design a tank with the best closed-loop phase noise. Therefore, the nominal tank should be designed to cover the center frequency with overlap to take into account device tolerance. The worst-case high-tune tank and worst-case low-tune tank should tune just to the edge of the desired oscillation frequency. EQN2 can be modified by component tolerance to produce a worst-case high-tune tank EQN4 and a worst-case low-tune tank EQN5.

$$f_{osc} = \frac{1}{2\pi \sqrt{L(1-T_L) \left[C_{INT}(1-T_{C_{INT}}) + C_{CENT}(1-T_{C_{CENT}}) + C_{STRAY} + \frac{1}{\left(\frac{2}{C_{COUP}(1-T_{C_{COUP}})} + \frac{2}{C_V(1-T_{C_V}) + C_{VP}} \right)} \right]}} \quad \text{EQN4}$$

$$f_{osc} = \frac{1}{2\pi \sqrt{L(1+T_L) \left[C_{INT}(1+T_{C_{INT}}) + C_{CENT}(1-T_{C_{CENT}}) + C_{STRAY} + \frac{1}{\left(\frac{2}{C_{COUP}(1+T_{C_{COUP}})} + \frac{2}{C_V(1+T_{C_V}) + C_{VP}} \right)} \right]}} \quad \text{EQN5}$$

T_L = % tolerance of the inductor (L)

$T_{C_{INT}}$ = % tolerance of the capacitor (C_{INT})

$T_{C_{CENT}}$ = % tolerance of the capacitor (C_{CENT})

$T_{C_{COUP}}$ = % tolerance of the capacitor (C_{COUP})

T_{C_V} = % tolerance of the varactor capacitance (C_V)

EQN4 and EQN5 assume that the strays do not have a tolerance.

General Design Procedure

Step 1

Estimate or measure pad capacitance and other strays. The stray capacitance on the MAX2310 Rev C EV kit has been measured with a Boonton Model 72BD capacitance meter. $C_{LP} = 1.13\text{pF}$, $C_{VP} = 0.82\text{pF}$, $C_{DIFF} = 0.036\text{pF}$.

Step 2

Determine the value for capacitance C_{int} . This can be found in the MAX2310/MAX2312/MAX2314/MAX2316 data sheet on Page 5. Typical operating characteristic TANKH PORT 1/S11 vs. FREQUENCY shows the equivalent parallel RC values for several popular LO frequencies. Appendix B includes tables of C_{int} versus frequency for the high- and low-band tank ports. Keep in mind that the LO frequency is twice the IF frequency.

Example:

For an IF frequency of 210MHz (high-band tank), the LO will operate at 420MHz. From Appendix B, Table 5, $C_{int} = 0.959\text{pF}$.

Step 3

Choose an inductor. A good starting point is using the geometric mean. This will be an iterative process.

$$L = \sqrt{\frac{1}{(2\pi f_{osc})^2 \times 1 \times 10^{-21}}}$$

EQN6

This equation assumes L in (nH) and C in (pF) ($1 \times 10^{-9} \times 1 \times 10^{-12} = 1 \times 10^{-21}$). L = 11.98nH for a $f_{osc} = 420\text{MHz}$. This implies a total tank capacitance C = 11.98pF. An appropriate initial choice for an inductor would be 12nH Coilcraft 0805CS-12NXGBC 2% tolerance.

When choosing an inductor with finite step sizes, the following formula EQN6.1 will be useful. The total product LC should be constant for a fixed oscillation frequency f_{osc} .

$$LC = \frac{1}{(2\pi f_{osc})^2 \times 1 \times 10^{-21}}$$

EQN6.1

LC = 143.5 for a $f_{osc} = 420\text{MHz}$. The trial-and-error process with the spreadsheet in Table 3 yielded an inductor value of 18nH 2% with a total tank capacitance of 7.9221pF. The LC product for the tank in **Figure 8** is 142.59, close enough to the desired LC product of 143.5. One can see this is a useful relationship to have on hand. For best phase noise, choose a high-Q inductor like the Coilcraft 0805CS series. Alternatively, a micro-strip inductor can be used if the tolerance and Q can be controlled reasonably.

Step 4

Determine the PLL compliance range. This is the range over which the VCO tuning voltage (V_{tune}) will be designed to work. For the MAX2310, the compliance range is 0.5V to $V_{cc}-0.5\text{V}$. For a $V_{cc} = 2.7\text{V}$, this would set the compliance range to 0.5 to 2.2V. The charge-pump output will set this limit. The voltage swing on the tank is 1Vp-p centered at 1.6VDC. Even with large values for C_{coup} , the varactor diodes will not be forward-biased. This is a condition to be avoided, as the diode will rectify the AC signal on the tank pins, producing undesirable spurious response and loss of lock in a closed-loop PLL.

Step 5

Choose a varactor. Look for a varactor with good tolerance over your specified compliance range. Keep the series resistance small. For a figure of merit, check that the self-resonant frequency of the varactor is above the desired operating point. Look at the $C_v(2.5\text{V})/C_v(0.5\text{V})$ ratio at your compliance-range voltage. If the coupling capacitors C_{coup} were chosen large, then the maximum tuning range can be calculated using EQN2. Smaller values of capacitor C_{coup} will reduce this effective frequency tuning range. When choosing a varactor, it should have a tolerance specified at your given compliance-range mid and end points. Select a hyperabrupt varactor such as the Alpha SMV1763-079 for linear tuning response. Take the value for total tank capacitance, and use that for C_{jo} of the varactor. Remember, C_{coup} will reduce the net capacitance coupled to the tank.

Step 6

Pick a value for C_{coup} . Large values of C_{coup} will increase tuning range by coupling more of the varactor into the tank at the expense of decreasing tank-loaded Q. Smaller values of C_{coup} will increase the effective Q of the

coupled varactor and loaded Q of the tank at the expense of reducing tuning range. Typically this will be chosen as small as possible, while still getting the desired tuning range. Another benefit of choosing C_{coup} small is that it reduces the voltage swing across the varactor diode. This will help thwart forward-biasing the varactor.

Step 7

Pick a value for C_{cent} , usually around 2pF or greater for tolerance purposes. Use C_{cent} to center the VCO's nominal frequency.

Step 8

Iterate with the spreadsheet.

MAX2310 VCO Tank Designs for IF Frequencies of 85MHz, 190MHz, and 210MHz

The following spreadsheets show designs for several popular IF frequencies for the MAX2310. Keep in mind that the LO oscillates at twice the desired IF frequency.

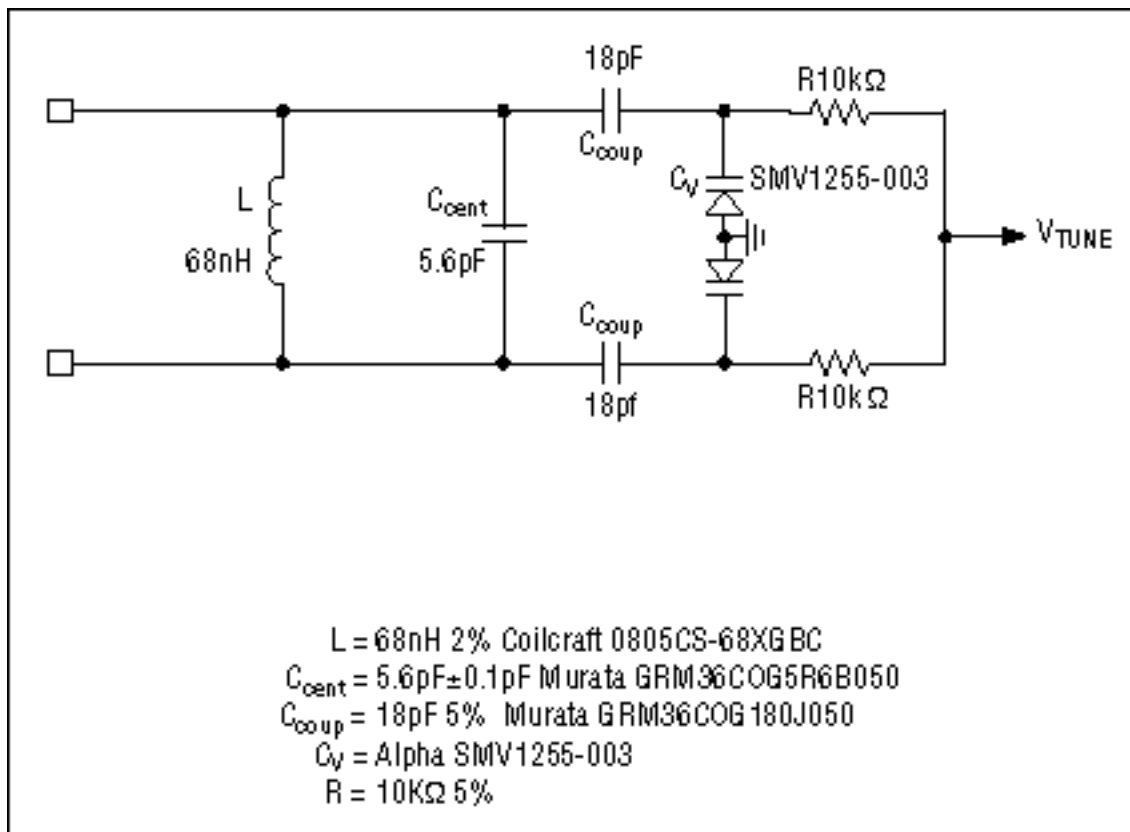

Figure 6. 85MHz low-band IF tank schematic.

Table 1. 85MHz Low-Band IF Tank Design

Light grey indicates calculated values.

Darker grey indicates user input.

MAX2310 Low-Band Tank Design and Tuning Range

Total Tank Capacitance vs. V tune

V tune	Total C	Ct (Nominal)	Ct (Low)	Ct (High)
0.5V	Ct high	14.1766pF	13.3590pF	14.9459pF
1.375V	Ct mid	12.8267pF	11.7445pF	13.7620pF
2.2V	Ct low	11.4646pF	10.3049pF	12.4534pF

Tank Components

Tank Components		Tolerance		
C coup	18pF	0.9pF	5%	
C cent	5.6pF	0.1pF	2%	
C stray	0.70pF			
L	68nH	2.00%		
C int	0.902pF	10.00%		

Parasitics and Pads (C stray)

Due to Q	C L	0.1pF
Ind. pad	C Lp	1.13pF
Due to	C diff	0.036pF
Var. pad	C vp	0.82pF

Varactor Specs

Alpha SMV1255-003

Alpha SMV1255-003		Varactor Tolerance	
Cjo	82pF		
Vj	17V	0.5V	19.00%
M	14	1.5V	29.00%
Cp	0pF	2.5V	35.00%
Rs	1Ω	Reactance	
Ls	1.7nH	X Ls	1.82
Freq	170.00MHz		

Nominal Varactor		X c	Net Cap
Cv high	54.64697pF	-17.1319	61.12581pF
Cv mid	27.60043pF	-33.92	29.16154pF
Cv low	14.92387pF	-62.7321	15.36874pF

Negative Tol Varactor (Low Capacitance)			
Cv high	44.26404pF	-21.1505	48.42117pF
Cv mid	19.59631pF	-47.7746	20.37056pF
Cv low	9.700518pF	-96.5109	9.886531pF

Positive Tol Varactor (High Capacitance)			
Cv high	65.02989pF	-14.3965	74.41601pF
Cv mid	35.60456pF	-26.2945	38.24572pF
Cv low	20.14723pF	-46.4682	20.96654pF

	Nominal LO (Nom) Range	Low Tol IF (High) Range	Nominal IF (Nom) Range	High Tol IF (Low) Range
F low	162.10MHz	84.34MHz	81.05MHz	78.16MHz
F mid	170.42MHz	89.95MHz	85.21MHz	81.45MHz
F high	180.25MHz	96.03MHz	90.13MHz	85.62MHz
BW	18.16MHz	11.69MHz	9.08MHz	7.46MHz
% BW	10.65%	12.99%	10.65%	9.16%

Nominal IF Frequency	85.00MHz
----------------------	----------

Design Constraints			
Condition for bold number	<IF	=IF	> IF
Delta	0.66	-0.21	0.62
Test	pass	pass	pass
Raise or lower cent freq by		-0.21	MHz
Inc or dec BW		-1.28	MHz
Cent adj for min BW		84.98	MHz

K vco	10.68MHz/V
-------	------------

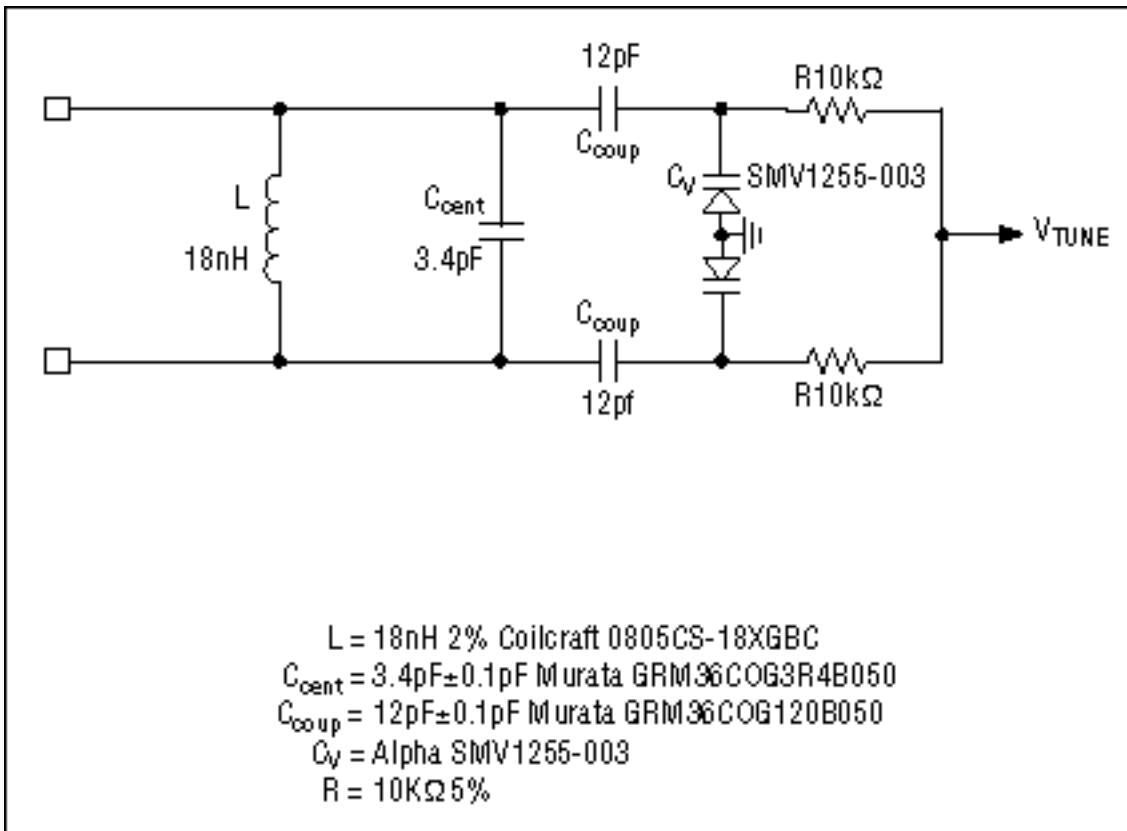

Figure 7. 190MHz high-band IF tank schematic.

Table 2. 190MHz High-Band IF Tank Design

Light grey indicates calculated values.

Darker grey indicates user input.

MAX2310 High-Band Tank Design and Tuning Range

Total Tank Capacitance vs. V tune

V tune	Total C	Ct (Nominal)	Ct (Low)	Ct (High)
0.5V	Ct high	10.4968pF	10.0249pF	10.9126pF
1.375V	Ct mid	9.6292pF	8.8913pF	10.2124pF
2.2V	Ct low	8.6762pF	7.7872pF	9.3717pF

Tank Components	Tolerance		
C coup	12pF	0.1pF	1%
C cent	3.4pF	0.1pF	3%
C stray	0.70pF		
L	18nH	2.00%	
C int	0.954pF	10.00%	

Parasitics and Pads (C stray)

Due to Q	C L	0.01pF
Ind. pad	C Lp	1.13pF
Due to	C diff	0.036pF

Var. pad	C vp	0.82pF
----------	------	--------

Varactor Specs

Alpha SMV1255-003

Cjo	82pF	Varactor Tolerance	
Vj	17V	0.5V	19.00%
M	14	1.5V	29.00%
Cp	0pF	2.5V	35.00%
Rs	1Ω	Reactance	
Ls	1.7nH	X Ls	4.06
Freq	380.00MHz		

Nominal Varactor		X c	Net Cap
Cv high	54.64697pF	-7.66426	116.1695pF
Cv mid	27.60043pF	-15.1747	37.67876pF
Cv low	14.92387pF	-28.0643	17.44727pF

Negative Tol Varactor (Low Capacitance)

Cv high	44.26404pF	-9.46205	77.51615pF
Cv mid	19.59631pF	-21.3728	24.19031pF
Cv low	9.700518pF	-43.1759	10.70708pF

Positive Tol Varactor (High Capacitance)

Cv high	65.02989pF	-6.44056	175.8588pF
Cv mid	35.60456pF	-11.7633	54.36221pF
Cv low	20.14723pF	-20.7884	25.03539pF

	Nominal LO (Nom) Range	Low Tol IF (High) Range	Nominal IF (Nom) Range	High Tol IF (Low) Range
F low	366.15MHz	189.23MHz	183.07MHz	177.78MHz
F mid	382.29MHz	200.94MHz	191.14MHz	183.78MHz
F high	402.74MHz	214.71MHz	201.37MHz	191.84MHz
BW	36.59MHz	25.47MHz	18.29MHz	14.06MHz
% BW	9.57%	12.68%	9.57%	7.65%

Nominal IF Frequency	190MHz
----------------------	--------

Design Constraints			
Condition for bold number	< IF	= IF	> IF
Delta	0.77	-1.14	1.84
Test	pass	pass	pass
Raise or lower cent freq by		-1.14	MHz

Inc or dec BW	-2.61	MHz
Cent adj for min BW	190.54	MHz

K vco 21.52MHz/V

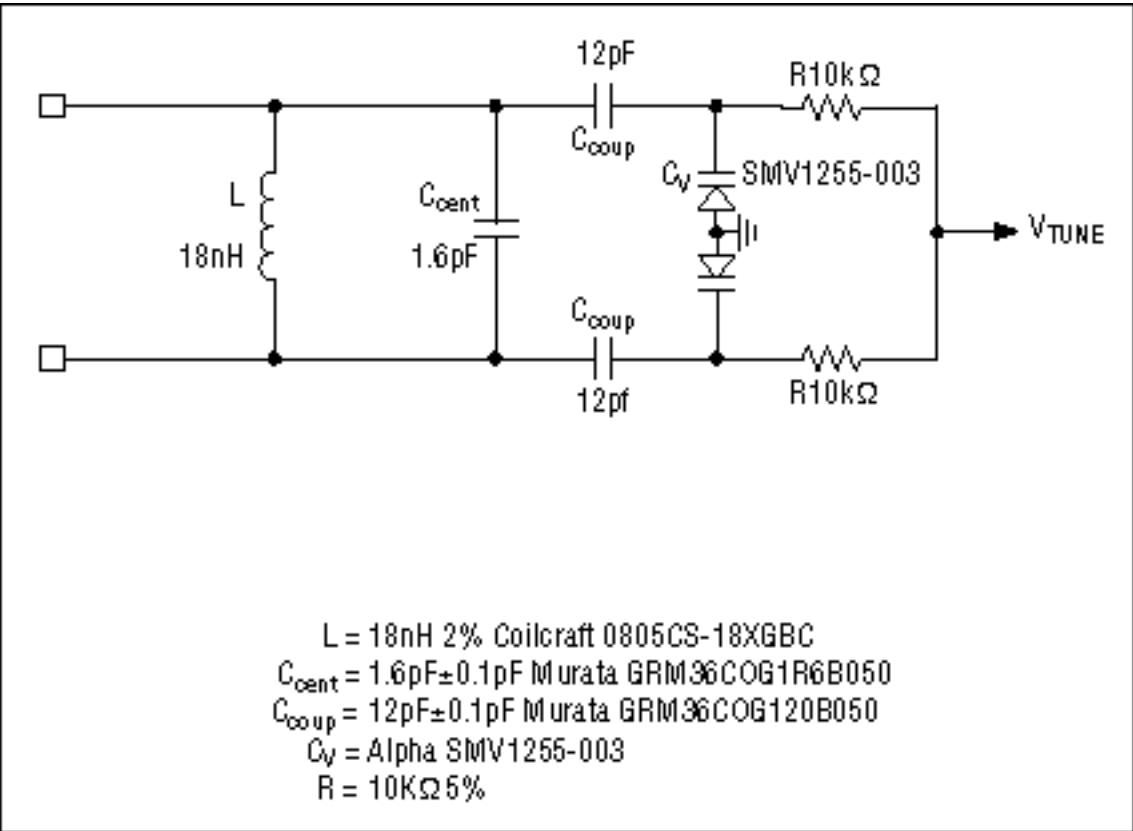

Figure 8. 210MHz high-band IF tank schematic.

Table 3. 210MHz High-Band IF Tank Design

Light grey indicates calculated values.

Darker grey indicates user input.

MAX2310 High-Band Tank Design and Tuning Range

Total Tank Capacitance vs. V tune

V tune	Total C	Ct (Nominal)	Ct (Low)	Ct (High)
0.5V	Ct high	8.8304pF	8.1465pF	9.4877pF
1.35V	Ct mid	7.9221pF	7.0421pF	8.6970pF
2.2V	Ct low	6.9334pF	5.9607pF	7.7653pF

Tank Components	Tolerance		
C coup	12pF	0.6pF	5%
C cent	1.6pF	0.1pF	6%
C stray	0.70pF		
L	18nH	2.00%	
C int	0.959pF	10.00%	

Parasitics and Pads (C stray)		
Due to Q	C L	0.1pF
Ind. pad	C Lp	1.13pF
Due to	C diff	0.036pF
Var. pad	C vp	0.82pF

Varactor Specs			
Alpha SMV1255-003			
Cjo	82pF	Varactor Tolerance	
Vj	17V	0.5V	19.00%
M	14	1.5V	29.00%
Cp	0pF	2.5V	35.00%
Rs	1Ω	Reactance	
Ls	1.7nH	X Ls	4.49
Freq	420.00MHz		

Nominal Varactor		X c	Net Cap
Cv high	54.64697pF	-6.93433	154.787pF
Cv mid	27.60043pF	-13.7295	40.99616pF
Cv low	14.92387pF	-25.3916	18.12647pF

Negative Tol Varactor (Low Capacitance)			
Cv high	44.26404pF	-8.56091	92.99806pF
Cv mid	19.59631pF	-19.3373	25.51591pF
Cv low	9.700518pF	-39.0639	10.95908pF

Positive Tol Varactor (High Capacitance)			
Cv high	65.02989pF	-5.82717	282.5852pF
Cv mid	35.60456pF	-10.643	61.54791pF
Cv low	20.14723pF	-18.8086	26.45795pF

	Nominal LO (Nom) Range	Low Tol IF (High) Range	Nominal IF (Nom) Range	High Tol IF (Low) Range
F low	399.20MHz	209.92MHz	199.60MHz	190.67MHz
F mid	421.47MHz	225.78MHz	210.73MHz	199.14MHz
F high	450.52MHz	245.41MHz	225.26MHz	210.75MHz
BW	51.31MHz	35.49MHz	25.66MHz	20.09MHz
% BW	12.18%	15.72%	12.18%	10.09%

Nominal IF Frequency	210MHz
----------------------	--------

Design Constraints			
condition for bold number	< IF	= IF	> IF
Delta	0.08	-0.73	0.75
Test	pass	pass	pass
Raise or lower cent freq by		-0.73	MHz
Inc or dec BW		-0.83	MHz
Cent adj for min BW		210.34	MHz

K vco	30.18MHz/V
-------	------------

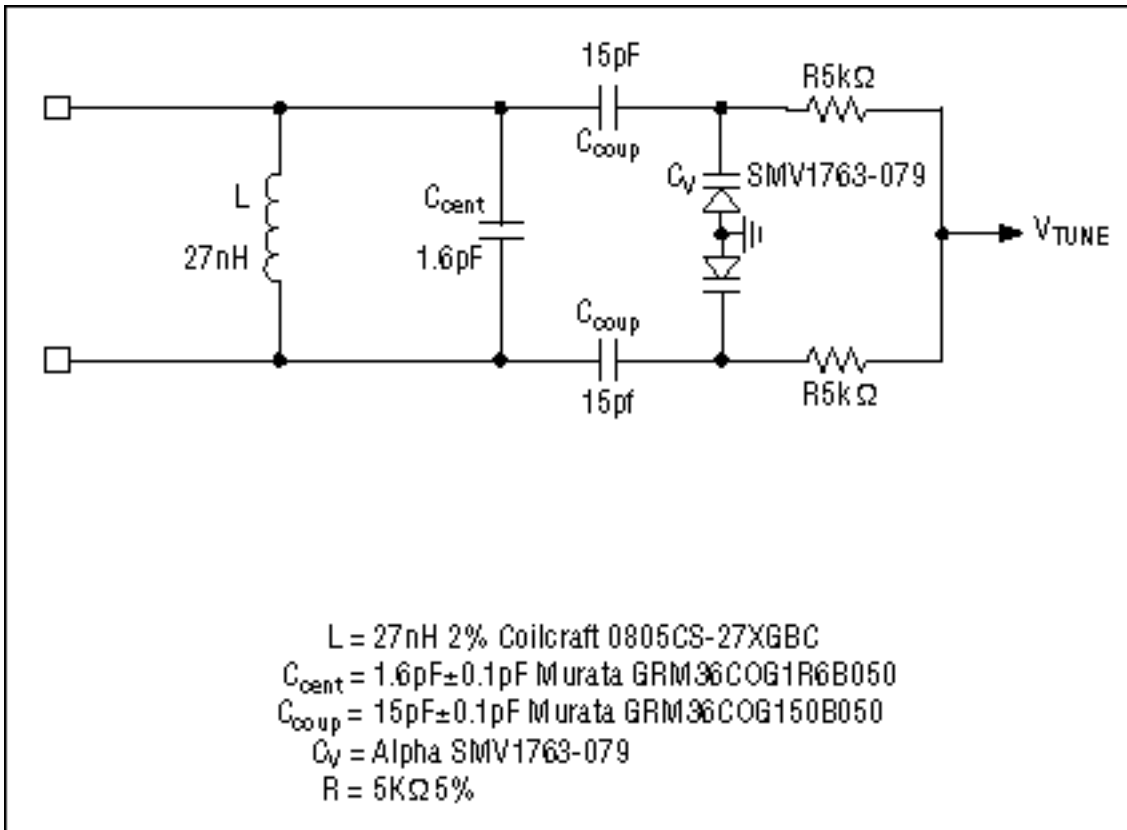

Figure 9. High-Q 210MHz high-band IF tank schematic.

Table 4. High-Q 210MHz High-Band IF Tank Design

Light grey indicates calculated values.

Darker grey indicates user input.

MAX2310 High-Band Tank Design and Tuning Range

Total Tank Capacitance vs. V tune

V tune	Total C	Ct (Nominal)	Ct (Low)	Ct (High)
0.5V	Ct high	5.8856	5.5289	6.2425
1.375V	Ct mid	5.2487	4.9113	5.5858
2.2V	Ct low	4.8371	4.5156	5.1581

Tank Components

C coup	15pF	0.75pF	5%
C cent	1.6pF	0.1pF	6%
C stray	0.77pF		
L	27	2.00%	
C int	0.959	10.00%	

Parasitics and Pads (C stray)

Due to Q	C L	0.17pF
Ind. pad	C Lp	1.13pF
Due to	C diff	0.036pF
Var. pad	C vp	0.82pF

Varactor Specs

Alpha SMV1763-079

Cjo	8.2pF	Varactor Tolerance	
Vj	15V	0.5V	7.50%
M	9.5	1.5V	9.50%
Cp	0.67pF	2.5V	11.50%
Rs	0.5Ω	Reactance	
Ls	0.8nH	X Ls	2.11
Freq	420.00MHz		

Nominal Varactor		X c	Net Cap
Cv high	6.67523pF	-56.7681	6.933064pF
Cv mid	4.23417pF	-89.4958	4.336464pF
Cv low	2.904398pF	-130.471	2.952167pF

Negative Tol Varactor (Low Capacitance)

Cv high	6.174588pF	-61.3709	6.39456pF
Cv mid	3.831924pF	-98.8904	3.915514pF
Cv low	2.570392pF	-147.425	2.607736pF

Positive Tol Varactor (High Capacitance)

Cv high	7.175873pF	-52.8076	7.474698pF
Cv mid	4.636416pF	-81.7313	4.759352pF
Cv low	3.238404pF	-117.015	3.297904pF

	Nominal LO (Nom) Range	Low Tol IF (High) Range	Nominal IF (Nom) Range	High Tol IF (Low) Range
F low	399.25MHz	208.05MHz	199.62MHz	191.92MHz
F mid	422.78MHz	220.75MHz	211.39MHz	202.89MHz
F high	440.40MHz	230.22MHz	220.20MHz	211.14MHz

BW	41.15MHz	22.16MHz	20.58MHz	19.21MHz
% BW	9.73%	10.04%	9.73%	9.47%

Nominal IF Frequency	210MHz
----------------------	--------

Design Constraints

Condition for bold number	< IF	= IF	> IF
Delta	1.95	-1.39	1.14
Test	pass	pass	pass
Raise or lower cent freq by		-1.39	MHz
Inc or dec BW		-3.08	MHz
Cent adj for min BW		209.60	MHz

K vco	24.21MHz/V
-------	------------

Appendix A

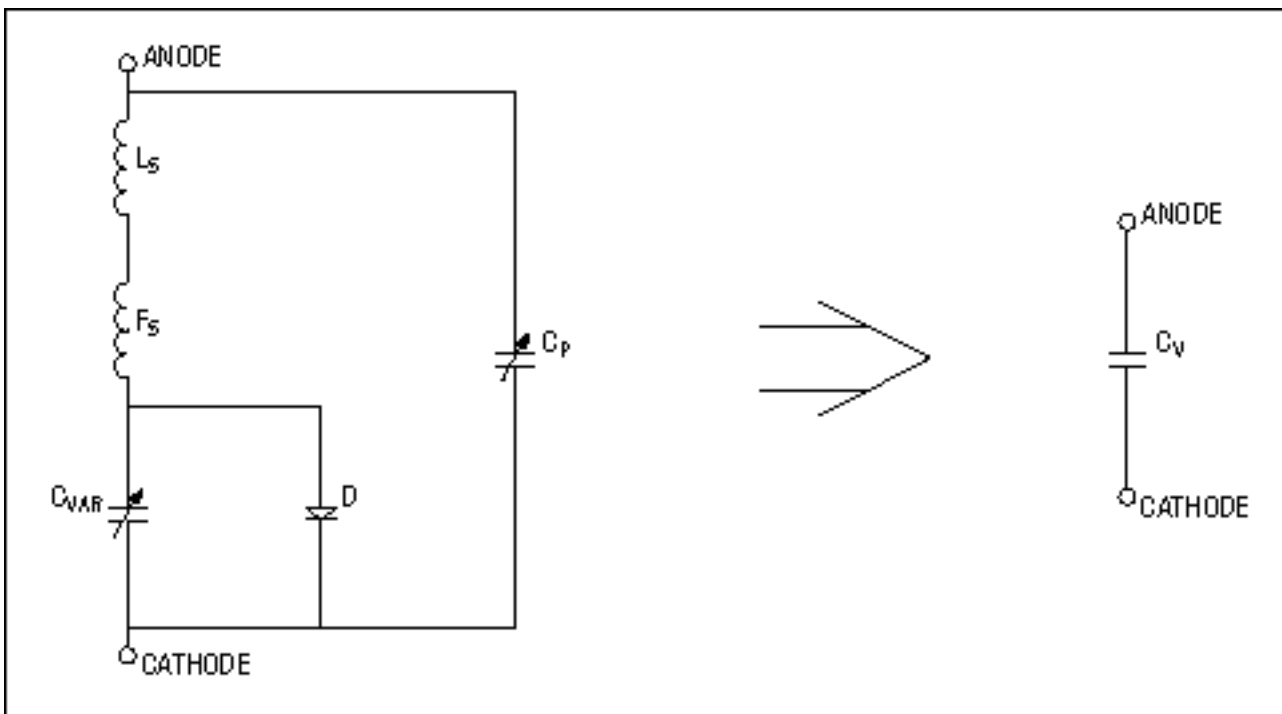

Figure 10. Varactor model.

Alpha Application Note AN1004 has additional information on varactor models. Varactor capacitance is defined in EQN7:

$$C_{VAR} = \frac{C_0}{\left(1 + \frac{V_R}{V_J}\right)^M} + C_P$$

EQN7

Alpha SMV1255-003

$$C_{j0} = 82 \text{ pF}$$

$$V_j = 17 \text{ V}$$

$$M = 14$$

$$C_p = 0$$

$$R_s = 1 \Omega$$

$$L_s = 1.7 \text{ nH}$$

Alpha SMV1763-079

$$C_{j0} = 8.2 \text{ pF}$$

$$V_j = 15 \text{ V}$$

$$M = 9.5$$

$$C_p = 0.67$$

$$R_s = 0.5 \Omega$$

$$L_s = 0.8 \text{ nH}$$

The series inductance of the varactor is taken into account by backing out the inductive reactance and calculating a new effective capacitance C_v :

$$C_v = -\frac{1}{2\pi f(X_{CVAR} + X_{LS})}$$

EQN8

Appendix B

Table 5. C_{int} vs. Frequency for the MAX2310 High-Band Tank

Frequency (MHz)	C_{int} (pF)	Frequency (MHz) (cont.)	C_{int} (pF) (cont.)
100	0.708	360	0.949
110	0.759	370	0.955
120	0.800	380	0.954
130	0.809	390	0.954
140	0.839	400	0.954
150	0.822	410	0.955
160	0.860	420	0.959
170	0.869	430	0.956
180	0.880	440	0.959
190	0.905	450	0.964
200	0.917	460	0.962
210	0.920	470	0.963
220	0.926	480	0.963
230	0.924	490	0.960
240	0.928	500	0.964
250	0.935	510	0.965
260	0.932	520	0.968
270	0.931	530	0.966
280	0.933	540	0.968
290	0.927	550	0.967
300	0.930	560	0.974
310	0.933	570	0.977
320	0.943	580	0.976
330	0.944	590	0.984
340	0.945	600	0.982
350	0.956	-	-

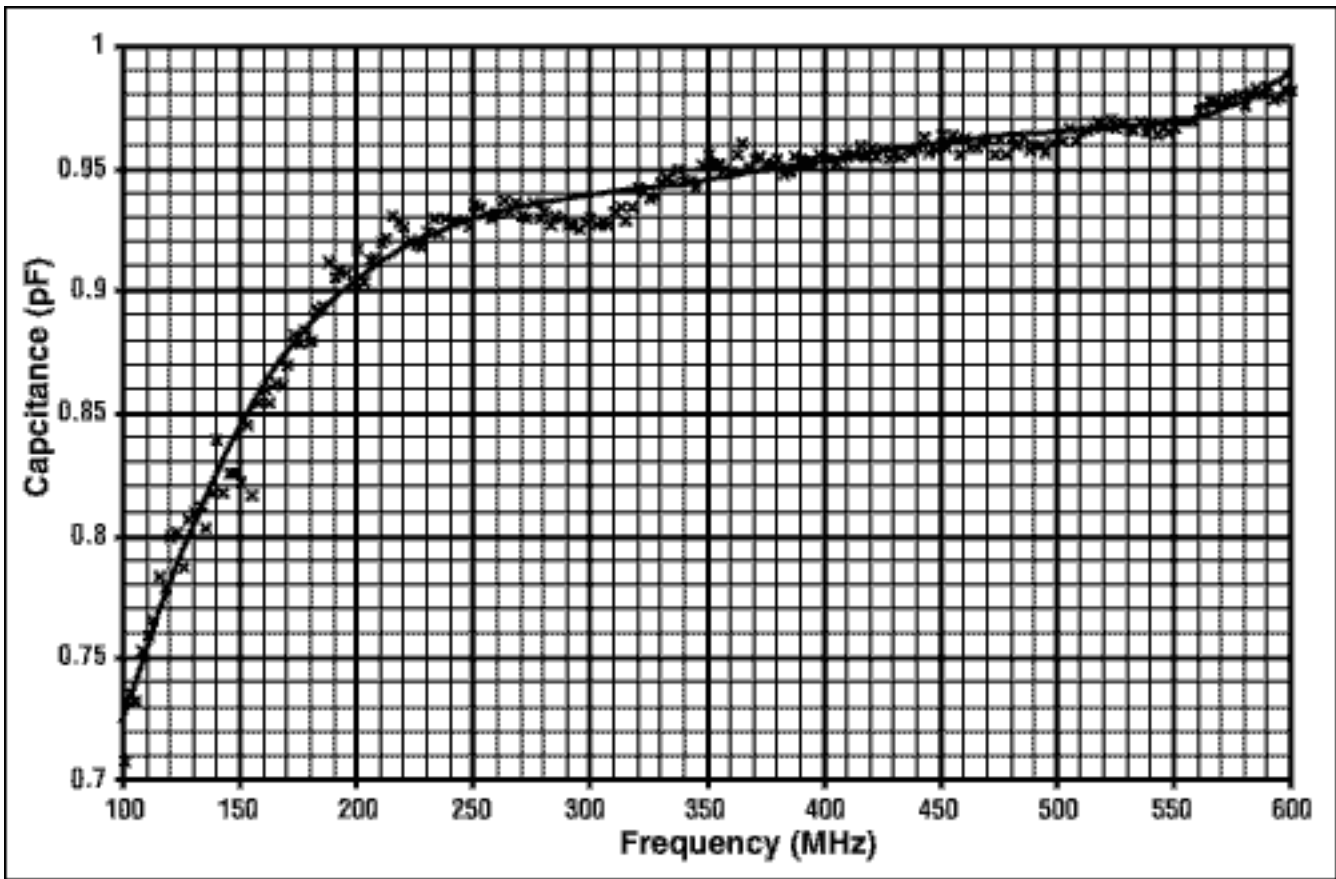

Figure 11. C_{int} vs. frequency for the MAX2310 high-band tank (sixth-order polynomial curve fit)

Table 6. C_{int} vs. Frequency for the MAX2310 Low-Band Tank

Frequency (MHz)	C _{int} (pF)	Frequency (MHz) (cont.)	C _{int} (pF) (cont.)
100	0.550	360	1.001
110	0.649	370	0.982
120	0.701	380	0.992
130	0.764	390	1.001
140	0.762	400	0.985
150	0.851	410	0.980
160	0.838	420	0.986
170	0.902	430	0.992
180	0.876	440	0.994
190	0.907	450	1.001
200	0.913	460	1.003
210	0.919	470	1.007
220	0.945	480	0.992
230	0.952	490	1.010
240	0.965	500	1.004
250	0.951	510	1.011
260	0.954	520	1.022
270	0.974	530	1.019
280	0.980	540	1.044
290	0.973	550	1.026
300	0.982	560	1.041
310	0.970	570	1.038
320	0.982	580	1.032
330	0.991	590	1.036
340	0.993	600	1.025
350	0.991	-	-

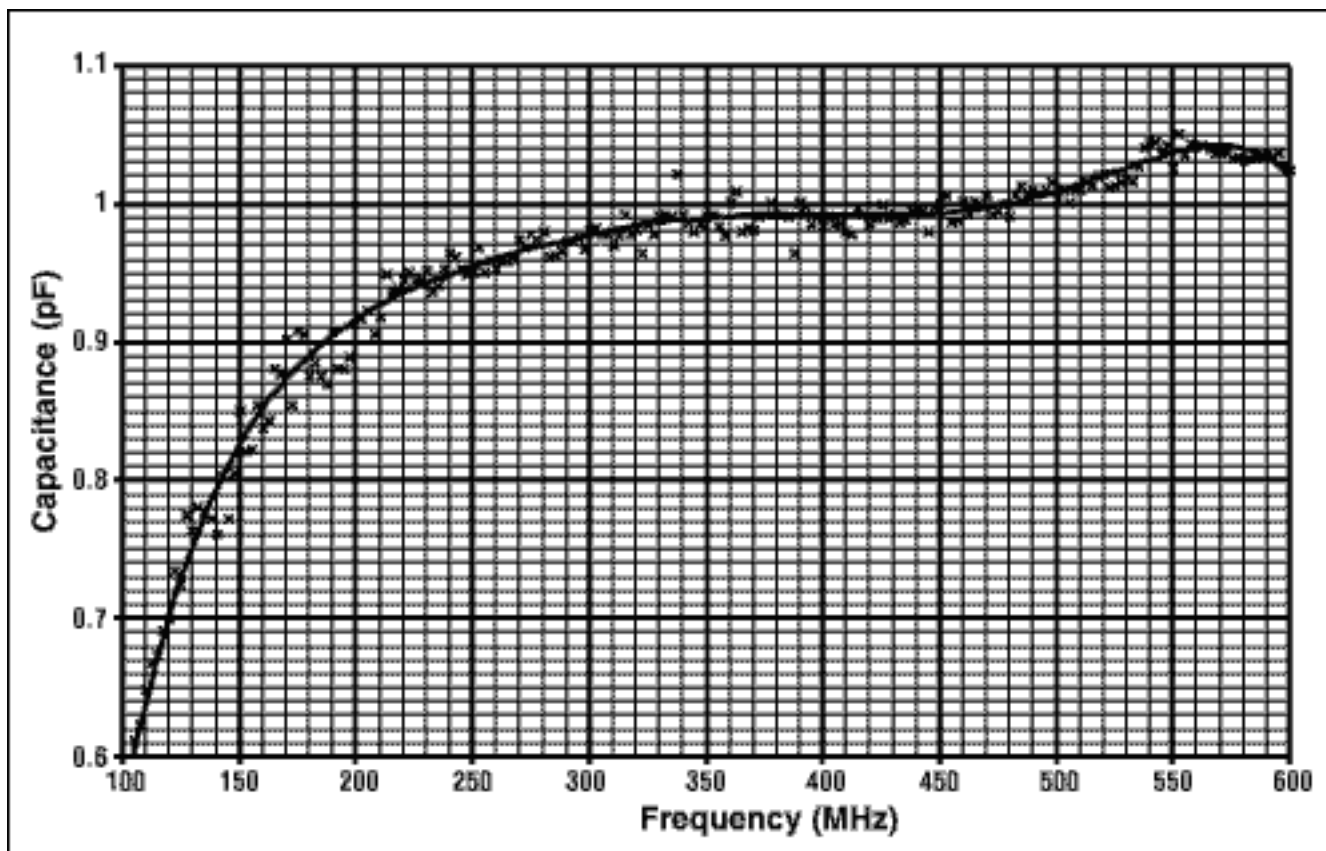

Figure 12. C_{int} vs. frequency for the MAX2310 low-band tank (sixth-order polynomial curve fit).

References

1. Chris O'Connor, Develop Trimless Voltage-Controlled Oscillators, Microwaves and RF, July 1999.
2. Wes Hayward, Radio Frequency Design, Chapter 7.
3. Krauss, Bostian, Raab, Solid State Radio Engineering, Chapters 2, 3, 5.
4. Alpha Industries Application Note AN1004.
5. Coilcraft, RF Inductors Catalog, March 1998, p.131.
6. Maxim, MAX2310/MAX2312/MAX2314/MAX2316 Data Sheet, Rev 0.
7. Maxim, MAX2310/MAX2314 Evaluation Kit Data Sheet, Rev 0.
8. Maxim, MAX2312/MAX2316 Evaluation Kit Data Sheet, Rev 0.

Application Note 530: <http://www.maxim-ic.com/an530>

More Information

For technical questions and support: <http://www.maxim-ic.com/support>

For samples: <http://www.maxim-ic.com/samples>

Other questions and comments: <http://www.maxim-ic.com/contact>

Related Parts

MAX2306: [QuickView](#) -- [Full \(PDF\) Data Sheet](#) -- [Free Samples](#)

MAX2308: [QuickView](#) -- [Full \(PDF\) Data Sheet](#) -- [Free Samples](#)

MAX2309: [QuickView](#) -- [Full \(PDF\) Data Sheet](#) -- [Free Samples](#)

MAX2310: [QuickView](#) -- [Full \(PDF\) Data Sheet](#)

MAX2312: [QuickView](#) -- [Full \(PDF\) Data Sheet](#)

MAX2314: [QuickView](#) -- [Full \(PDF\) Data Sheet](#)

MAX2316: [QuickView](#) -- [Full \(PDF\) Data Sheet](#)

AN530, AN 530, APP530, Appnote530, Appnote 530

Copyright © by Maxim Integrated Products

Additional legal notices: <http://www.maxim-ic.com/legal>