

Keywords: proximity, als, optical, infrared, sensors, tablets, laptops, notebooks, human presence detection, LED

Jul 25, 2011

APPLICATION NOTE 5087

Reach Farther with Your Proximity Sensor

By: Ilya Veygman, Strategic Applications Engineer

Abstract: This article discusses several ways to increase the current that the MAX44000 proximity sensor can drive through an infrared LED. These methods range from very simple to fairly complex, and allow the user to detect objects much farther from the proximity sensor.

Background

The MAX44000 provides a compact and effective infrared proximity sensing solution by integrating powerful functionality into a tiny, 2mm x 2mm x 0.6mm package. The sensor works by pulsing an infrared emitter diode and observing the magnitude of the reflected signal. The larger this signal's magnitude, the closer the target is to the sensor.

In the typical configuration (Figure 1), with no glass in front of the sensor, the device has an effective range of approximately 13cm for an 18% gray card. One of the limiting factors in this situation is the amount of power that the chip can put through the emitter. This reduces the range that the sensor can see and prevents certain features, such as (human) presence detection, from being implemented. Fortunately, there is an easy way to increase the performance of your MAX44000.

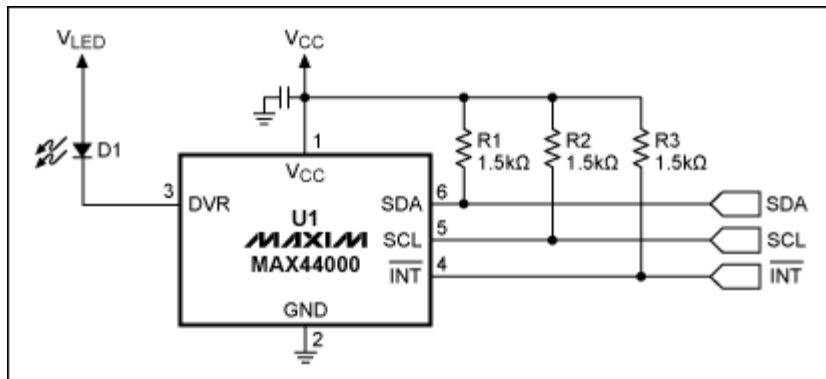

Figure 1. Standard configuration for the MAX44000.

Increasing Power Output

The simplest way of increasing the power output of the emitter is by driving the LED through a FET or another type of transistor. Figure 2 shows how this is done. In this simple example, the MAX44000's DRV pin turns a pMOSFET on and off, driving current through the emitter. The value of the current is set by R5.

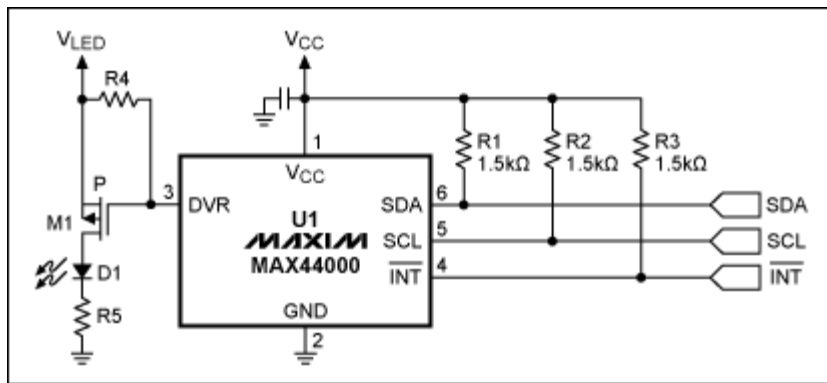

Figure 2. The simplest way to increase LED current.

You can further improve this circuit by more precisely setting the desired current through the emitter, as shown in Figure 3. In this case, a simple op-amp current source sets the current through the LED. A voltage is applied to the positive input of the op amp in the diagram, which is then translated into a current. (In this case, the sense resistor R5 is shown to be 1Ω, so 1V results in 1A.) This voltage can either come from a fixed source, such as a voltage reference, or from a digital-to-analog converter (DAC).

However, the infrared emitter must be pulsed to work best with the MAX44000, so one other stage is added. Here, an analog switch is what feeds the set voltage to the op-amp current driver. The normally closed input is tied to ground, while the normally open input is tied to the desired voltage. By tying a pullup resistor to the control pin, it is possible to switch the analog switch from the NC input to the NO input.

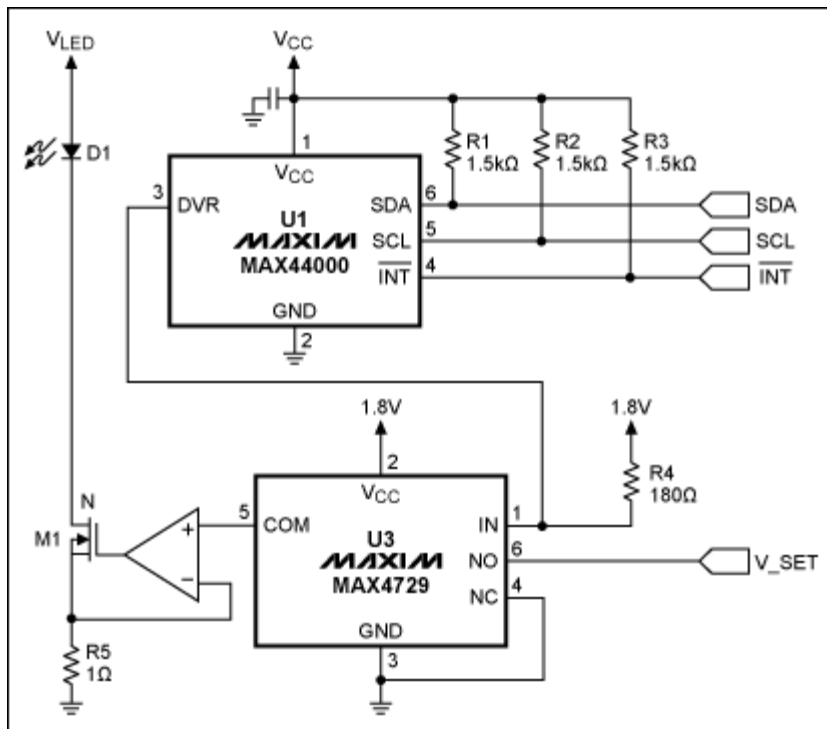

Figure 3. Increased LED power with a current-regulating circuit.

This method is only one way to increase the output power of the emitter, and other similar Maxim parts can be used. Other methods include using the pullup on DRV to send a voltage signal to a controller, which then switches the DAC's output between 0V and the voltage corresponding to the desired current.

The result of increasing the power of the emitter is clear: more current being pumped through the LED means the potential for a longer detection range. An illustration of the increased range is shown in Figure 4, as obtained using the circuit shown in Figure 2. At 30cm (or approximately 1 foot), 400mA and below yields ~10 counts of signal: not much above the noise floor. Increasing the current to 750mA gets us a signal of 32 counts at this distance without requiring lenses or other optical focusing apparatuses.

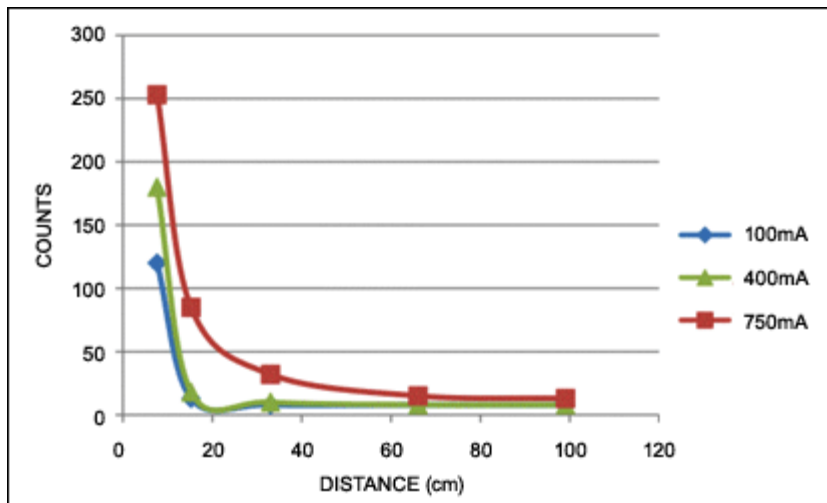

Figure 4. Increased current results in a longer detection range.

Related Parts

- [MAX44000](#) Integrated Ambient Light and Proximity Sensor
- [MAX4729](#) Low-Voltage 3.5Ω, SPDT, CMOS Analog Switches -- [Free Samples](#)

Automatic Updates

Would you like to be automatically notified when new application notes are published in your areas of interest? [Sign up for EE-Mail™](#).

More Information

- For Technical Support: <http://www.maxim-ic.com/support>
- For Samples: <http://www.maxim-ic.com/samples>
- Other Questions and Comments: <http://www.maxim-ic.com/contact>

Application Note 5087: <http://www.maxim-ic.com/an5087>
 AN5087, AN 5087, APP5087, Appnote5087, Appnote 5087
 Copyright © by Maxim Integrated Products
 Additional Legal Notices: <http://www.maxim-ic.com/legal>