

APPLICATION NOTE 500

5-Comparator IC Provides 3V-to-5V Regulator and μ P Reset

Abstract: Using a multi-comparator circuit, a simple boost converter can be constructed to provide a higher output voltage as well as a reset circuit. This application shows how a 3V supply can produce an additional 5V output as well as a power-on-reset (POR) circuit. The application uses the voltage detector to produce an oscillator circuit that controls the external boost circuit and provide a regulated 5V output.

Three-volt systems are becoming common, but they often include at least a few 5V components. A single five-comparator IC can produce the required 5V (from 3V) while generating power-on reset signals for the system microprocessor as well (**Figure 1**).

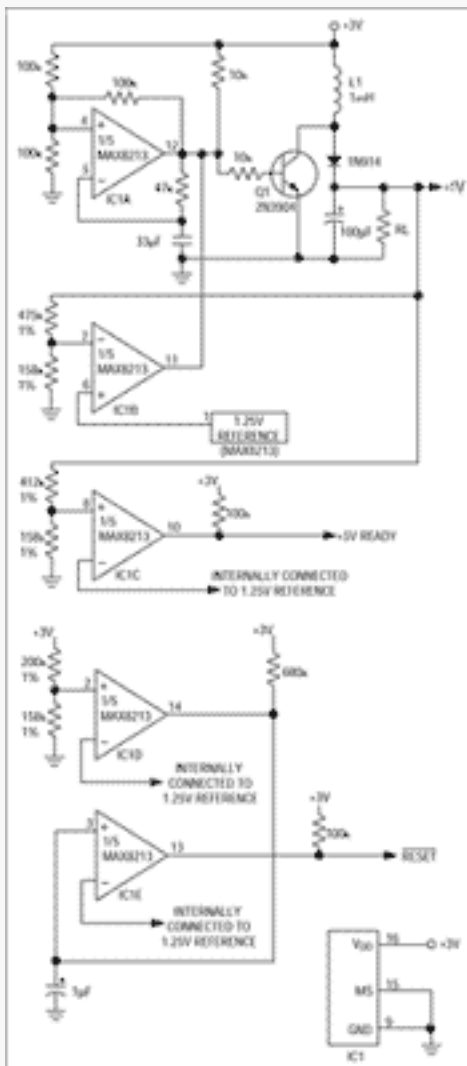

[More detailed image](#) (PDF, 480kB)

Figure 1. This IC and related components boost the 3V supply to 5V, issue "5V ready" signals, and issue μ P-reset signals.

Comparator IC1A is configured as an oscillator whose square-wave output (with approximate 60% duty cycle)

drives the base of Q1. Q1 drives a conventional dc-dc converter consisting of inductor L1, catch diode D2, and C2. When V_{OUT} exceeds 5V, comparator IC1B pulls the oscillator signal low (IC1's open-drain outputs may be tied together without harm). The net effect is regulation at 5V.

IC1's minimum operating voltage is 2.7V, and when the circuit is operated at that voltage it can supply 2.8mA at 5V with 60% efficiency. L1 is an inexpensive 1mH inductor with a series resistance of about 25 Ω . For higher current and better efficiency, you must lower this resistance by providing a more expensive inductor. Output ripple, which is almost entirely due to the hysteresis built into comparator IC1B, is about 50mV.

Comparator IC1C provides an active-high "5V ready" signal when the boost regulator's output reaches 4.5V—the level at which most 5V logic is operable.

Comparators IC1D and IC1E provide a reset for the microprocessor when the 3V supply is too low (below 2.83V). Active-low RESET goes low when the supply voltage falls below this threshold, and remains low for 200ms after it rises above the threshold. For the positive-going supply voltage, hysteresis raises the threshold to approximately 2.87V. The 200ms interval assures time for a full reset of the microprocessor after power is restored, and it allows time for recharging any capacitors associated with the circuit.

A related application for the five comparators of IC1 is to translate the logic signals generated by 3V devices to the levels appropriate for 5V devices.

Related Parts

MAX8213: [QuickView](#) -- [Full \(PDF\) Data Sheet](#) -- [Free Samples](#)

Automatic Updates

Would you like to be automatically notified when new application notes are published in your areas of interest? [Sign up for EE-Mail™](#).

Application note 500: www.maxim-ic.com/an500

More Information

For technical support: www.maxim-ic.com/support

For samples: www.maxim-ic.com/samples

Other questions and comments: www.maxim-ic.com/contact

AN500, AN 500, APP500, Appnote500, Appnote 500

Copyright © by Maxim Integrated Products

Additional legal notices: www.maxim-ic.com/legal