



APPLICATION NOTE 486

MAX2388 at 190MHz IF for WCDMA

Abstract: Bench measurement data is provided for the MAX2387 WCDMA low-noise amplifier (LNA) and mixer for a 2140MHz RF and 190MHz IF. The IF output has been re-matched for 190MHz, and the new bill of materials is provided.

Additional Information

- [Wireless Product Line Page](#)
- [Quick View Data Sheet for the MAX2387/MAX2388/MAX2389](#)
- [Applications Technical Support](#)

Introduction to the MAX238X

The MAX2387, MAX2388, and MAX2389 are members of a family of receive front-end devices designed for WCDMA application. They integrate a low-noise amplifier (LNA) and a high-linearity downconvert mixer in an ultra-small package. The MAX2387 and MAX2388 include a local oscillator (LO) input buffer, whereas the MAX2389 eliminates the LO buffer to provide lower current consumption.

All devices feature a high-gain and low-gain mode of operation, with a 32dB gain step for the MAX2387 and an 18dB gain step for the MAX2388/MAX2389. The ICs also include a shutdown mode for powering-down the IC.

The mixer's 3rd-order nonlinearity performance can be adjusted using an external bias resistor through the BIAS_SET pin to obtain balance between desired linearity and acceptable current consumption. For the MAX2387 and MAX2388, mixer performance is optimized for a -10dBm typical drive at the LO input buffer port. The MAX2389's mixer performance is optimized for a -4dBm typical drive at the LO input port. The LO port for all versions is configurable for either single-ended or differential operation.

Measured Performance

Most of the measurement data shown below were taken on the MAX2388 with 190MHz intermediate frequency (IF) at $V_{CC} = 2.8V$. The MAX2387 and MAX2389 were verified to have similar performance.

Test Conditions:

1. $V_{CC} = 2.8V$
2. RF input power = -30dBm
3. RF frequency = 2140MHz; LO frequency = 2330MHz
4. Two-tone spacing = 1MHz
5. LO power = -10dBm (-4dBm for MAX2389)

Table 1. LNA Measurements

Parameter	High Gain	Low Gain	Units	Comments
Gain	14.6	-2.8 (-17 MAX2387)	dB	LNA input loss = 0.2dB and LNA output loss = 0.2dB have been de-embedded from the measurements.
NF	1.8	7.0	dB	LNA input loss = 0.2dB has been de-embedded from the measurement.
IIP3	3.5	1.0	dBm	Measured with RF = -20dBm at low-gain mode
S11	-10.5	-12.9	dB	$10 \cdot \log_{10}(S_{11})$
S22	-13.5	-16.5	dB	$10 \cdot \log_{10}(S_{22})$
S12	-25.4	-12.1	dB	$10 \cdot \log_{10}(S_{12})$
Icc	9.9	6.8	mA	

Table 2. Mixer Measurements

Parameter	High Gain	Low Gain	Units	Comments
Gain	10.5	9.5	dB	Mixer input loss = 0.2 and IF balun insertion loss = 1.0dB have been de-embedded.
NF	6.8	6.2	dB	Mixer input loss = 0.2dB has been de-embedded from the measurement.
IIP3	10.0	1.8	dBm	
IIP2	17.0	16.8	dBm	With single-ended LO drive
IIP2	31.2	30.5	dBm	With differential LO drive
LO Leakage at IF Port	-25.5	-25.5	dBm	LO = -10 dBm @2330MHz MAX2387/88
LO Leakage at RF Port	-45	-45	dBm	LO = -10 dBm @2330MHz MAX2387/88

Table 3. S-Parameters of the LNA at High-Gain Mode

Frequency	S11		S21		S12		S22	
(GHz)	Mag(dB)	Phase(Deg)	Mag(dB)	Phase(Deg)	Mag(dB)	Phase(Deg)	Mag(dB)	Phase(Deg)
1.0	-2.1286	-58.278	12.847	133.75	-32.155	74.423	-0.945	-23.033
1.1	-2.3856	-62.382	12.331	131.49	-32.022	80.579	-0.964	-25.008
1.2	-2.6618	-65.862	12.154	128	-31.585	73.547	-1.089	-24.881
1.3	-2.855	69.138	11.703	126.22	-30.677	77.068	-1.285	-25.903
1.4	-3.1572	-72.628	11.296	123.77	-31.095	76.873	-1.325	-26.516
1.5	-3.4104	-75.839	11.253	120.6	-30.572	75.955	-1.467	-26.709
1.6	-3.7441	-78.872	11.206	121.03	-30.134	77.315	-1.625	-27.577
1.7	-4.1285	-82.259	10.622	117.69	-30.08	80.001	-1.798	-28.049
1.8	-4.3986	-85.465	10.986	116.13	-29.453	82.934	-1.925	-29.221
1.9	-4.7755	-89.3	10.436	115.06	-29.922	83.366	-2.098	-29.713
2.0	-5.2184	-92.921	10.444	110.19	-29.151	84.624	-2.267	-30.994
2.1	-5.6356	-96.942	10.353	108.99	-28.898	86.776	-2.345	-32.867
2.2	-6.0176	-101	10.29	105.5	-28.514	87.56	-2.451	-35.262
2.3	-6.4621	-106.27	10.58	104.32	-27.631	89.437	-2.685	-38.079
2.4	-6.9126	-111.35	9.8114	100.88	-27.764	88.93	-2.835	-42.528
2.5	-7.2807	-117.04	10.106	95.216	-27.384	88.897	-3.018	-46.811
2.6	-7.7233	-122.7	9.7148	95.186	-26.945	88.47	-3.077	-51.827
2.7	-7.9908	-130.37	9.0991	88.322	-26.888	93.211	-3.077	-57.443
2.8	-8.2315	-137.57	9.6216	84.239	-26.285	89.688	-3.257	-63.369
2.9	-8.2342	-144.27	9.0162	85.306	-26.094	95.284	-3.305	-69.697
3.0	-8.3826	-151.69	8.5833	77.645	-26.065	91.953	-3.198	-75.708

Mixer OIM3 versus RF Input Power

Test conditions are the same for the gain, IIP3, and NF measurements stated previously.

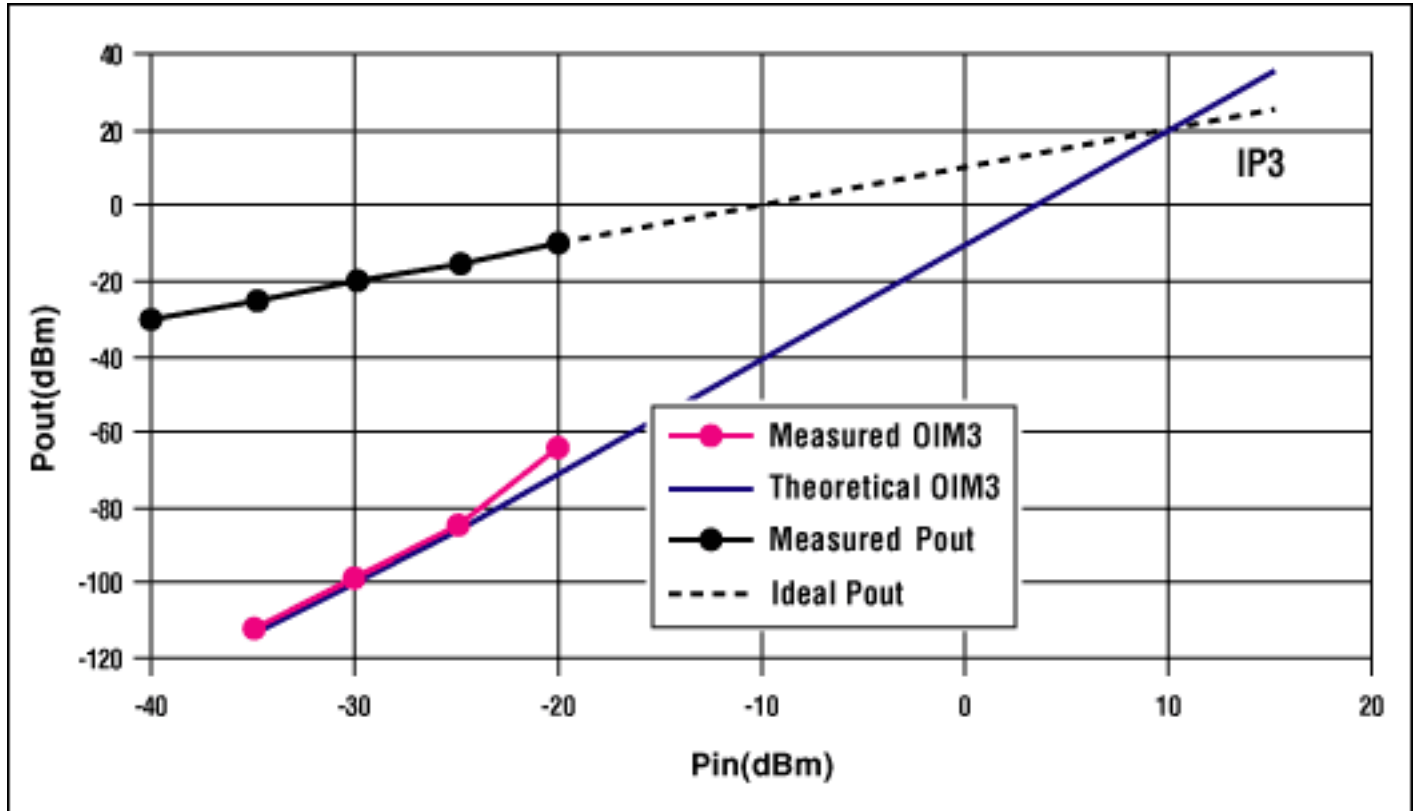

Figure 1. MAX2388 mixer IIM3 versus pin.

Mixer IIP3 versus V_{CC}

The mixer features very high linearity with low current consumption. Feedback is the novel technique used to improve IIP3 with low current consumption. However, the feedback is optimized at $V_{CC} = 2.7V$. If V_{CC} deviates from 2.7V, IIP3 does not obtain the optimum value of approximately +12dBm. The following figure shows the IIP3 change versus V_{CC} .

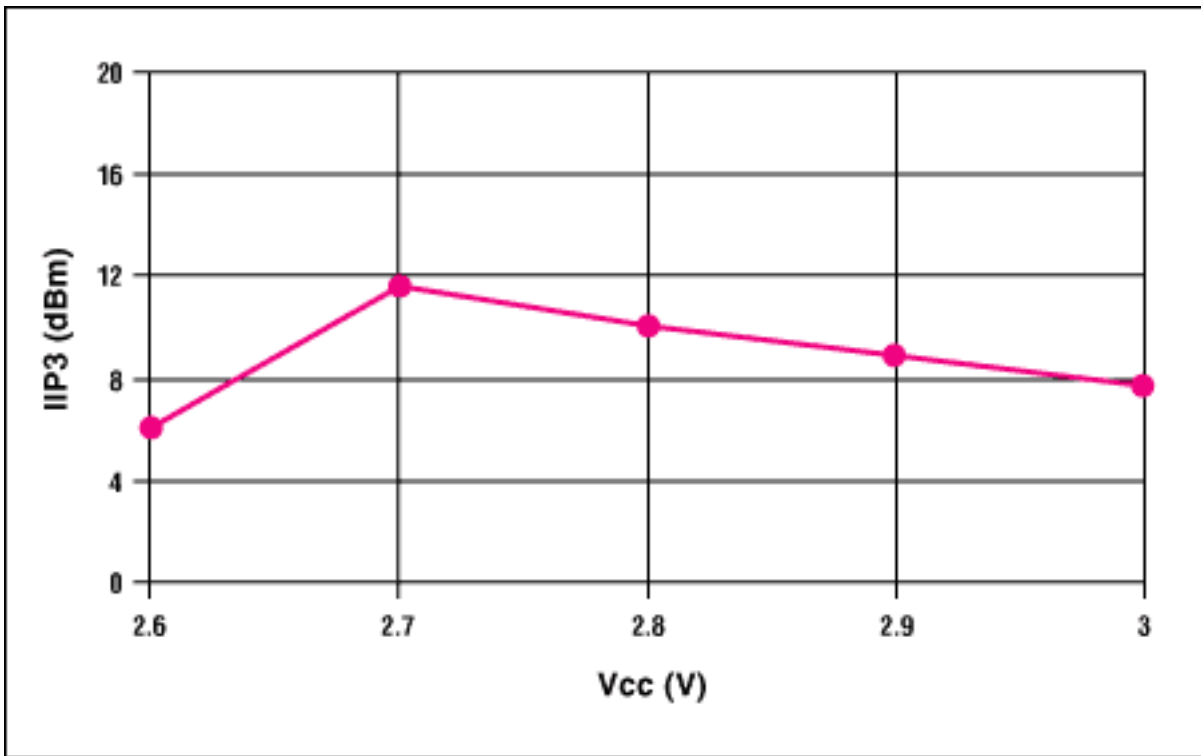

Figure 2. Mixer IIP3 versus V_{CC} .

Test Setup

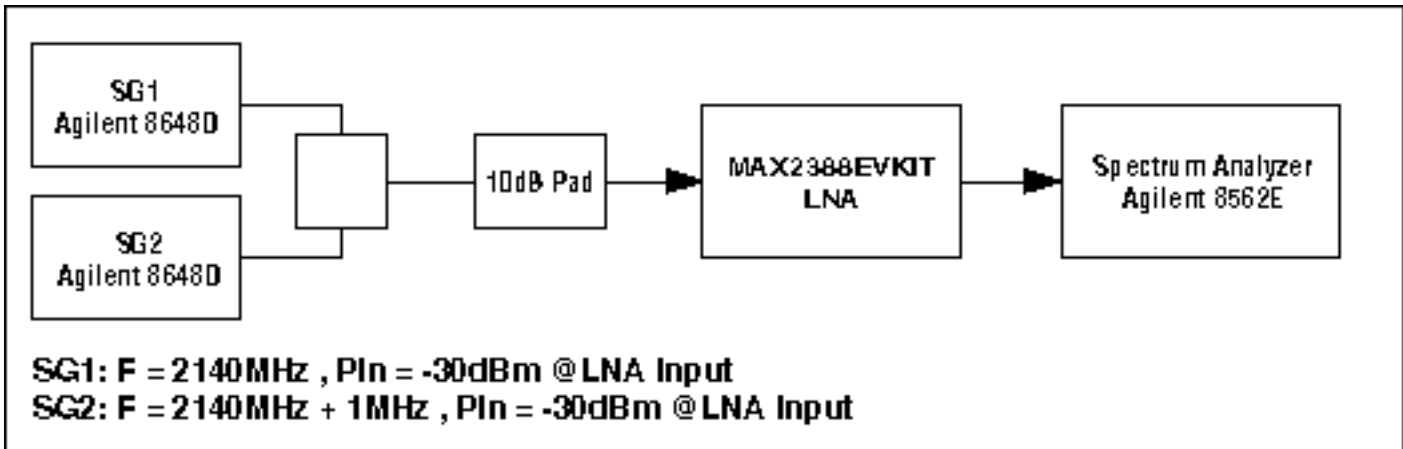

Figure 3. MAX2388 LNA IIP3 measurement.

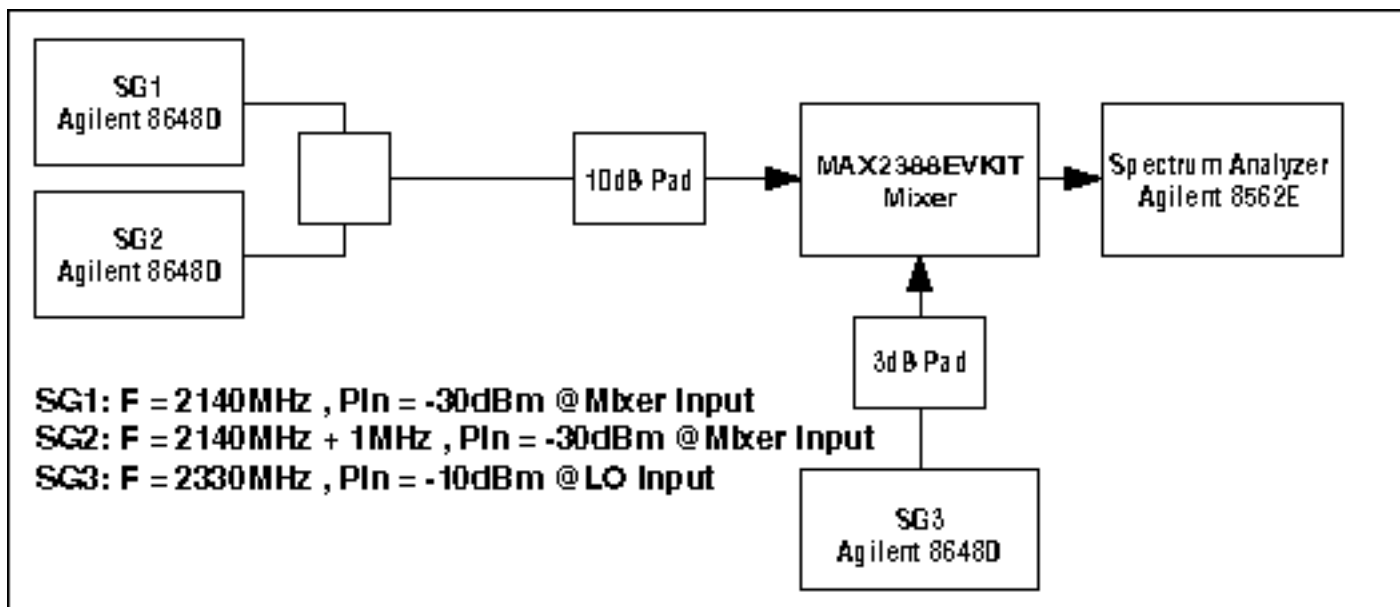

Figure 4. MAX2388 mixer IIP3 measurement.

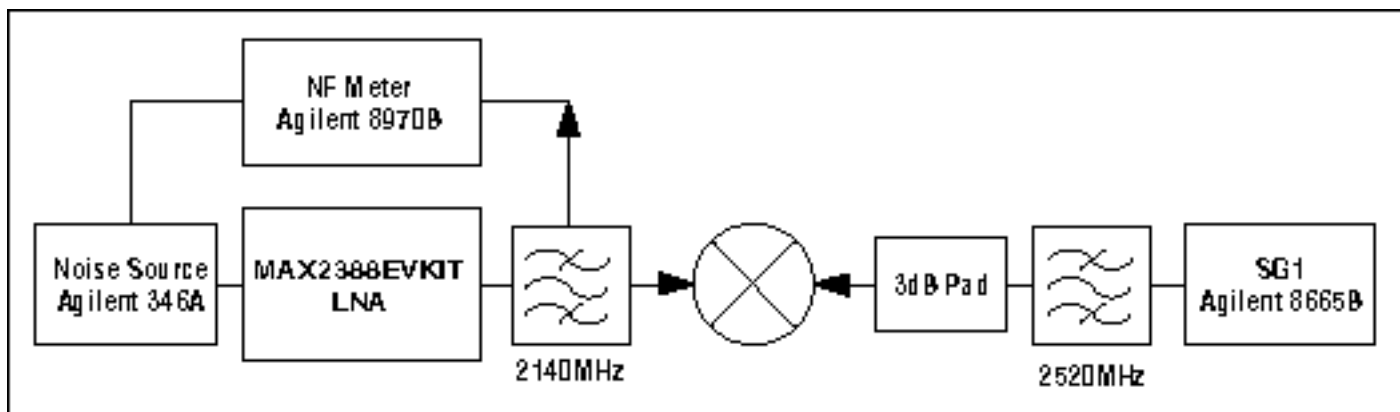

Figure 5. MAX2388 LNA NF measurement.

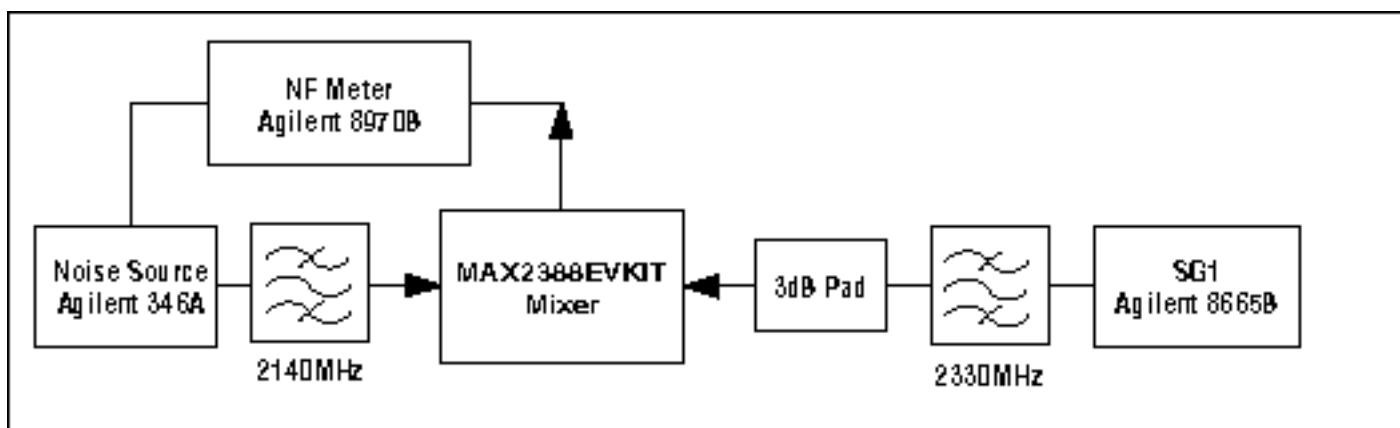

Figure 6. MAX2388 mixer NF measurement.

[Bill of Materials for 190MHz IF Match of the Mixer](#) (PDF, 11K)

[MAX2387 Evaluation Kit](#) (PDF, 45K)

Application Note 486: <http://www.maxim-ic.com/an486>

More Information

For technical questions and support: <http://www.maxim-ic.com/support>

For samples: <http://www.maxim-ic.com/samples>

Other questions and comments: <http://www.maxim-ic.com/contact>

Related Parts

MAX2387: [QuickView](#) -- [Full \(PDF\) Data Sheet](#)

MAX2388: [QuickView](#) -- [Full \(PDF\) Data Sheet](#)

MAX2389: [QuickView](#) -- [Full \(PDF\) Data Sheet](#)

AN486, AN 486, APP486, Appnote486, Appnote 486

Copyright © by Maxim Integrated Products

Additional legal notices: <http://www.maxim-ic.com/legal>