

APPLICATION NOTE 480

# Circuit Provides Reverse-Battery Protection

Additional Information:

- [Quick View Data Sheet for the MAX4636](#)
- [Samples and Literature Order Form](#)
- [Technical Support: Power](#)

A universal problem in battery-operated devices is the threat of damage when an end user (never an engineer) inserts the battery backward. You can avoid damage by inserting a single diode or by using a diode-bridge configuration, but those fixes waste power and reduce the supply voltage by adding one or two diode drops between the battery and the supply rail. An alternative solution not only protects against battery-reversal damage but also automatically corrects the reversal (see the figure below). To eliminate the voltage drops associated with discrete diodes, a low-on-resistance, DPDT (double-pole/double-throw) switch serves as a full-wave rectifier. When you insert the battery with the correct polarity as shown, the upper switch,  $S_1$ , is in its normally closed state, because its control pin is in its low state. The resulting connection from pin 2 to pin 10 provides a low-impedance path from the battery to the  $V_{CC}$  terminal. Conversely, the lower switch,  $S_2$ , closes its normally open terminal (not as shown), because its control pin is in its high state. The resulting path from pin 7 to pin 6 connects the battery's negative terminal to ground.

The ESD-protection diodes in  $IC_1$  guarantee startup and act as a full-wave rectifier. MOSFETs internal to the analog switch turn on when the battery voltage exceeds 1V. Their less-than-20-nsec turn-on time enables the circuit to maintain normal operation by quickly swapping the leads of a reversed-polarity battery connection. The circuit resistance depends on the battery voltage. When the circuit operates from four NiCd, NiMH, or alkaline cells, the resistance in each leg of the rectifier is  $2.5\Omega$  ( $5\Omega$  total). Operation with a two-cell battery (2.4V to 3V) yields a total resistance of  $10\Omega$ .  $IC_1$  is rated for operation to 5.5V with 30-mA continuous current, making the circuit useful for cordless phones, portable audio equipment, hand-held electronics, and other light- to medium-current applications.  $IC_1$ 's miniature 10-pin  $\mu$ MAX package takes less space than four through-hole signal diodes and is almost as small as two SOT-23 dual signal diodes.

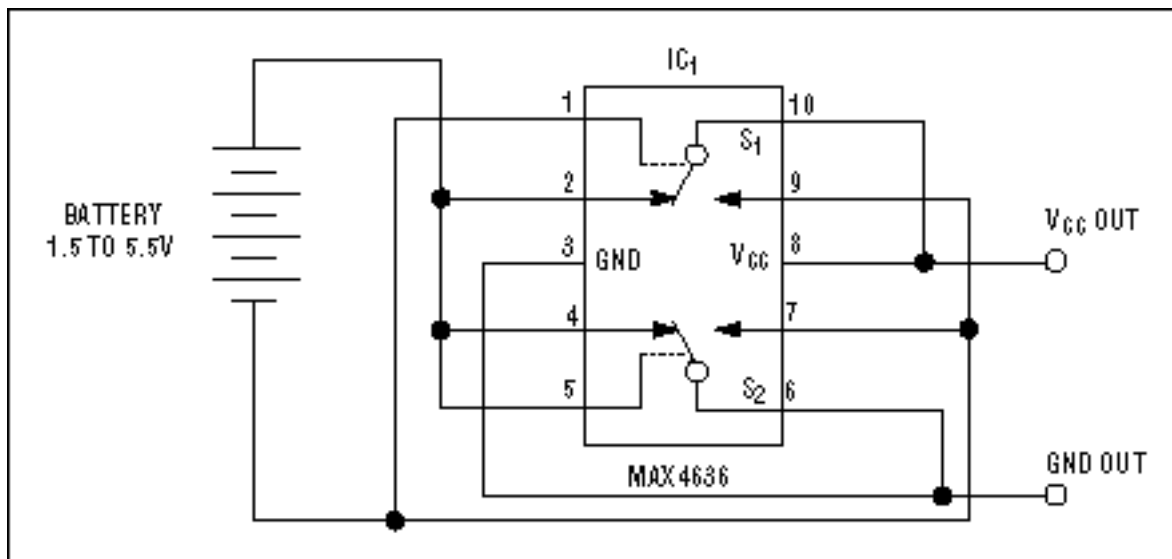

Figure 1. This circuit senses battery polarity and then quickly connects the load or swaps the battery leads.

A similar version of this article appeared in the December 21, 2000 issue of *EDN*.

---

Application Note 480: [www.maxim-ic.com/an480](http://www.maxim-ic.com/an480)

### **More Information**

For technical support: [www.maxim-ic.com/support](http://www.maxim-ic.com/support)

For samples: [www.maxim-ic.com/samples](http://www.maxim-ic.com/samples)

Other questions and comments: [www.maxim-ic.com/contact](http://www.maxim-ic.com/contact)

---

### **Automatic Updates**

Would you like to be automatically notified when new application notes are published in your areas of interest?

[Sign up for EE-Mail™.](#)

---

### **Related Parts**

MAX4636: [QuickView](#) -- [Full \(PDF\) Data Sheet](#) -- [Free Samples](#)

AN480, AN 480, APP480, Appnote480, Appnote 480

Copyright © by Maxim Integrated Products

Additional legal notices: [www.maxim-ic.com/legal](http://www.maxim-ic.com/legal)