

Design Note:
HFDN-4.0
Rev.2; 04/08

***Simulating Direct Laser Modulation
with the MAX3930***



Maxim Integrated Products



Simulating Direct Laser Modulation with the MAX3930

1. Introduction

The MAX3930 is designed for direct modulation of laser diodes at data rates up to 10.7Gbps. Operating from a single +5.0V or -5.2V power supply, the driver output can be DC-coupled to a common-anode laser diode, delivering a modulation current of 20mA to 100mA with an edge speed of 25ps. Proper design of the interfacing circuit between the laser and the driver is critical to control optical transmitter output performance at 10.7Gbps. The purpose of this article is to establish a simulation model for transient analysis and to address driver-to-laser interfacing.

2. Modeling the MAX3930 Modulation Output Stage

The MAX3930 modulation output is optimized for driving a 20Ω load. The minimum voltage required at MOD1 and MOD2 is 1.55V. To interface with a laser diode (Figure 1), a series damping resistor of 15Ω is necessary to achieve the required load condition, assuming a laser-diode resistance of 5Ω. Figure 2 shows a simplified schematic for the driver modulation output stage, including the load and voltage sources for the modulation current setting (V_M) and transient analysis (V_S).

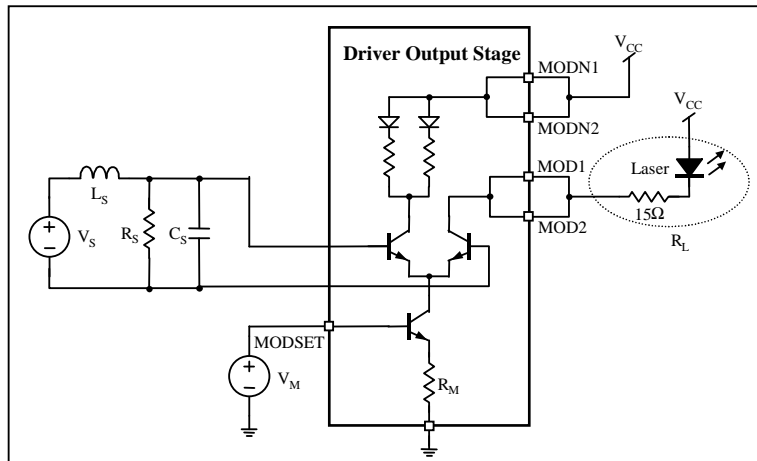

Figure 1. Driver modulation output stage and peripheral circuits for simulation

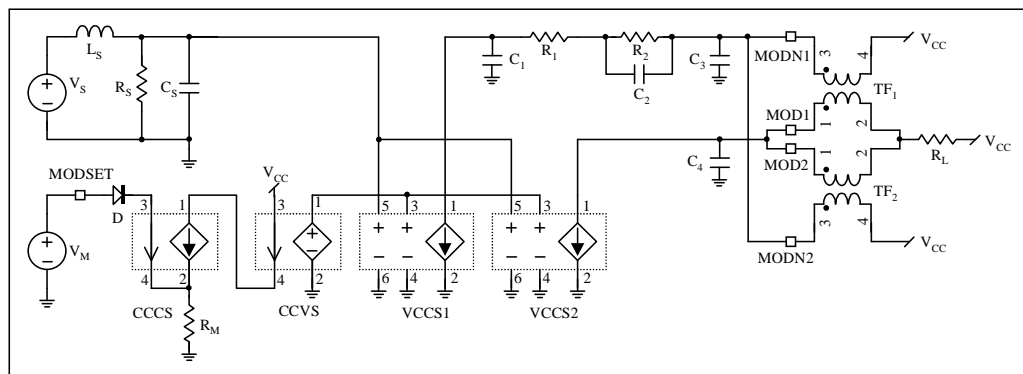

Figure 2. Simplified model for the driver modulation output stage and simulation circuit

The laser modulation current swing is set by a voltage of V_M at the MODSET pin. The voltage source V_S and the network composing of L_S , R_S , and C_S are to imitate the signal that drives the output stage. Both pads of the modulation outputs (MOD1 and MOD2) and the complementary modulation outputs (MODN1

and MODN2) are wire-bonded out, assuming a 1mm wire length. Transformers TF1 and TF2 present the self-inductance of each bond wire and the coupling between two complementary outputs. The load impedance R_L can be replaced with a corresponding model to simulate a laser-diode assembly.

3. Parameters

The following table summarizes the parameters of all the components.

Symbol	Component Type	Parameters and Description
C_1	Linear Capacitor	1.0pF
C_2	Linear Capacitor	0.7pF
C_3	Linear Capacitor	0.4pF
C_4	Linear Capacitor	1.1pF
C_S	Linear Capacitor	4.3pF
D	Diode	Saturation Current: $I_s = 2.3 \times 10^{-18}$ Emission Coefficient: $n = 1$ Junction Built-in Voltage: $PB = 930\text{mV}$
L_S	Linear Inductor	12.8pH
R_1	Resistor	19.0 Ω
R_2	Resistor	1.0 Ω
R_L	Laser Equivalent Resistance	20.0 Ω
R_M	Resistor	3.0 Ω
R_S	Resistor	1 Ω
TF1	Transformer	$L1 = 1.0\text{nH}$, $L2 = 1.0\text{nH}$, $K12 = 0.2$
TF2	Transformer	$L1 = 1.0\text{nH}$, $L2 = 1.0\text{nH}$, $K12 = 0.2$
CCCS	Current-Controlled Current Source	$I_{1,2} = P_0 + P_1 \times I_{3,4}$ $P_0 = 0$, $P_1 = 150$
CCVS	Current-Controlled Voltage Source	$V_{1,2} = P_0 + P_1 \times I_{3,4}$ $P_0 = 0$, $P_1 = 1\Omega$
V_{CC}	Independent Voltage Source	Power-supply voltage, +4.75V to +5.5V.
VCCS1	Voltage-Controlled Current Source	$I_{1,2} = P_0 + P_2 \times V_{5,6} + P_4 \times V_{3,4} \times V_{5,6}$ $P_0 = 0$, $P_2 = 1$, $P_4 = -1$
VCCS2	Voltage-Controlled Current Source	$I_{1,2} = P_0 + P_4 \times V_{3,4} \times V_{5,6}$ $P_0 = 0$, $P_4 = 1$
V_M	Independent Voltage Source	DC voltage to set the laser modulation current.
V_S	Pulsed Independent Source	Initial Value = 0, Pulsed Value = 1V, Delay Time = 0, Rise Time = 12ps, Fall Time = 12ps, Pulse Width = 500ps, Period = 1ns