

APPLICATION NOTE 4709

# MAX9259 GMSL Line Fault Detection

By: Alex Shih  
Rob James

*Abstract: This application note describes an easy way to detect serial-link line faults (e.g., line shorts) in serializer/deserializer (SerDes) applications. The approach described here uses the serializer's built-in monitoring circuit, an external n-channel MOSFET (or analog switch), and a resistor network. The MAX9259 gigabit multimedia serial link (GMSL) is featured.*

The MAX9259 has a built-in line fault monitor circuit to detect serial link failures, such as line shorts to the power supply (or battery in an automobile), shorts to ground, or open lines. Figure 1 shows the original circuit and required external resistors as depicted in the MAX9259 data sheet.

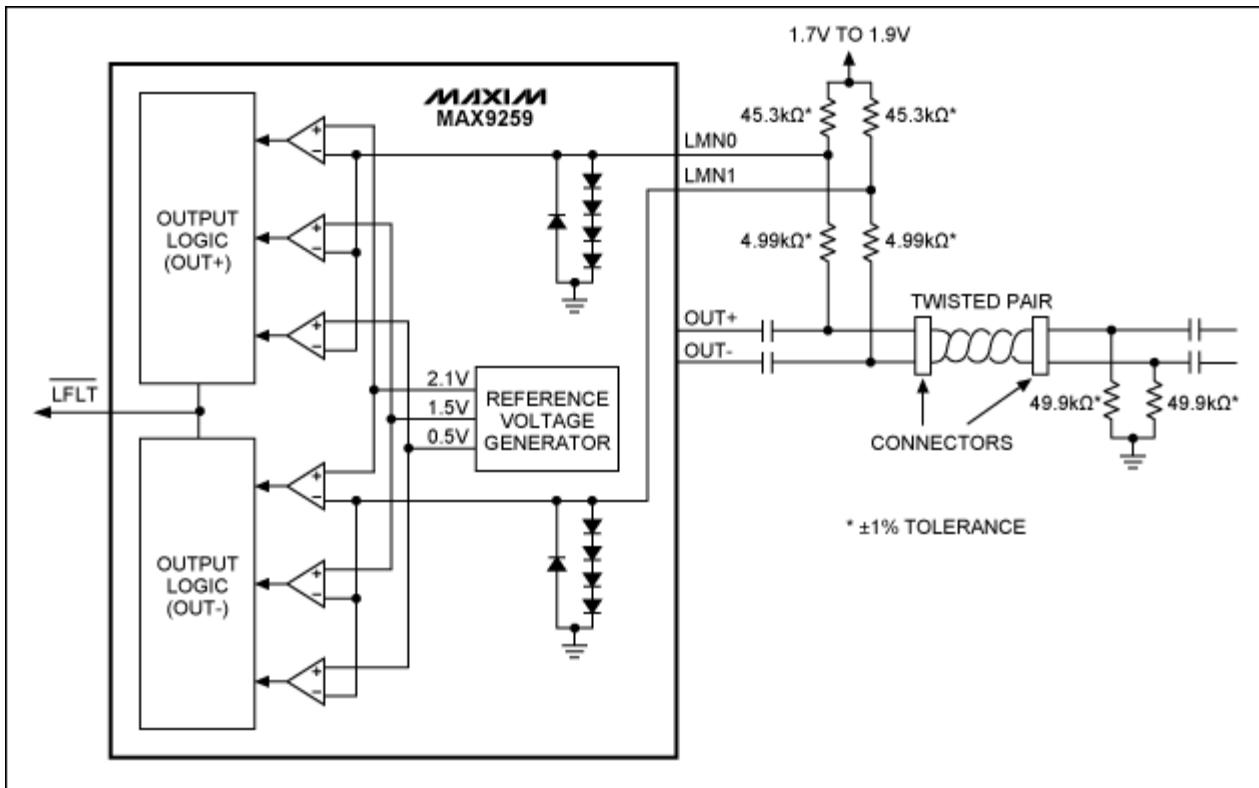

Figure 1. Original line fault detection circuit.

With two extra components, the line fault monitor coverage can be extended to also detect a short circuit of the twisted-pair cable (Figure 2).

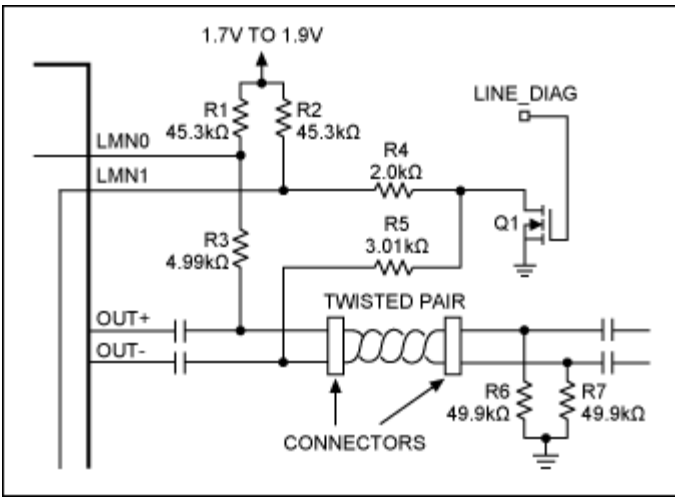

Figure 2. Line fault detection circuit covers short-circuit detection.

The new, enhanced circuit (Figure 2) splits the 4.99kΩ resistor into two; one is 2.0kΩ (R4) and the other is 3.01kΩ (R5). An n-channel MOSFET (Q1) is added as a switch. The drain of Q1 connects to the node between R4 and R5. The source of Q1 is tied to ground.

When the signal LINE\_DIAG (connected to the gate of Q1) transitions low, Q1 is turned off. The new circuit function is exactly the same as the original circuit shown in Figure 1, but adds short-circuit detection of the twisted-pair cable.

When LINE\_DIAG transitions high, Q1 is turned on and connects the node between R4 and R5 to ground.

If there is no short between the two wires of the twisted-pair cable, Q1 connects the node between R4 and R5 to ground. The resulting circuit, Figure 3, is a simplified version of Figure 2.

Under this condition, only the level of LMN1 is affected by Q1. The voltage of LMN0 is still at its normal level. However, with the supply voltage between 1.7V and 1.9V, the voltage of LMN1 now becomes low enough to detect a short-to-ground condition. As a result, the MAX9259 active-low LFLT output transitions low; the register 0x08 bits D[1:0] read as LFPOS = 10 (normal) and bits D[3:2] read as LFNEG = 01 (short-to-ground).

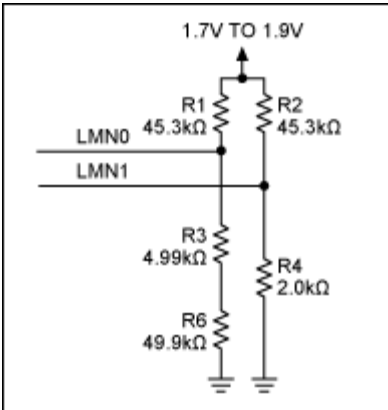

Figure 3. No short circuit.

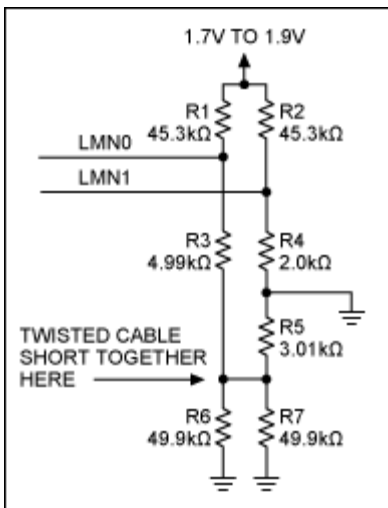

Figure 4. Short circuit detected.

When the two wires in a twisted-pair cable are shorted together, the circuit of Figure 2 becomes equivalent to the one displayed in Figure 4. Q1 connects the same node to ground, but since the twisted-pair cable is shorted, it affects the voltage level of LMN0.

With a supply voltage of 1.7V to 1.9V, the voltage for LMN0 and LMN1 will be below the 0.3V maximum short-to-ground threshold listed in the MAX9259 data sheet. As a result of this, the MAX9259's active-low LFLT output transitions low, register 0x08 bits D[1:0] read as LFPOS = 01 (short-to-ground) and bits D[3:2] read as LFNEG = 01 (short-to-ground).

MOSFET leakage current (Zero Gate Voltage Drain Current  $I_{DSS}$ ) is an important factor for proper operation of the circuit described in this application note. For correct operation this must not exceed  $3\mu\text{A}$  at  $V_{DS} = 1\text{V}$  over the temperature range required by the application. MOSFET on resistance is also important and must not exceed  $20\Omega$  at  $V_{GS} = 1.7\text{V}$ .

Equally important is the matching of the resistor pair. For the circuit displayed in Figure 2, R1 should be equal to R2, R3 should be equal to R4 + R5, and R6 should be equal to R7.

Please refer to the MAX9259 data sheet for detailed information about the internal registers and the line fault threshold values of LMN0 and LMN1.

Finding a MOSFET which is qualified for automotive use (if required) and has sufficiently low leakage can be a challenge, since most devices have leakage specified at conditions that differ from those in the circuits here. MOSFETs such as the BSS138LT1 from ON Semiconductor® and FDG327NZ/FDZ372NZ from Fairchild™ can be considered. The data sheets for these parts specify leakage current only at room temperature, but the manufacturers' test data shows that the leakage current at  $-40^\circ\text{C}$ , room temperature, and at  $+150^\circ\text{C}$  does not exceed  $3\mu\text{A}$ .

An alternative to a MOSFET is an analog switch, as shown in Figure 5. Single gate devices based on the CD4066 are widely available as parts numbered xxx1G66 (such as the NX3L1G66 from NXP®). These devices have leakage current extensively characterized for circuits such as the one shown here over the complete automotive temperature range.

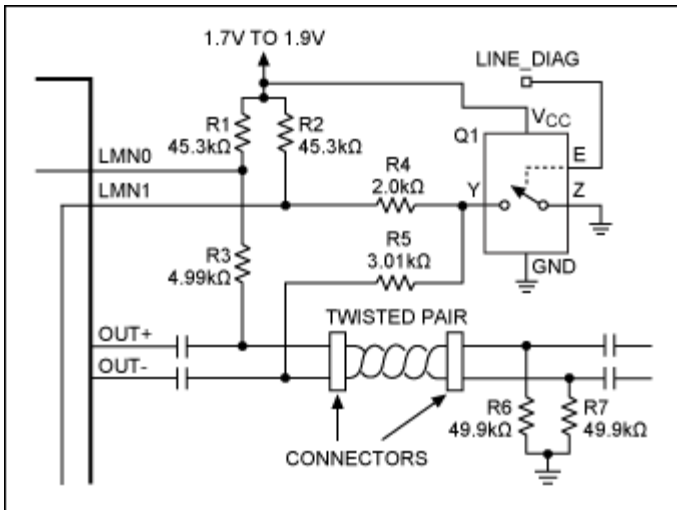

Figure 5. Line fault detection circuit using analog switch.

Fairchild is a trademark of Fairchild Semiconductor Corporation.

NXP is a registered trademark of NXP B.V.

ON Semiconductor is a registered trademark and registered service mark of Semiconductor Components Industries, L.L.C.

#### Related Parts

[MAX9259](#) Gigabit Multimedia Serial Link with Spread Spectrum and Full-Duplex Control Channel

#### Automatic Updates

Would you like to be automatically notified when new application notes are published in your areas of interest? [Sign up for EE-Mail™](#).

Application note 4709: [www.maxim-ic.com/an4709](http://www.maxim-ic.com/an4709)

More information

For technical support: [www.maxim-ic.com/support](http://www.maxim-ic.com/support)

For samples: [www.maxim-ic.com/samples](http://www.maxim-ic.com/samples)

Other questions and comments: [www.maxim-ic.com/contact](http://www.maxim-ic.com/contact)

AN4709, AN 4709, APP4709, Appnote4709, Appnote 4709

Copyright © by Maxim Integrated Products

Additional legal notices: [www.maxim-ic.com/legal](http://www.maxim-ic.com/legal)