

APPLICATION NOTE 4607

# Add a Discrete Jack-Sensing Circuit to the MAX13330/MAX13331 Automotive Headphone Amplifier

By: Jon Wallace

*Abstract: This application note describes how to add a discrete jack-sensing (JACKSENSE) circuit to the MAX13330/MAX13331 DirectDrive® headphone amplifier.*

## Introduction

The [MAX13330/MAX13331](#) automotive headphone amplifier meets the requirements of most automotive applications, but there are instances where other features are needed. Sensing when a headphone is inserted into the audio jack is sometimes an application requirement. This capability can easily be added to any DirectDrive headphone amplifier, as long as there is a microcontroller available to decode the additional signals generated.

## Jack-Sensing Circuit

Adding a discrete jack-sensing circuit to a device typically requires just a few low-cost passive components. The exact values of each component depend on the system requirements, but the basic circuit should remain the same. Typically a four-contact audio jack is used where the extra contact is a normally-closed switch connected to the left or right audio contact. When a plug is inserted the switch opens. The circuit in **Figure 1** shows the basic jack-sensing circuit. **Figure 2** shows a schematic diagram of the MAX13330/MAX13331 with the jack-sensing circuit.

The jack-sensing circuit can be used to automatically enable the MAX13330/MAX13331 when a plug is inserted into the jack. Connect the output of the jack-sensing circuit directly to the active-low SHDN pin to implement this function.

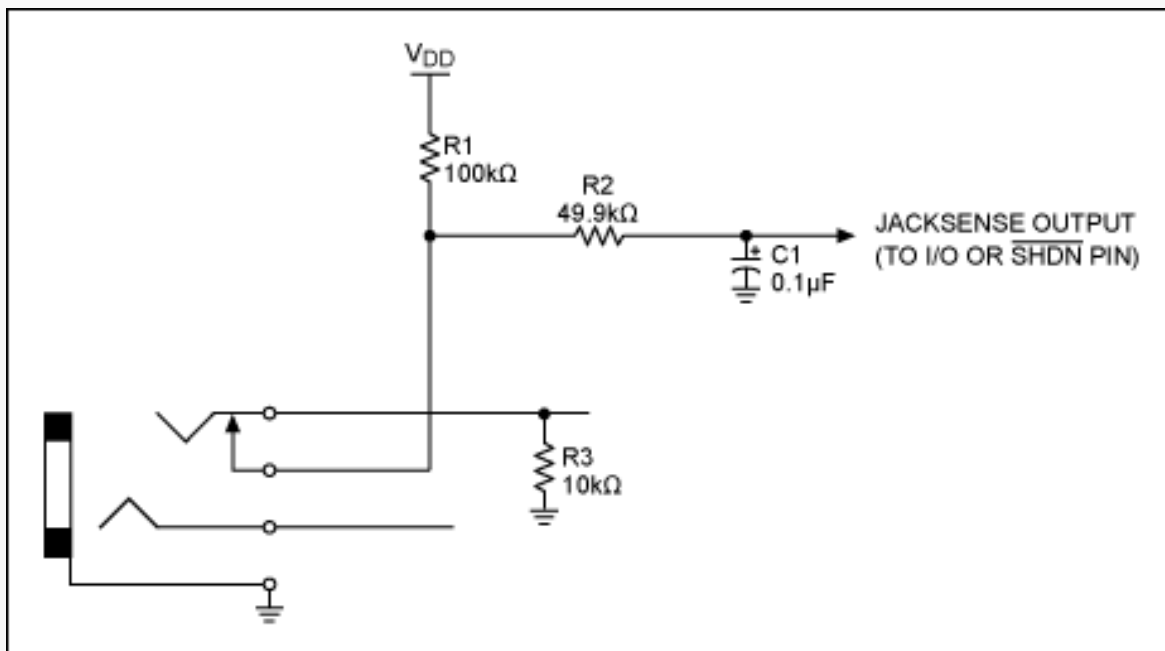

Figure 1. Jack-sensing circuit.

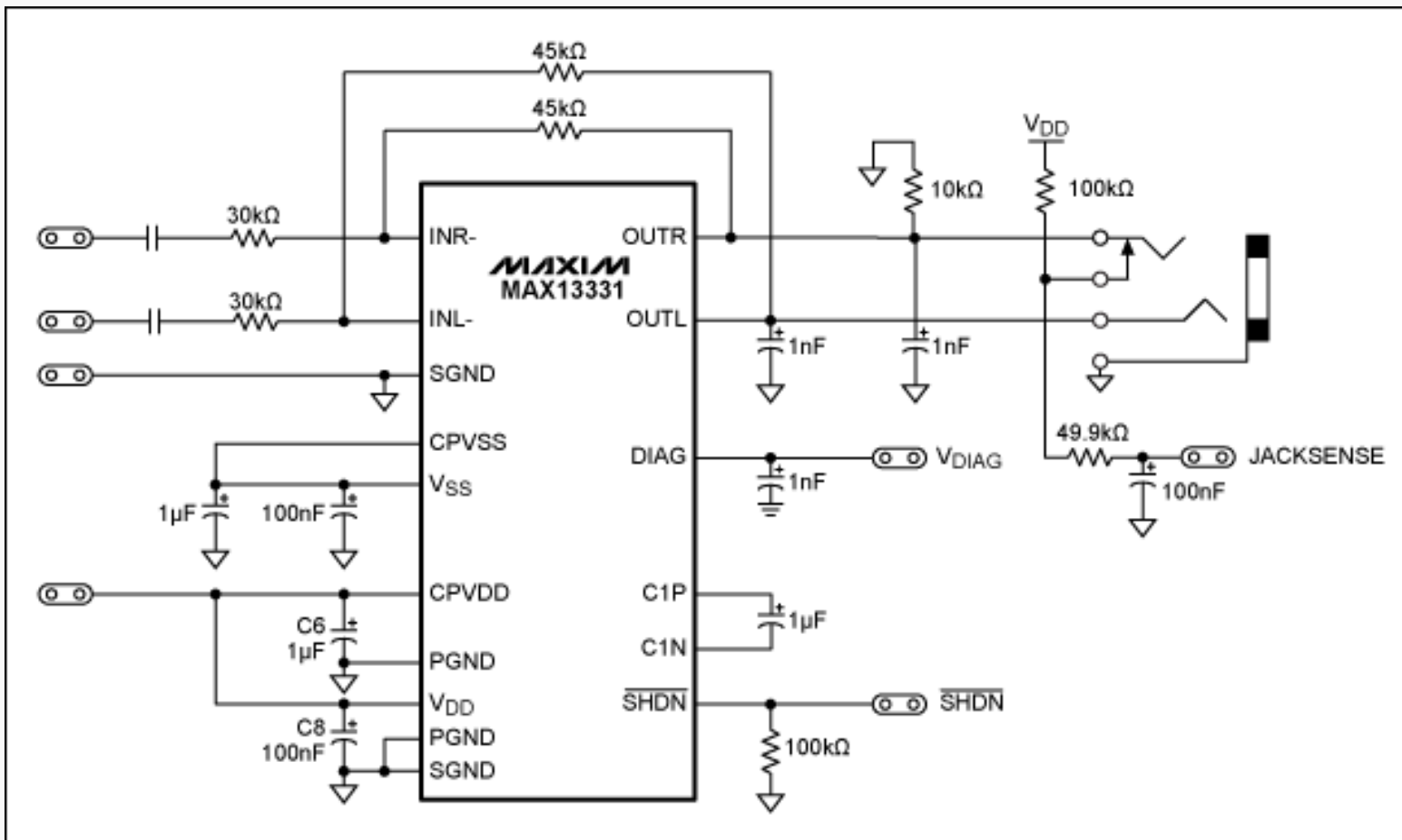

Figure 2. Schematic diagram of MAX13331 with discrete jack-sensing circuit.

## Filter Selection

The RC filter consists of R2 and C1, and allows the jack-sensing detection times to be adjusted and the audio signals to be filtered. R2 and C1 can be selected to meet the requirements of each application. **Table 1** gives a typical range of C1 capacitor values along with associated jack detection times and RC filter parameters.

If audio will be present when no plug is inserted into the jack and if the rising threshold of the digital input is  $< 2.2V$ , then select a capacitor value that will filter out the audio signal. The MAX13330/MAX13331 has a maximum audio signal of  $\sim 2.2V$ . Therefore, a capacitor value of  $0.47\mu F$  is adequate to keep the jack-sensing output below  $0.6V$ , which will be a "0" for most digital inputs. To minimize the jack detection times, adjust the capacitor value based on the specific digital input threshold.

A Schmitt-trigger inverter or buffer can be added to eliminate the need to filter the audio signal, as the rising-edge threshold will be above the maximum audio signal. With the small cost of the inverter/buffer, this modification provides the added flexibility of adjusting the jack detection times.

**Table 1. Typical C1 Filter Values**

C1 ( $\mu F$ )	Jack-Present Detection Time (ms) *	Plug-Removal Detection Time (ms) **	Cutoff Freq. (Hz)	-12dB (Hz)
0.01	1	0.4	320	1234
0.047	5	1.6	68	264
0.1	10	3.5	32	123
0.22	23	8	15	44
0.47	49	16	7	27
1.0	104	35	3	12

\*MAX13330/MAX13331 disabled (EN low)

\*\*MAX13330/MAX13331 enabled (EN high) with no audio present.

## Conclusion

There are varying requirements which impact the design of a jack-sensing circuit. but adding a discrete jack-sensing output to the MAX13330/MAX13331 headphone amplifier typically requires only a few low-cost components. The jack-sensing circuit can control the enable state of the MAX13330/MAX13331 directly and/or be sent into the digital input of an available microcontroller, depending on the application requirements.

DirectDrive is a registered trademark of Maxim Integrated Products, Inc.

---

### Related Parts

MAX13330: [QuickView](#) -- [Full \(PDF\) Data Sheet](#) -- [Free Samples](#)

MAX13331: [QuickView](#) -- [Full \(PDF\) Data Sheet](#) -- [Free Samples](#)

---

### Automatic Updates

Would you like to be automatically notified when new application notes are published in your areas of interest? [Sign up for EE-Mail™](#).

---

Application note 4607: [www.maxim-ic.com/an4607](http://www.maxim-ic.com/an4607)

### More Information

For technical support: [www.maxim-ic.com/support](http://www.maxim-ic.com/support)

For samples: [www.maxim-ic.com/samples](http://www.maxim-ic.com/samples)

Other questions and comments: [www.maxim-ic.com/contact](http://www.maxim-ic.com/contact)

---

AN4607, AN 4607, APP4607, Appnote4607, Appnote 4607

Copyright © by Maxim Integrated Products

Additional legal notices: [www.maxim-ic.com/legal](http://www.maxim-ic.com/legal)