

Keywords: bipolar dc-voltage detection, high-impedance inputs, galvanic isolation

Jan 26, 2011

APPLICATION NOTE 4568

## Bipolar DC-Voltage Detector Offers Sensitivity and Precision

**Abstract:** Comprised of two precision op amps (MAX4236), a voltage reference (MAX6143), a NAND gate, and associated components, this DC-voltage detector circuit asserts a digital output signal when the input is within a  $\pm 100\text{mV}$  window, centered at 0V.

A similar version of this article appeared in the June 1, 2007 issue of *Power Electronics Technology* magazine.

An important function in industrial and scientific applications is detecting the presence (or absence) of DC voltages in safety interlocks, automatic sequencers, etc. To detect the absence of large bipolar DC levels, the detector must assert a signal when its input is within a stable and precisely defined window around zero volts. The window width should be twice the maximum tolerable error voltage, and centered at zero volts.

The detection circuit must have a high-impedance input to avoid affecting the system into which it is inserted. It must also tolerate an input level equal to the the maximum voltage it supervises plus the amplitude of any transient that might appear. One circuit that meets those requirements (**Figure 1**) produces a digital output signal when the input voltage is within a  $\pm 100\text{mV}$  window.

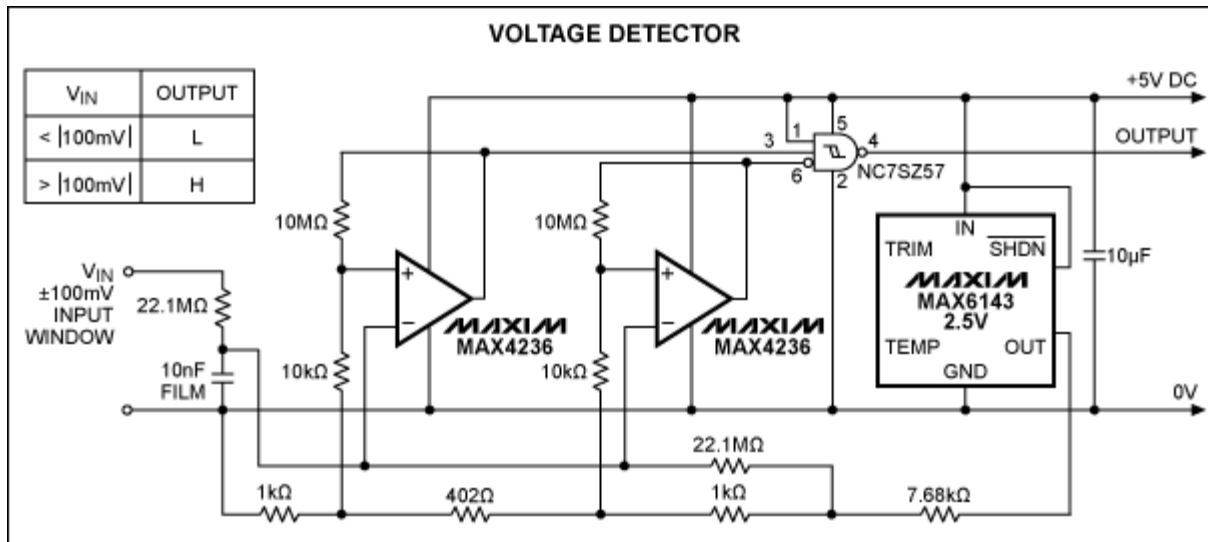
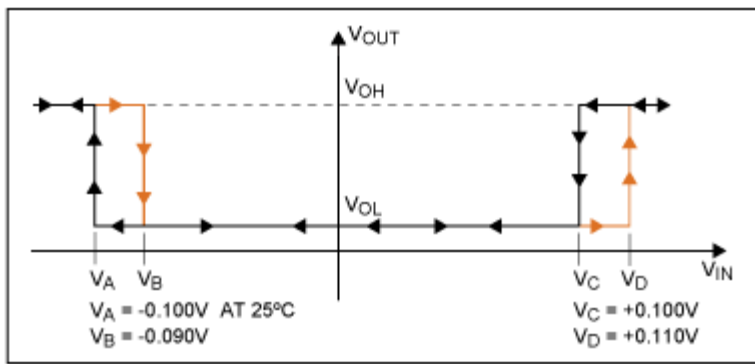
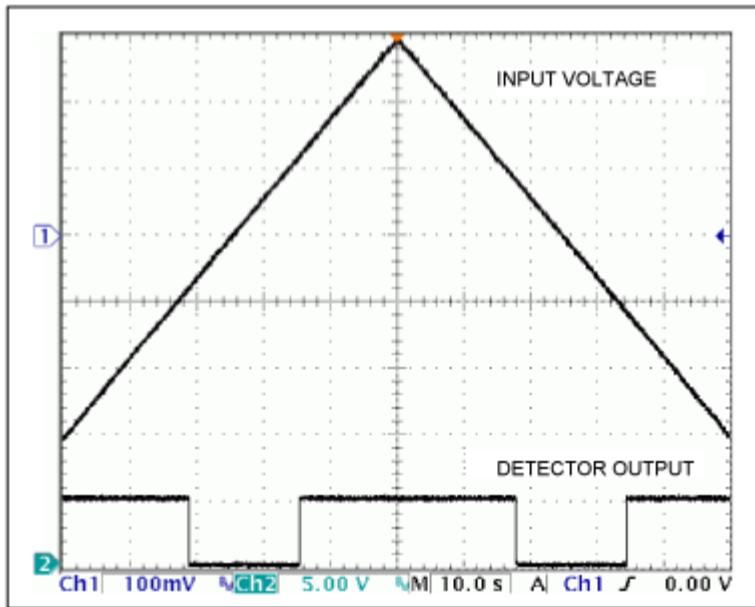

Figure 1. This detector of bipolar DC voltages asserts a digital output signal when the input is within a  $\pm 100\text{mV}$  window, centered at 0V.

Its input resistance is  $22\text{M}\Omega$ , and its maximum input voltage is defined by the arcing specification of the  $22.1\text{M}\Omega$  series input resistor. Its well-defined window edges have about  $10\text{mV}$  of hysteresis, which eliminates any noise-induced output chatter (**Figure 2**). Response speed is determined by a  $10\text{ms}$  time constant formed by the  $10\text{nF}$  input capacitor (a low-leakage film type) and the parallel combination (about  $11\text{M}\Omega$ ) of two  $22.1\text{M}\Omega$  input-voltage divider/shifter resistors.



(a)



(b)

Figure 2. These waveforms from the Figure 1 circuit show the response of the detector output to an input-voltage ramp.

The circuit operates from a single +5V supply, thanks to the ability of the op amp (MAX4236) to operate with low offset voltage, low offset-voltage tempco, low bias current, and input voltages that include the negative rail. Temperature dependence of the trigger thresholds is less than 1mV (total) over the range 0°C to +85°C. To ensure stability of these trigger voltages over temperature, the tempcos of the two 22.1MΩ resistors should be low and as closely matched as possible.

Very high input impedance makes this circuit sensitive to leakage currents. The negative input of each op amp must be supported by a teflon standoff, and a high-quality conformal-coating insulation should be applied to the whole assembly. If the detector circuit must be galvanically isolated from the system-control circuitry, consider the circuit of Figure 3. Data sheets and other information on the ICs shown in these figures can be found at [www.maxim-ic.com/](http://www.maxim-ic.com/).

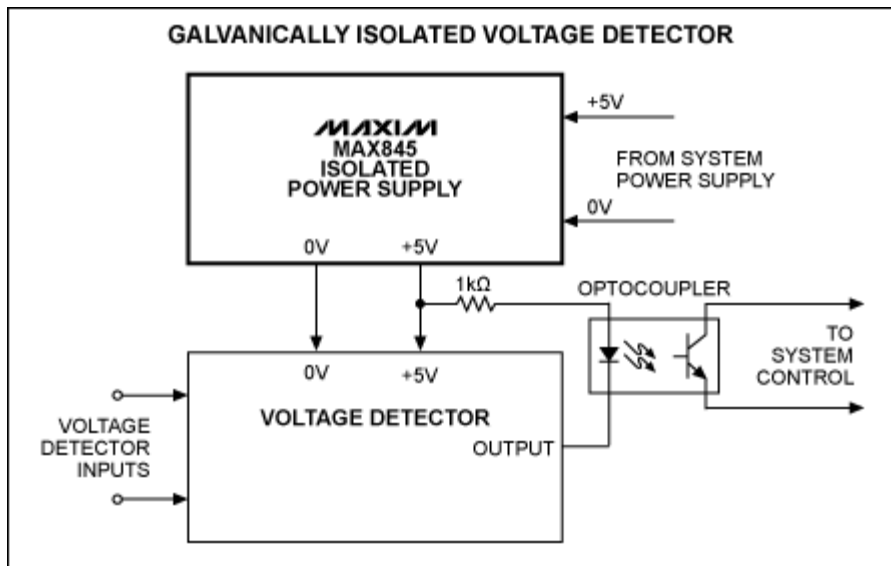

Figure 3. Modified as shown, the Figure 1 output signal is galvanically isolated from the monitored voltage.

### Related Parts

- MAX4236** SOT23, Very High Precision, 3V/5V Rail-to-Rail Op Amps -- [Free samples](#)
- MAX6143** High-Precision Voltage Reference with Temperature Sensor -- [Free samples](#)
- MAX845** Isolated Transformer Driver for PCMCIA Applications -- [Free samples](#)

### Automatic Updates

Would you like to be automatically notified when new application notes are published in your areas of interest? [Sign up for EE-Mail™](#).

### More Information

For technical support: <http://www.maxim-ic.com/support>  
 For samples: <http://www.maxim-ic.com/samples>  
 Other questions and comments: <http://www.maxim-ic.com/contact>

Application note 4568: <http://www.maxim-ic.com/an4568>  
 AN4568, AN 4568, APP4568, Appnote4568, Appnote 4568  
 Copyright © by Maxim Integrated Products  
 Additional legal notices: <http://www.maxim-ic.com/legal>