

APPLICATION NOTE 4533

# An LED Target-Practice Game Uses the MAXQ2000 and MAX7312

By: Gordon Lee

*Abstract: This application note is an LED target-practice game. The game demonstrates the capabilities of the MAXQ2000 microcontroller (MAXQ20 core) and the MAX7312 port expander. All the firmware required to interface the two devices is provided.*

## Introduction

This application note provides all the firmware required to interface the [MAXQ2000](#) microcontroller (MAXQ20 core) to the [MAX7312](#) 16-bit port expander. The application example is an LED target-practice game. The example assembly program was written and assembled specifically for the MAXQ2000 using the free [IAR Embedded Workbench®](#) IDE version 2.10A.

## Hardware Overview

The MAX7312 is a 2-wire-interfaced 16-bit I/O port expander with interrupt and hot-insertion protection. Using this application note and a [MAX7312 EV \(evaluation\) kit](#), the user can create an LED target-practice game. The EV kit's red and green LEDs will quickly roll up and down. The game's objective is to press one of the pushbuttons when the red and green LED lights meet at the center.

The MAX7312 EV kit consists of the MAX7312, the MAXQ2000 microcontroller, all required passive components, and a proven PCB layout. The MAX7312 EV kit schematics are shown in **Figures 1** and **2**.

For more information on the MAXQ2000 microcontroller, please order the [MAXQ2000 EV kit](#). The MAXQ2000 EV kit contains a complete set of software, hardware, sample code, and documentation needed to start designing with MAXQ2000. Schematics for the MAXQ2000 EV kit are available in the data sheet.

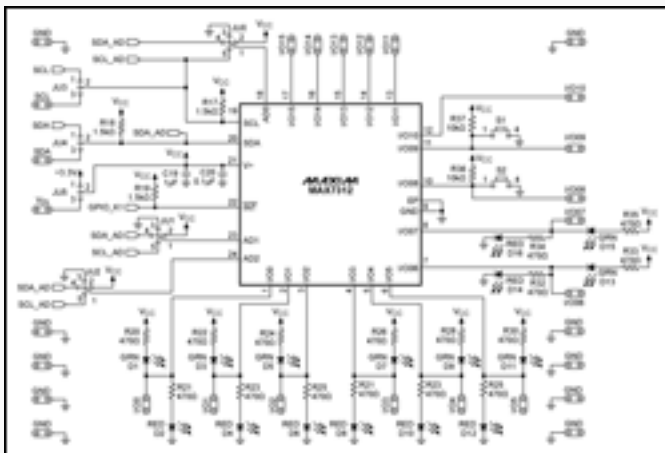

[More detailed image](#) (PDF, 292kB)

Figure 1. The MAX7312EV kit schematic, one of two schematics.

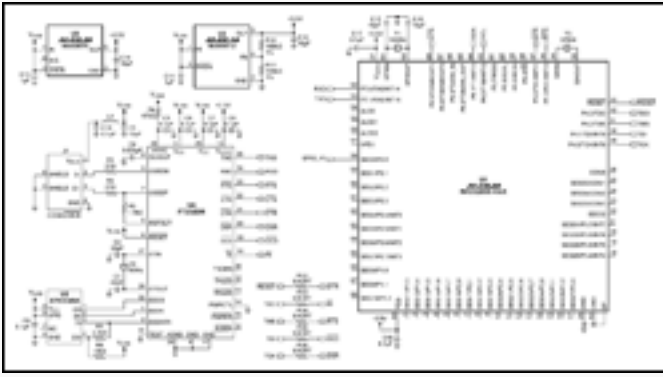

[More detailed image](#) (PDF, 332kB)

Figure 2. MAX7312EV kit schematic, second of two schematics.

## Firmware Overview

The example firmware program (see below) communicates to the MAX7312 by bit-banging an I<sup>2</sup>C interface on the MAXQ2000's general-purpose input/output (GPIO) ports. The MAXQ2000's 20MHz system clock allows the bit-banged I<sup>2</sup>C interface to run at up to 400kHz. The user modifies the `maxqi2c.h` header file to select the speed of the I<sup>2</sup>C interface and which GPIO ports will be used as SDA and SCL. Please refer to application note 3588, "[Software I<sup>2</sup>C Driver for the MAXQ2000 Microcontroller](#)," for more information.

Once the MAX7312 EV kit is powered on, the MAXQ2000 automatically detects the I<sup>2</sup>C address of the MAX7312. The program then starts to configure the MAX7312's port 1 GPIOs to create the LED lights' rolling effect. The port 2 GPIOs 8 and 9 are configured as input ports, and the firmware reads the states of the pushbuttons through those ports.

The game challenges the player to press a pushbutton when the red and green LED scrolling lights meet at the center. If the button is pressed when the LEDs meet, then MAXQ2000 microcontroller will detect it and all LEDs will flash indicating that the user wins the game.

**Table 1** shows all of the I<sup>2</sup>C operations that are needed for this game application.

**Table 1. I<sup>2</sup>C Operations**

I <sup>2</sup> C/SMBus Protocol	Application Purpose	Device Slave Address	Register Address
Read port 2 input register	Read the states of the pushbuttons	0x40	0x01
		01000000b	00000001b
Write configuration registers to port 1	Configure the I/O direction for port 1	0x40	0x06
		01000000b	00000110b
Write configuration registers to port 2	Configure port 2 GPIOs 8 and 9 as input ports	0x40	0x07
		01000000b	00000111b
Write output port register to port 1	Turn LED lights on or off	0x40	0x02
		01000000b	00000010b

The source code for this application is available for [download](#).

IAR is a trademark of IAR Systems AB.

## Related Parts

MAX7312: [QuickView](#) -- [Full \(PDF\) Data Sheet](#) -- [Free Samples](#)

---

**Automatic Updates**

Would you like to be automatically notified when new application notes are published in your areas of interest?  
[Sign up for EE-Mail™](#).

---

Application note 4533: [www.maxim-ic.com/an4533](http://www.maxim-ic.com/an4533)

**More Information**

For technical support: [www.maxim-ic.com/support](http://www.maxim-ic.com/support)

For samples: [www.maxim-ic.com/samples](http://www.maxim-ic.com/samples)

Other questions and comments: [www.maxim-ic.com/contact](http://www.maxim-ic.com/contact)

---

AN4533, AN 4533, APP4533, Appnote4533, Appnote 4533

Copyright © by Maxim Integrated Products

Additional legal notices: [www.maxim-ic.com/legal](http://www.maxim-ic.com/legal)