

APPLICATION NOTE 4485

Derive Simple High-Current Source from Lab Supply

Abstract: Comprising a standard Force-Sense lab power supply, an additional power supply for the ICs, and a separate control voltage, this adjustable current source provides a 1-to-1 ratio of control voltage to load current (1A/V).

A similar version of this article appeared in the October 16, 2008 issue of *EDN* magazine.

When electronic testing requires an adjustable current source, you must often build that piece of test equipment in the lab. You can easily make such a current source from a standard Force-Sense lab power supply (Figure 1). The circuit requires an additional power supply for the integrated circuits, and a separate control voltage.

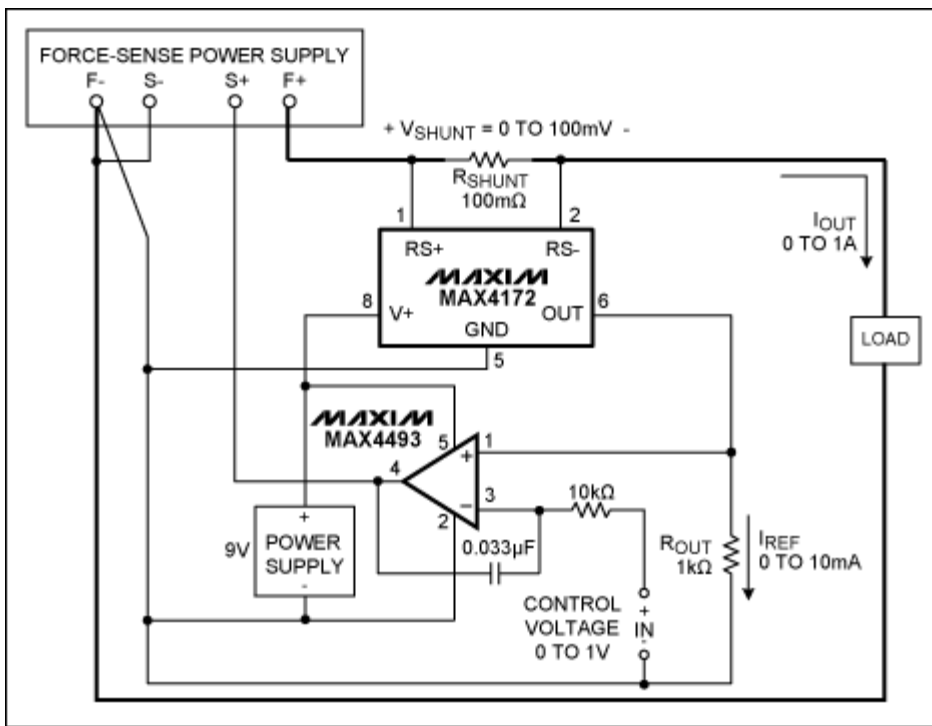

Figure 1. Adding these components to a standard Force-Sense lab supply makes a simple voltage-controlled current source. As configured, the circuit produces a control ratio of 1:1 amperes per volt.

The feedback signal to the Force-Sense supply is derived from a high-side current monitor ([MAX4172](#)). In the configuration shown, the circuit offers a 1-to-1 ratio of control voltage to load current (1A/V). Load current as a function of load resistance is shown in Figure 2.

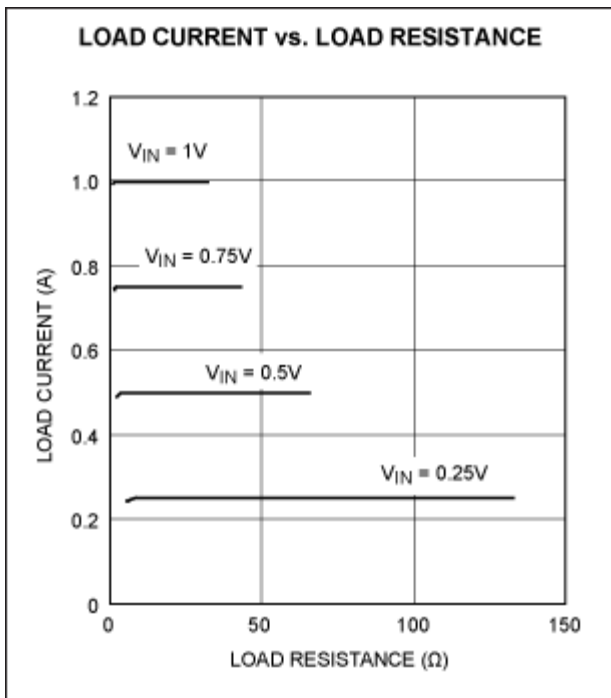

Figure 2. Load current vs. load resistance for the Figure 1 circuit.

To change the voltage/current ratio, simply change R_{SHUNT} : a lower value of R_{SHUNT} gives higher current, and vice-versa. Output current is limited by the maximum allowed voltage (150mV) between the $RS+$ and $RS-$ terminals, the maximum $RS+$ voltage (32V), and of course, the maximum current capability of the Force-Sense supply.

Because voltage and current meters built into the Force-Sense supply will display inaccurate values while this circuit is operating, you should use external meters to monitor the load voltage and load current. Also, be aware that if the load is removed ($I_{OUT} = 0$), the open-circuit voltage of the Force-Sense supply goes to the maximum value it can generate.

Related Parts

[MAX4172](#) Low-Cost, Precision, High-Side Current-Sense Amplifier

-- [Free Samples](#)

[MAX4493](#) SC70, Low-Power, General-Purpose, Dual-Supply, Rail-to-Rail Op Amps -- [Free Samples](#)

Automatic Updates

Would you like to be automatically notified when new application notes are published in your areas of interest? [Sign up for EE-Mail™](#).

Application note 4485: www.maxim-ic.com/an4485

More Information

For technical support: www.maxim-ic.com/support

For samples: www.maxim-ic.com/samples

Other questions and comments: www.maxim-ic.com/contact

AN4485, AN 4485, APP4485, Appnote4485, Appnote 4485

Copyright © by Maxim Integrated Products

Additional legal notices: www.maxim-ic.com/legal