



APPLICATION NOTE 4451

MAX2170 S11 Data for VHF and L-Band Input

By: Scott Anderson

Abstract: This application note shows how the MAX2170 triple-band (T-DMB, DAB, FM) receiver's input-scattering parameter (S11) is measured for the VHF and L-band inputs.

Overview

The [MAX2170](#) direct conversion to low-IF tuner has an input scattering parameter (S11), which is measured for the VHF and L-band inputs. The calibration plane is at the pin of the IC.

The VHF input consists of a bandpass tracking filter followed by an LNA. The return loss will be good for the desired channel, but will look reflective for the out-of-band channels. As a result, the S11 data will change significantly as the MAX2170 tunes to a new channel. To address this issue, the series 91nH inductor, which is part of the VHF tracking filter, was removed from the input for the S11 measurements (**Figure 1**). Removing this component changes the tracking filter's shape but allows S11 calibration to the pin of the IC. Note, however, that the 91nH inductor is required for the tracking filter to operate properly. It must be used in the final application.

The L-band input consists of ESD diodes and an LNA. The input will look resistive with some shunt capacitance. The S11 data for this input will not vary when the MAX2170 tunes to a new channel. The L-band input can be modeled as a resistor $R = 23.4\Omega$ in series with $C = 4.2\text{pF}$.

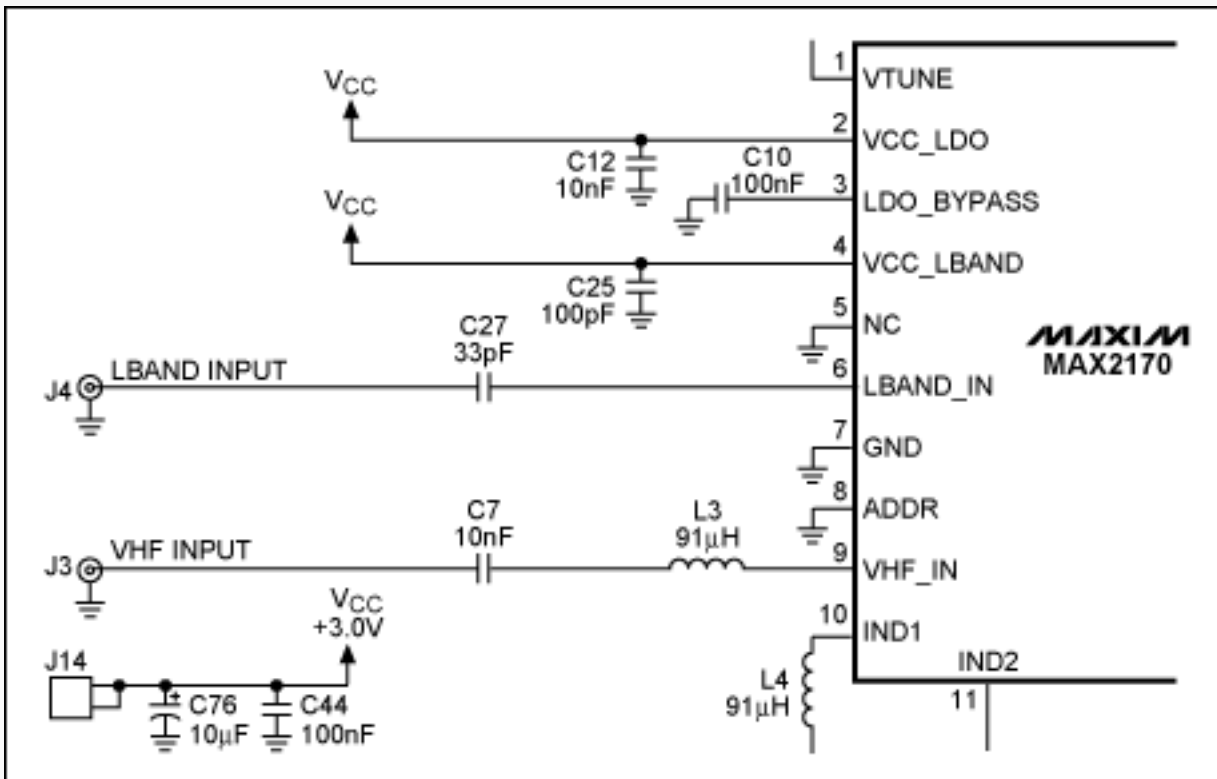

Figure 1. Schematic of the VHF and L-band inputs to the MAX2170. The 91nH inductor for the VHF input can be removed for calibration of S11 data.

Performance Summary

Table 1 shows S11 data (magnitude and phase) for the VHF and L-band inputs. The RF frequency is changed for each measurement.

Table 1. S11 (Magnitude/Phase) for VHF and L-Band Input

Band	Channel	Frequency (MHz)	Pin = -50dBm	
			Mag	Phase
VHF	5A	174.928	0.690	-39.2
	9B	204.64	0.729	-31.6
	13F	239.2	0.776	-26.1
L	LA	1452.96	0.503	-115.4
	LL	1471.792	0.479	-116.9
	LW	1490.624	0.459	-117.1

Table 2 shows S11 data (real and imaginary) for the VHF and L-band inputs. The RF frequency is changed for each measurement.

Table 2. S11 (Real/Imaginary) for VHF and L-Band Inputs

Band	Channel	Frequency (MHz)	Pin = -50dBm	
			Real	Imaginary
VHF	5A	174.928	5.35E-01	-4.37E-01
	9B	204.64	6.21E-01	-3.83E-01
	13F	239.2	6.97E-01	-3.41E-01
L	LA	1452.96	-2.15E-01	-4.55E-01
	LL	1471.792	-2.17E-01	-4.27E-01
	LW	1490.624	-2.09E-01	-4.09E-01

Test Results

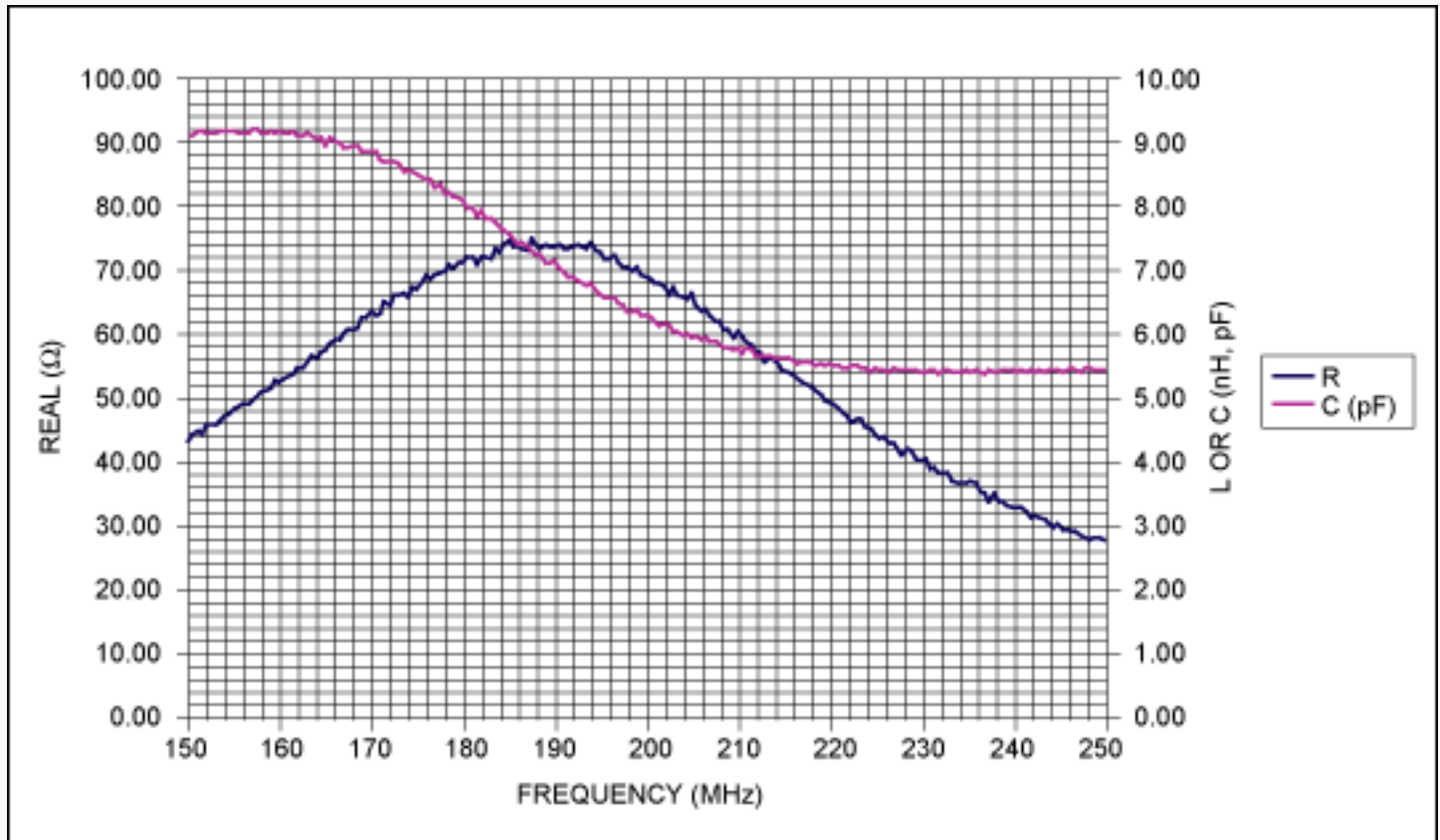

Figure 2. The Thevenin equivalent resistance and capacitance for the VHF input when the RF is tuned to 174.928MHz.

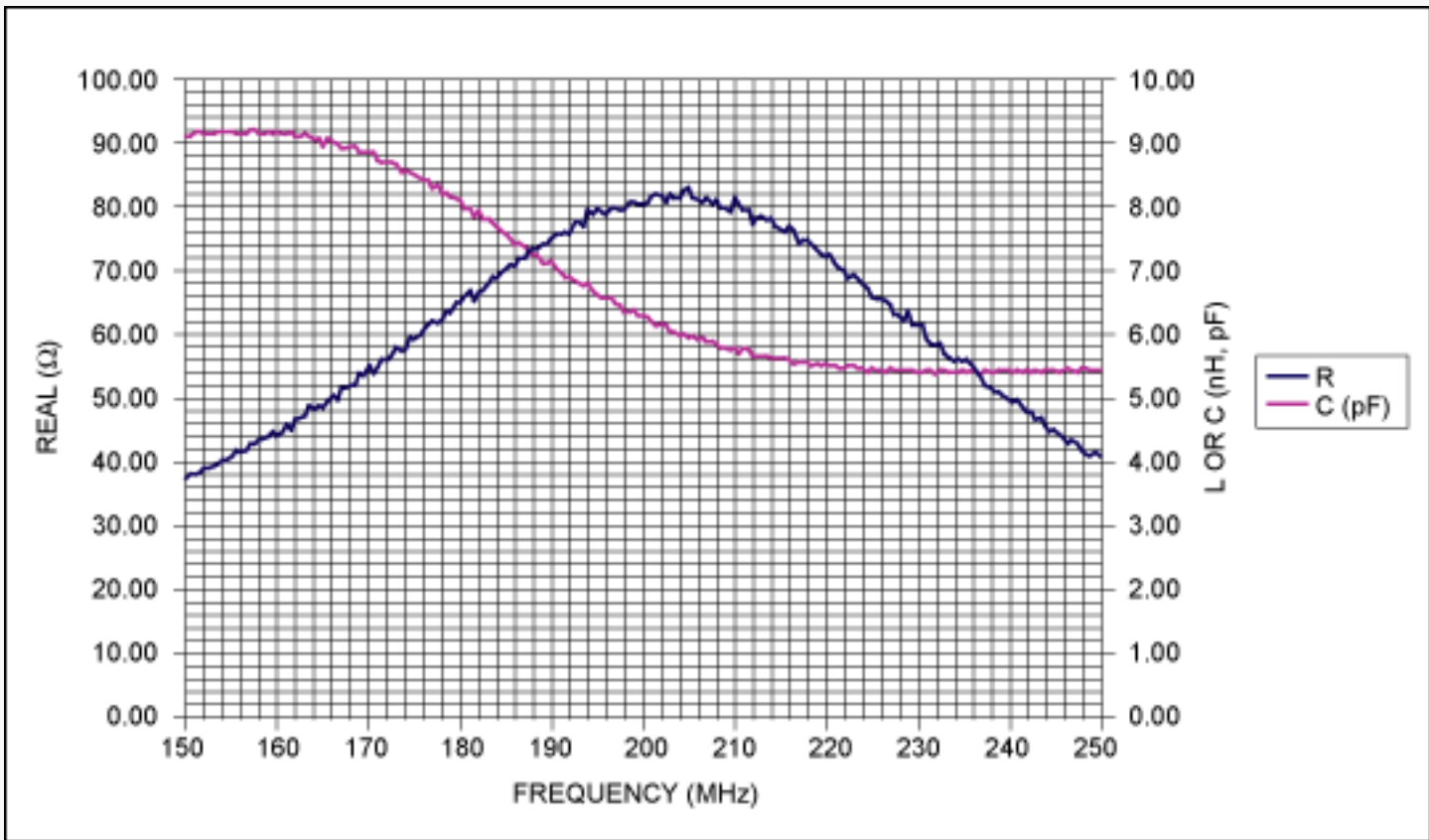

Figure 3. The Thevenin equivalent resistance and capacitance for the VHF input when the RF is tuned to 204.64MHz.

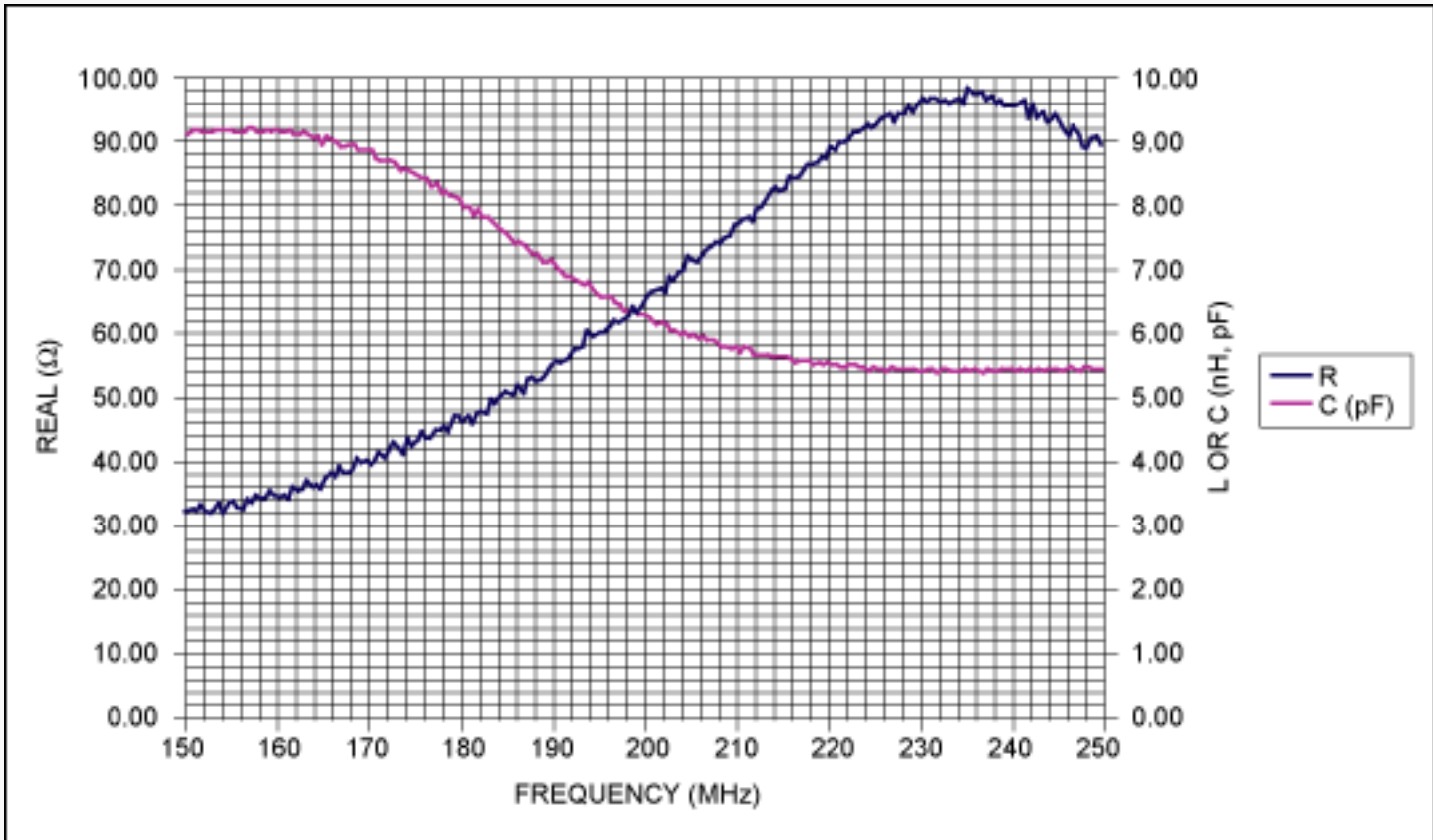

Figure 4. The Thevenin equivalent resistance and capacitance for the VHF input when the RF is tuned to 239.2MHz.

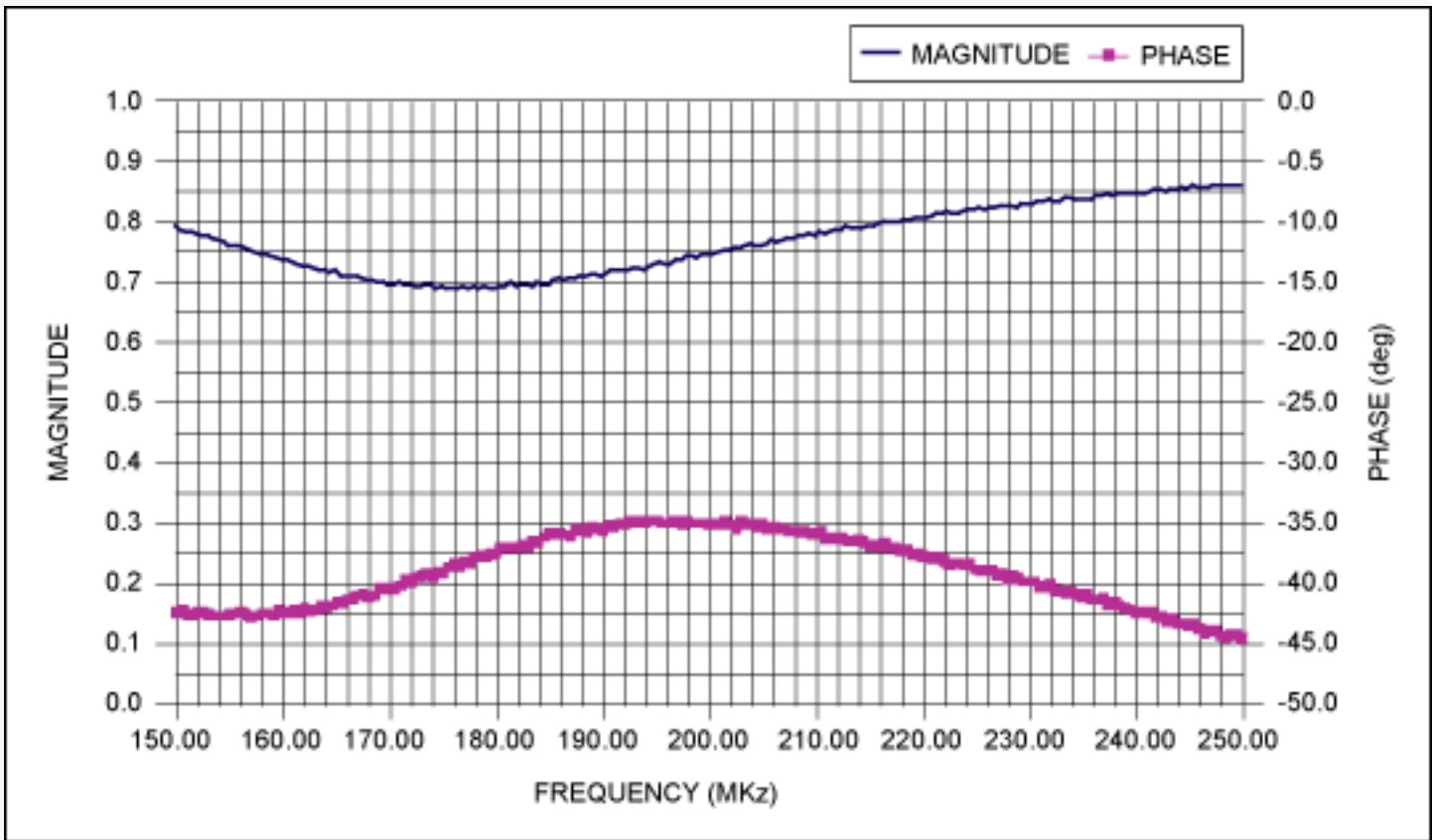

Figure 5. S11 magnitude and phase for the VHF input with the MAX2170 tuned to 174.928MHz. Note that this s-parameter data will change if the MAX2170's RF frequency changes.

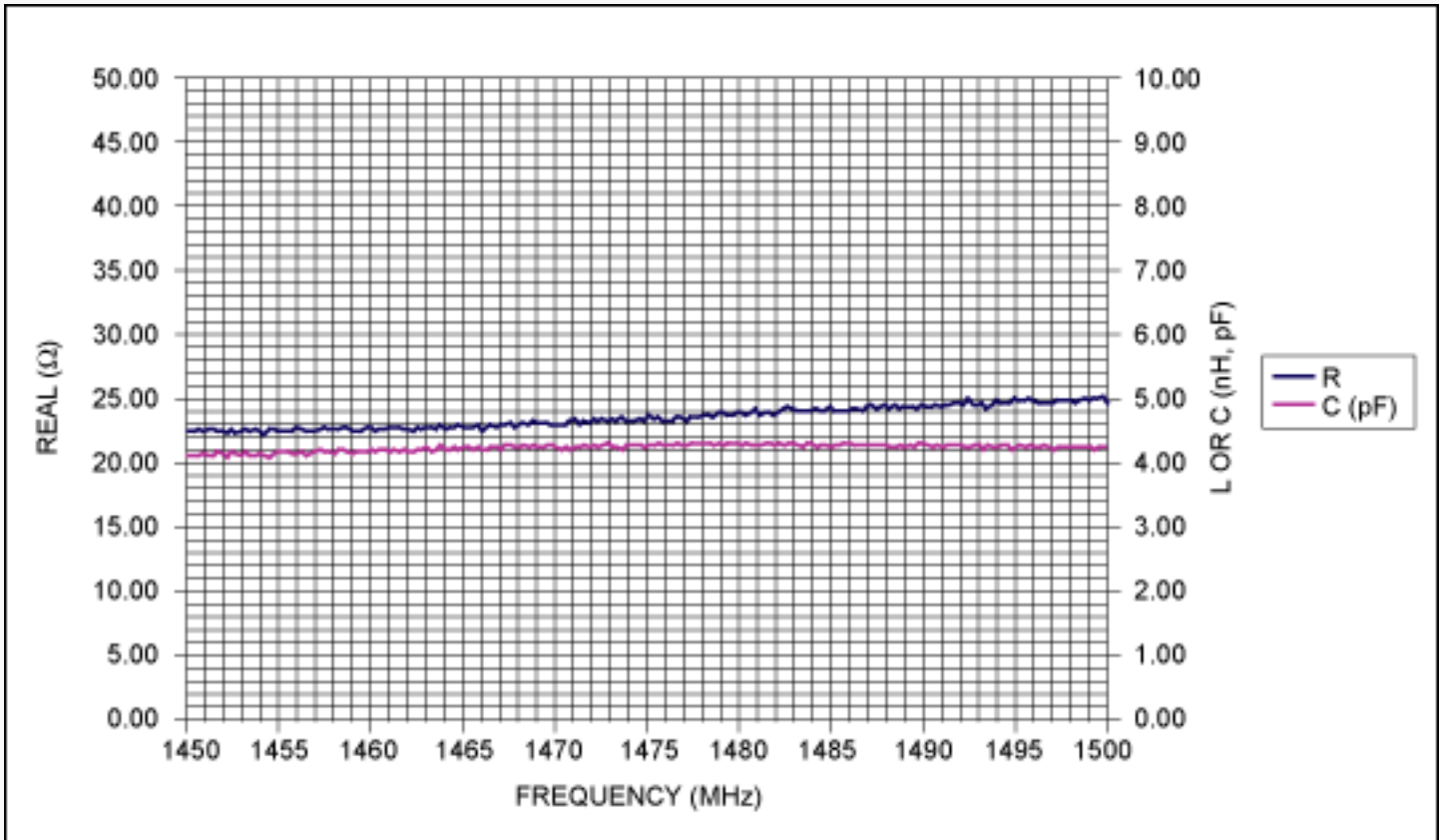

Figure 6. The Thevenin equivalent resistance and capacitance for the L-band input. The Thevenin equivalent circuit looks the same for RF frequencies from 1450MHz to 1500MHz. The average value is $R = 23.4\Omega$ in series with $C = 4.2\text{pF}$.

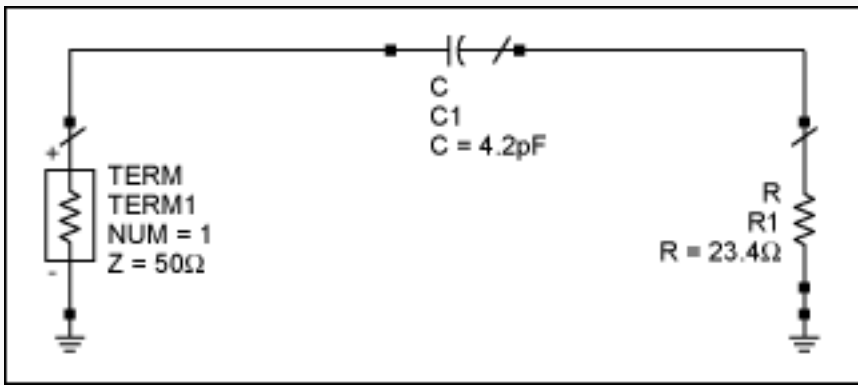

Figure 7. The Thevenin model of L-band RF input in a 50Ω system

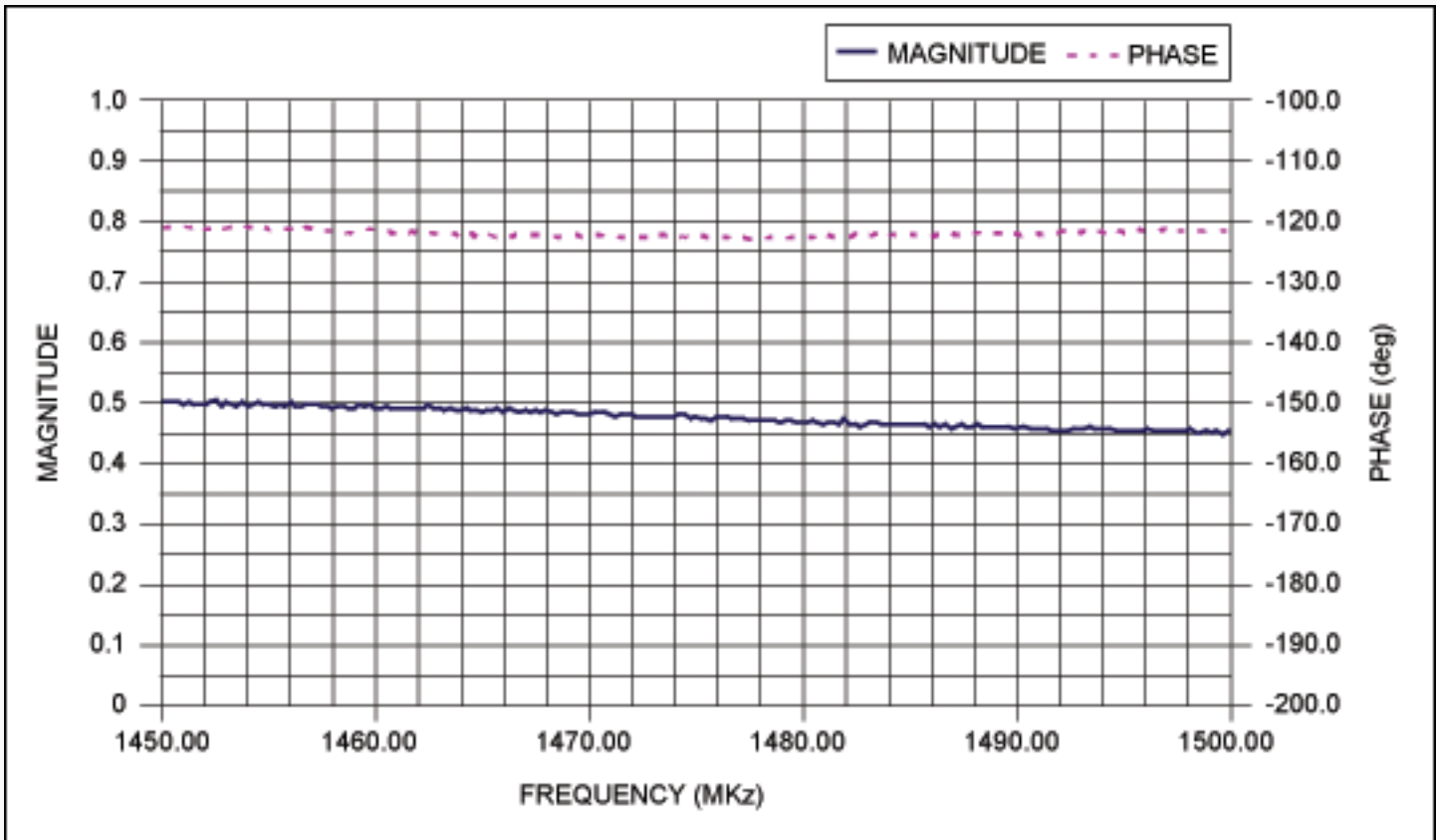

Figure 8. S11 magnitude and phase for the L-band input.

Test Files

The following test files contain S11 data in CITIFILE format for the MAX2170.

File	Description
VHF_174.928.d1	VHF input with RF tuned to 174.928MHz
VHF_204.64.d1	VHF input with RF tuned to 204.64MHz
VHF_239.2.d1	VHF input with RF tuned to 239.2MHz
L_5A.d1	L-band input with RF tuned to 1452.96MHz
L_9B.d1	L-band input with RF tuned to 1471.792MHz
L_13F.d1	L-band input with RF tuned to 1490.624MHz

Application note 4451: www.maxim-ic.com/an4451

More Information

For technical support: www.maxim-ic.com/support

For samples: www.maxim-ic.com/samples

Other questions and comments: www.maxim-ic.com/contact

Automatic Updates

Would you like to be automatically notified when new application notes are published in your areas of interest?

[Sign up for EE-Mail™](#).

AN4451, AN 4451, APP4451, Appnote4451, Appnote 4451

Copyright © by Maxim Integrated Products

Additional legal notices: www.maxim-ic.com/legal