

APPLICATION NOTE 4416

IC Forms Direct-Readout Temperature Probe

By: Bich Pham

Abstract: This application note describes a simple circuit that serves as a temperature measurement probe. The probe measures temperature either at the probe tip or on a PC board to which the temperature sensor is attached. The circuit is described and data presented. The MAX6610 temperature sensor is featured in the design.

This design idea appeared in the February 2, 2006 issue of *EDN* magazine.

The simple temperature-measurement probe of **Figure 1** can be an indispensable tool for troubleshooting and debugging electronic circuits. It reads temperatures either at the probe tip or on a board to which the IC (here, the [MAX6610](#) temperature sensor) is attached. Resistors R1–R3 let you scale the output to various values like those shown in **Table 1**.

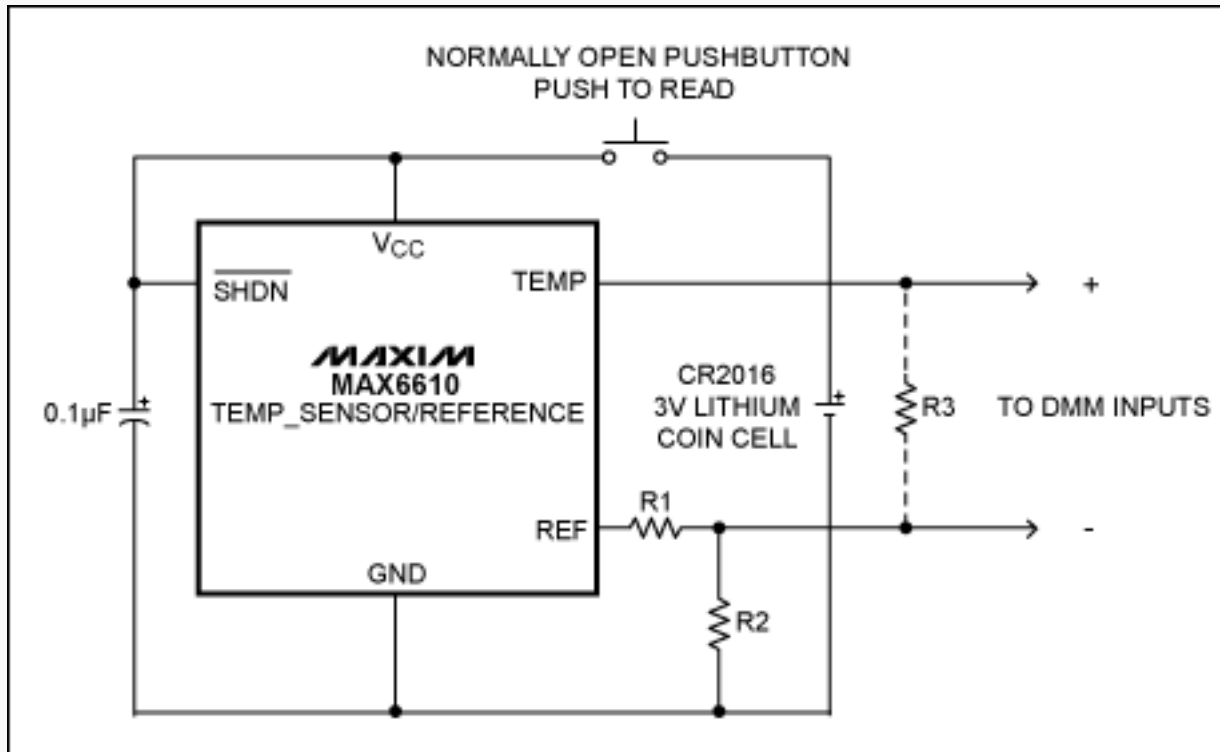

Figure 1. A simple temperature-sensing circuit.

Table 1. Resistor* Values for Different DMM Readout Scales

	10mV/°C	1mV/°C	1mV/°F
R1	68.1kΩ	68.1kΩ	68.1kΩ
R2	28kΩ	28kΩ	19.6kΩ
R3	Open	2.21kΩ	3.32kΩ

*All resistors ±1% tolerance.

Any digital voltmeter or handheld digital multimeter can serve as a readout. The required supply voltage is

approximately 3V, so a suitable power source would be two AA alkaline cells or a lithium coin-type cell. The typical supply current is about 0.2mA. A CR2016-type cell can operate the circuit continuously for several hundred hours, or for several years if the circuit is equipped with a normally open pushbutton as shown.

The output voltage vs. temperature (**Figure 2**) was compared with that of a platinum-resistance standard thermometer in an oil bath to produce the error curve shown in **Figure 3**. More information on measurement error and output range can be found in the MAX6610 data sheet.

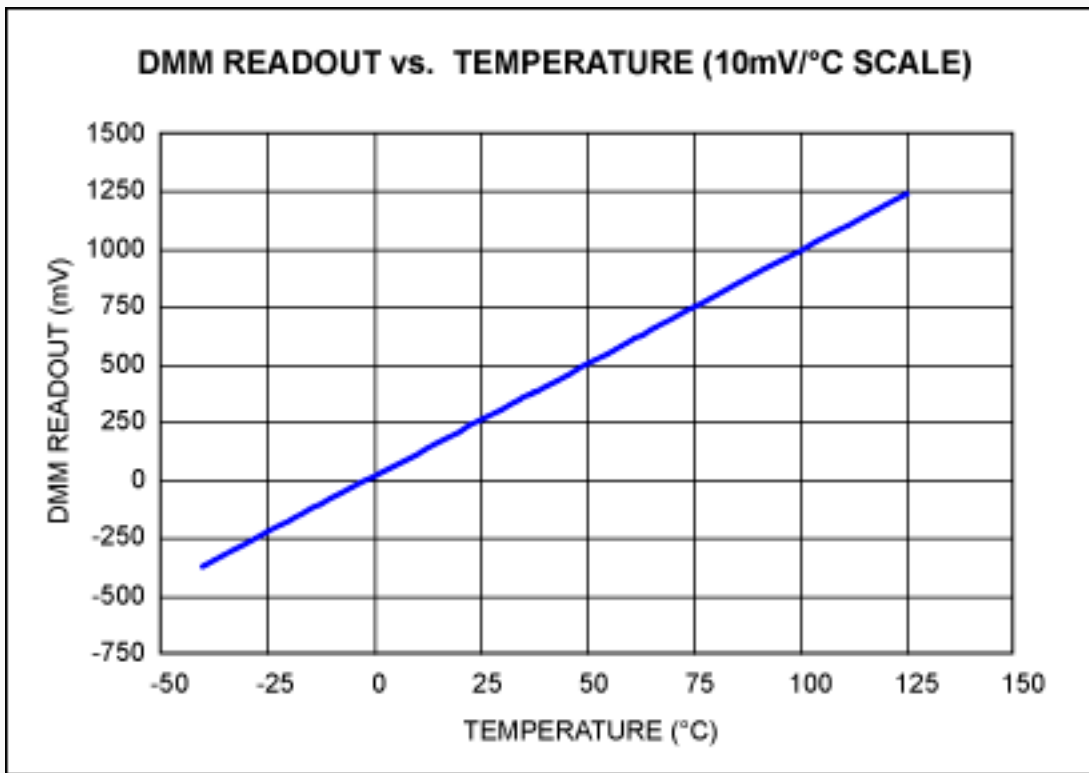

Figure 2. Output voltage vs. temperature for the circuit of Figure 1. Note: Scale factor = 10mV/°C.

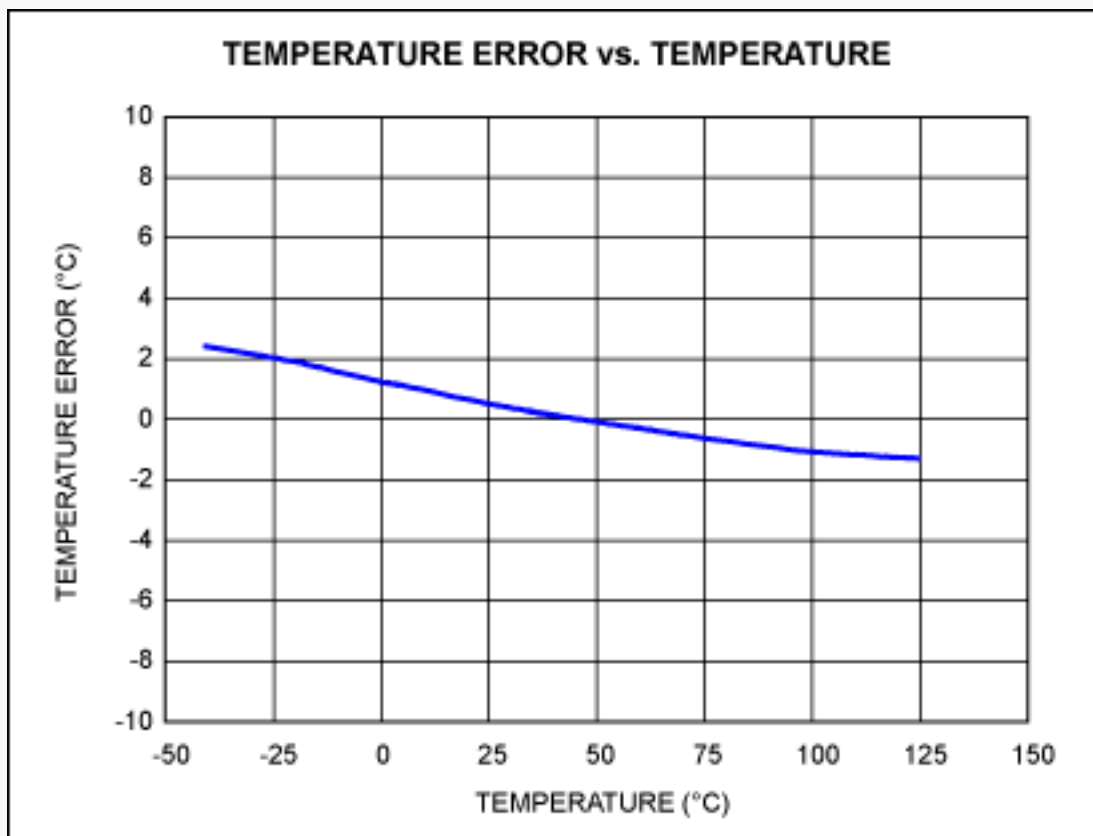

Figure 3. Temperature error for the Figure 1 circuit, with respect to a platinum-resistance standard thermometer in an oil bath. The circuit exhibits $\pm 2^{\circ}\text{C}$ error over -40°C to $+125^{\circ}\text{C}$.

To use the circuit as a probe, build a probe tip of copper wire 1mm in diameter and about 5mm long. Solder it directly to a small PC pad right at the GND pin of the IC. The wire should touch the GND pin. For mechanical support, you can also glue the wire to the PC board. (The idea is to use copper wire as a path of low thermal resistance from the IC to the point being probed.) To minimize heat loss from probe to board (heat loss affects the temperature-measurement accuracy), use long thin copper lines as electrical connections to the IC.

Requirements for a board-temperature sensor are somewhat opposite to those for a temperature probe. For board-temperature sensing, the IC must be in intimate thermal contact with the board. Connect large copper areas immediately at the IC pins (i.e., short thick lines or no lines at all between the copper islands and the IC). By providing thermal contact with the board, the copper areas guarantee good heat transfer and accurate temperature readings between board and sensor.

Related Parts

MAX6610: [QuickView](#) -- [Full \(PDF\) Data Sheet](#)

Automatic Updates

Would you like to be automatically notified when new application notes are published in your areas of interest? [Sign up for EE-Mail™](#).

Application note 4416: www.maxim-ic.com/an4416

More Information

For technical support: www.maxim-ic.com/support

For samples: www.maxim-ic.com/samples

Other questions and comments: www.maxim-ic.com/contact

Additional legal notices: www.maxim-ic.com/legal