

APPLICATION NOTE 4406

Power Supply Features Low V_{IN} and V_{OUT}

By: John Guy

Abstract: The MAX1708 DC-DC converter is featured in a circuit that boosts 1.2V to 1.6V with > 78% efficiency.

This design idea appeared in the May 5, 2006 issue of *Portable Design* magazine.

The operating voltages for today's ASICs and microprocessors are substantially lower than those of a few years ago, which creates problems for power-supply designers. Particularly difficult is the derivation of low output voltages from a single NiCad, NiMH, or alkaline cell. Off-the-shelf circuits are available for output voltages above 2V, but none for V_{OUT} below 2V.

One way around this limitation is shown in **Figure 1**. Adding a few components to the standard application circuit for the [MAX1708](#), a DC-DC step-up switching converter, boosts a nominal 1.2V input to a 1.6V output voltage. The added components are a triple Schottky diode (D2) and two charge-pump capacitors (C7 and C8). The input and output capacitors (C1–C4), inductor (L1), and main rectifier (D1) are selected according to equations in the MAX1708 data sheet.

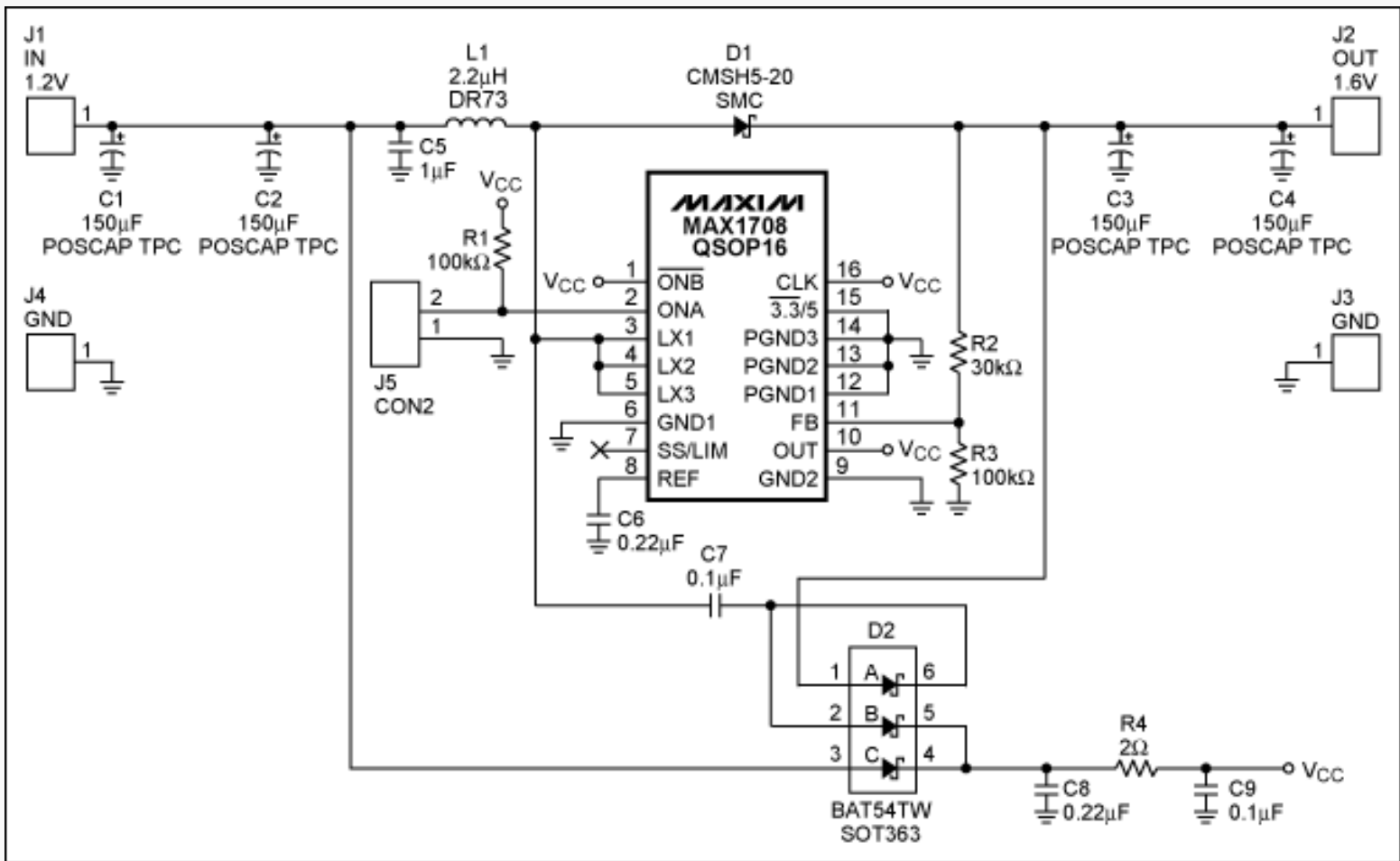

Figure 1. This circuit features the MAX1708 DC-DC converter, and boosts 1.2V to 1.6V with > 78% efficiency.

During normal operation, the LX node of the MAX1708 switches through about 2.1V, going from ground up to V_{OUT} plus one diode drop. The LX node also drives diodes D2A and D2B to form a voltage-doubling charge pump. With the components shown and for V_{IN} ranging from 0.8V to 1.5V, this output voltage is 3.30V. Filtered through R4 and C9, it serves as a well-regulated and well-filtered operating voltage. The MAX1708 is in its normal operating mode at startup, but the bootstrap

voltage comes from diode D2C. When V_{OUT} approaches regulation, the main charge pump takes over and provides the full operating voltage.

With the components shown, over 900mA of output current is available and the operating efficiency is as high as 78% (**Figure 2**). The circuit delivers output currents from 1mA to 300mA. After starting, it continues operating until the battery is fully discharged, because the MAX1708 is powered from the bootstrapped output voltage. The actual startup voltage is a function of load impedance (**Figure 3**).

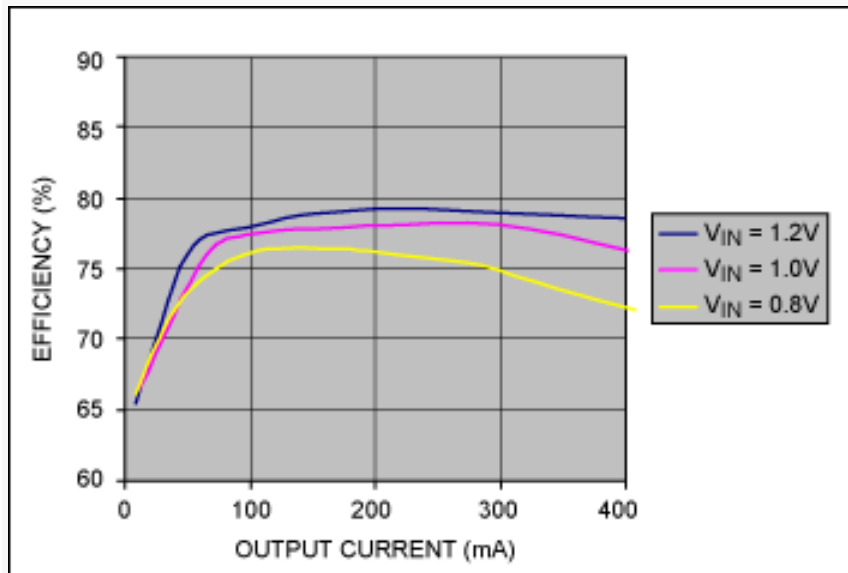

Figure 2. Efficiency remains high across a wide range of output current.

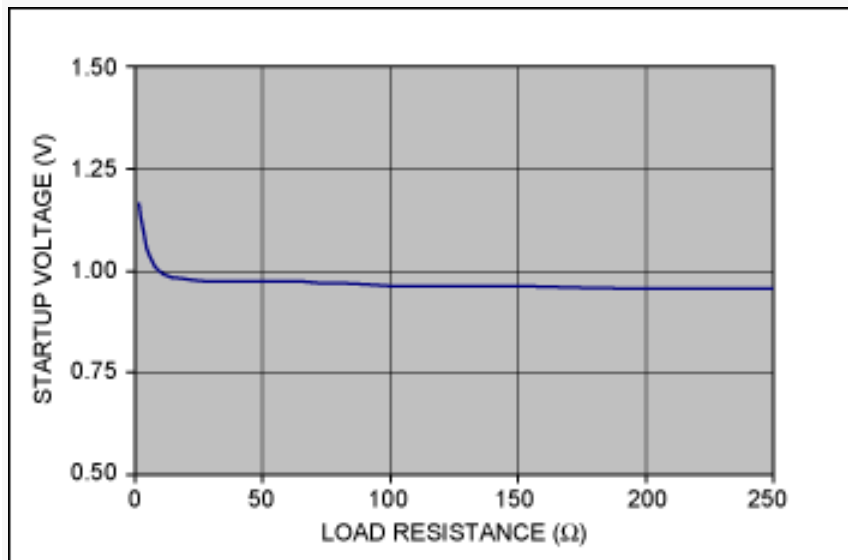

Figure 3. The circuit's startup voltage depends somewhat on load resistance.

Related Parts

MAX1708: [QuickView](#) -- [Full \(PDF\) Data Sheet](#) -- [Free Samples](#)

Automatic Updates

Would you like to be automatically notified when new application notes are published in your areas of interest? [Sign up for EE-Mail™](#).

Application note 4406: www.maxim-ic.com/an4406

More Information

For technical support: www.maxim-ic.com/support

For samples: www.maxim-ic.com/samples

Other questions and comments: www.maxim-ic.com/contact

AN4406, AN 4406, APP4406, Appnote4406, Appnote 4406

Copyright © by Maxim Integrated Products

Additional legal notices: www.maxim-ic.com/legal