



APPLICATION NOTE 439

Interfacing the MAX187 to the TMS320C3X Evaluation Module

Abstract: This application note describes how to interface the MAX187 to the TMS320C3X DSP EV module. This app note can also be used as an example to interface other Maxim ICs to the TMS320 EV module. Example assembly code is provided.

Overview

The MAX187 12-bit ADC can be interfaced to Texas Instruments' TMS320C30 DSP via serial interface. The interface uses three wires plus ground. This application note explains how to interface the MAX187 Evaluation Kit to the TMS320C3X Evaluation Module.

The example program was assembled using the TMS320C3X/4X COFF Assembler Version 4.50 and the TMS320C3X/4F COFF Linker Version 4.50 (the assembler and linker are copyright 1987-1992 Texas Instruments Incorporated).

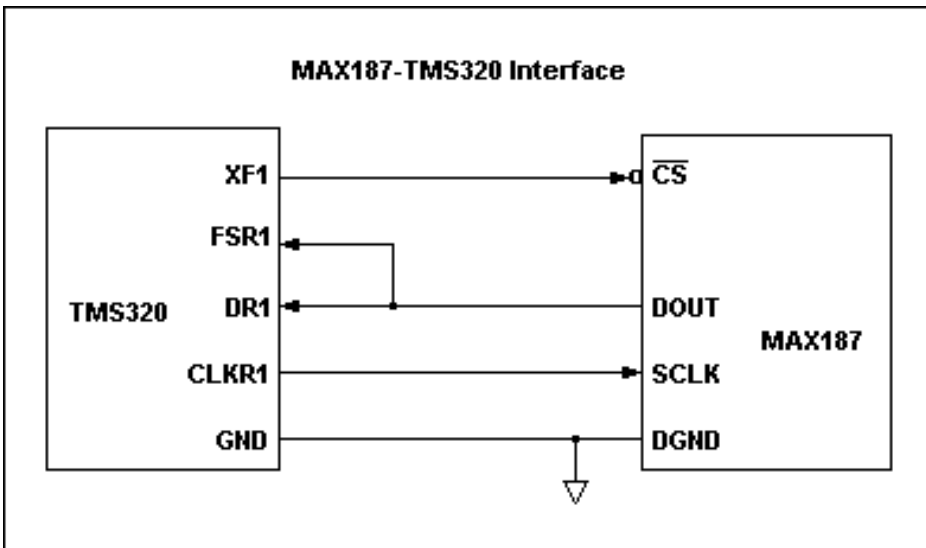

Figure 1. MAX187-TMS320 interface.

2. Connect a +5V power supply to the MAX187.
3. Use a 10-pin ribbon cable to connect the TMS320C3X EVM to the MAX187EVKIT.
4. Run the demo software.

Ribbon-Cable Signals

Pin	Max187	TMS320	Pin	Max187	TMS320
1	DGND	GND	2	DOUT	FSR1
3	Not used		4	DOUT	DR1
5	Not used		6	Not used	
7	Not used		8	CS	XF1
9	SCLK	CLKR1	10	DGND	GND

How It Works

The demo software configures the TMS320C30 so that FSR1 and DR1 are inputs and CLKR1 and XF1 are outputs. The software uses the XF1 output to initiate a conversion. The XF1 pulse drives the MAX187 chip-select input. The CLKR1 output provides the serial clock to the MAX187. Data output from the MAX187 is received on the DR1 input. The FSR1 Frame Start signal is also tied to the data output, so that the start bit from the MAX187 marks the beginning of the serial frame.

To read the MAX187, the software drives the XF1 output low and then waits 10µsec to allow time for the conversion. Then, the software enables the serial receive clock. The MAX187 sends its start bit, followed by the serial data. The demo software polls the serial receiver until a complete frame has been received. Because only 12 of the 16 bits are significant, the demo software right-justifies the significant bits and removes the start bit; then it writes the 12-bit word to the EVM host data port.

Application Note 439: <http://www.maxim-ic.com/an439>

More Information

For technical questions and support: <http://www.maxim-ic.com/support>

For samples: <http://www.maxim-ic.com/samples>

Other questions and comments: <http://www.maxim-ic.com/contact>

Related Parts

MAX187: [QuickView](#) -- [Full \(PDF\) Data Sheet](#) -- [Free Samples](#)

AN439, AN 439, APP439, Appnote439, Appnote 439

Copyright © by Maxim Integrated Products

Additional legal notices: <http://www.maxim-ic.com/legal>