

APPLICATION NOTE 436

# Extending Soft-Start

*Abstract: Design note shows how to extend a soft-start period. Four external components extend the soft-start of a step-up controller. The MAX668 controller, MAX1856 power supply, and MAX4130 op amps are featured.*

Additional information:

- [Technical support: power](#)

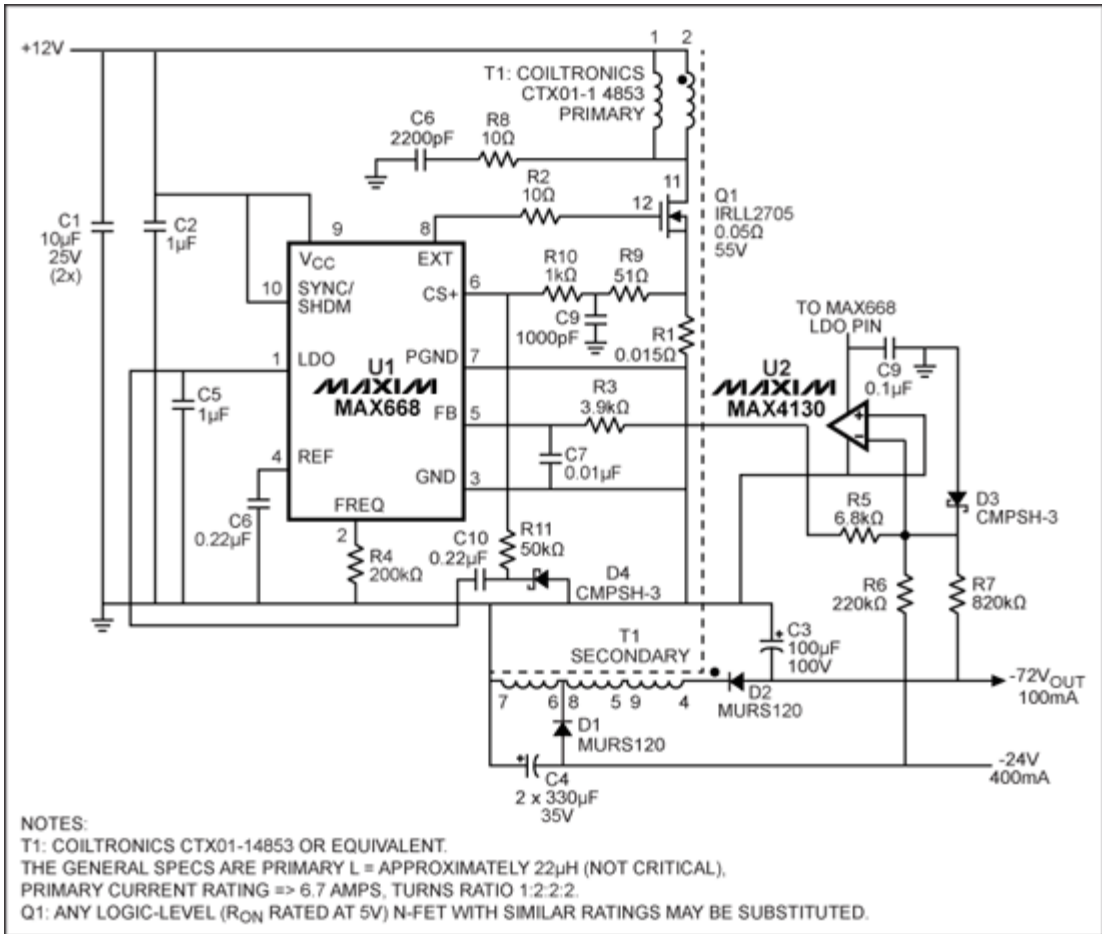

*This circuit uses the MAX668 and a transformer (which will need about a 1:2:2:2 turns ratio) to make a flyback converter. The op amp inverts the feedback from both negative output voltages.*

In systems where cards are hot-plugged, it is desirable sometimes to extend the soft-start period beyond the time provided in the IC in order to control the surge current at turn-on. The circuit above uses four external components to extend the soft-start period of the MAX668 (the technique also applies to the MAX1856 inverting transformer flyback controller).

C5 is a bypass capacitor for LDO and part of the standard circuit. R1 is the current-sense resistor. R9 and C9 filter the switching noise from the current-sense signal. In normal operation, the LDO output is 5V. The switching frequency is set to 250kHz, and the internal soft-start is 1024 clock cycles, or 4ms.

R10 and R11 are added to force the current-sense input, CS+, into current limit (+100mV). C10 is the timing capacitor that works with R10 to decrease the extra voltage applied to CS+ over a period of time. As the extra voltage decreases, the allowed current limit increases. Therefore, in this example, the current limit is increased from zero to 90% of full scale over a 33ms period (3 x R10

x C10). The soft-start period is modified by changing C10. When power is removed, D4 resets the voltage on C10.

---

#### Related Parts

[MAX1856](#) Wide-Input-Range, Synchronizable, PWM SLIC Power Supply -- [Free Samples](#)

[MAX4130](#) Single/Dual/Quad, Wide-Bandwidth, Low-Power, Single-Supply Rail-to-Rail I/O Op Amps -- [Free Samples](#)

[MAX668](#) 1.8V to 28V Input, PWM Step-Up Controllers in  $\mu$ MAX -- [Free Samples](#)

---

#### Automatic Updates

Would you like to be automatically notified when new application notes are published in your areas of interest? [Sign up for EE-Mail™](#).

---

Application note 436: [www.maxim-ic.com/an436](http://www.maxim-ic.com/an436)

More information

For technical support: [www.maxim-ic.com/support](http://www.maxim-ic.com/support)

For samples: [www.maxim-ic.com/samples](http://www.maxim-ic.com/samples)

Other questions and comments: [www.maxim-ic.com/contact](http://www.maxim-ic.com/contact)

---

AN436, AN 436, APP436, Appnote436, Appnote 436

Copyright © by Maxim Integrated Products

Additional legal notices: [www.maxim-ic.com/legal](http://www.maxim-ic.com/legal)